

## Power amplifier, GPA-4.5-7.5-41.5

### Parameters

- Operating frequency: 4.5~7.5GHz
- Psat: 41.5dBm
- Power gain: 20dB@Pin=22dBm
- Power supply: 28V/-2.7V
- 50ohm input/output
- Chip size: 2.40mm×1.70mm×0.1mm



### Product introduction

GPA-5-7-41 is a power amplifier chip manufactured using GaN HEMT technology. The working frequency band covers 4.5~7.5 GHz, and under a supply voltage of 28V, it can provide a power gain of 20dB, with a saturated output power greater than 42dBm. The chip is grounded through the back through-hole, mainly used in communication systems, high-power transceiver components, and other fields.

### Bare die block diagram

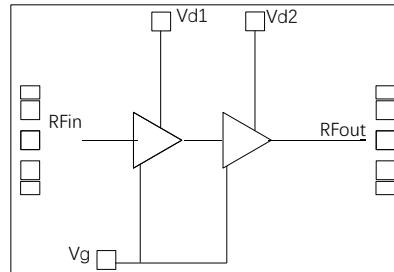

### Max. operating conditions<sup>[1]</sup>

| Parameter             | Ratings      |
|-----------------------|--------------|
| Drain voltage         | +30V         |
| Input power           | 30dBm        |
| Operating temperature | -55°C~+85°C  |
| Storage temperature   | -65°C~+120°C |

[1] Exceeding any of these limits may cause permanent damage.

### DC electrical specifications (TA=+25 °C)

| Parameter               | Min | Typ  | Max | Unit |
|-------------------------|-----|------|-----|------|
| Gate bias voltage       |     | -2.7 |     | V    |
| Drain working voltage   |     | 28   |     | V    |
| Quiescent drain current |     | 0.55 |     | A    |
| Dynamic drain current   |     | 1.2  |     | A    |

**Microwave electrical specifications (TA=+25 °C, Vd=+28V, Vg=-2.7V, CW)**

| Parameter                  | Min     | Typ                           | Max | Unit |
|----------------------------|---------|-------------------------------|-----|------|
| Frequency range            | 5.0~7.0 |                               |     | GHz  |
| Psat                       |         | 41.5                          |     | dBm  |
| PAE                        |         | 47@5GHz<br>60@6GHz<br>54@7GHz |     | %    |
| Power gain<br>(@Pin=20dBm) |         | 20                            |     | dB   |
| Power gain flatness        |         | ± 0.4                         |     | dB   |
| Input/output return loss   |         | -11/-16                       |     | dB   |

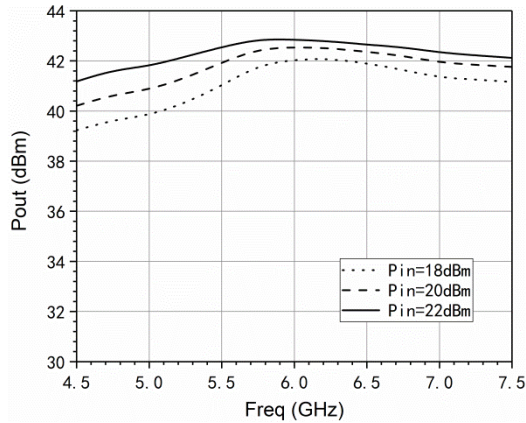
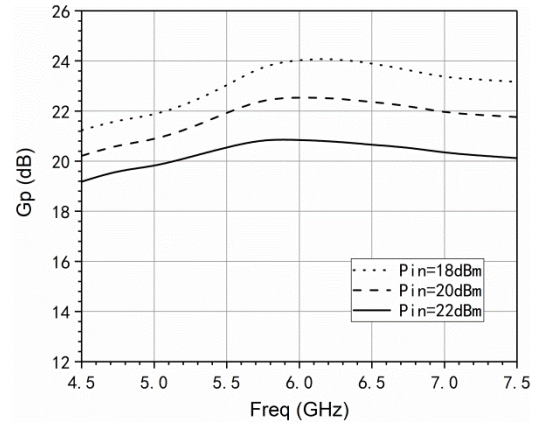
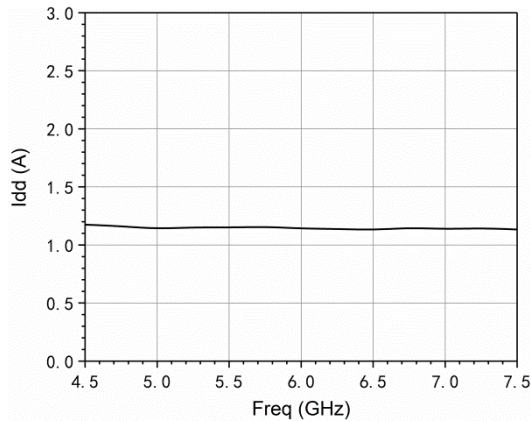
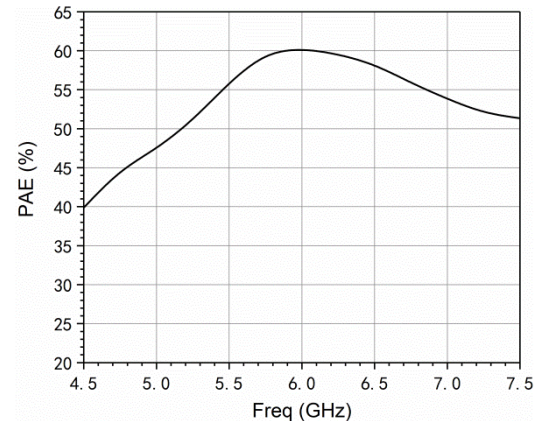
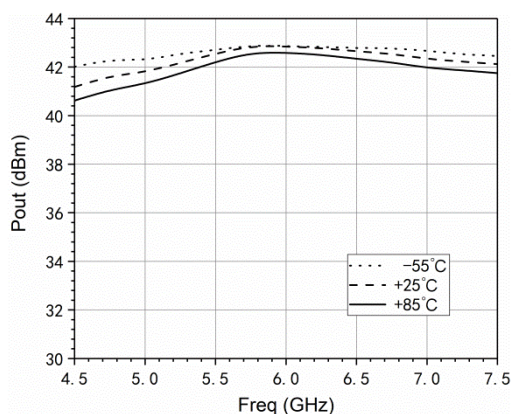
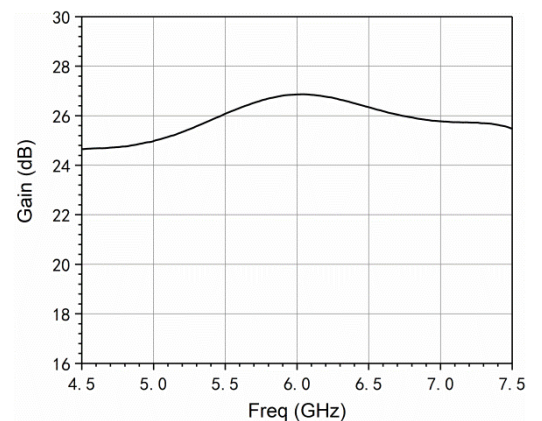
**Typical test results (TA=+25°C, Vd=+28V, Vg=-2.7V, CW)**
**Output power VS. Frequency**

**Power gain VS. Frequency**

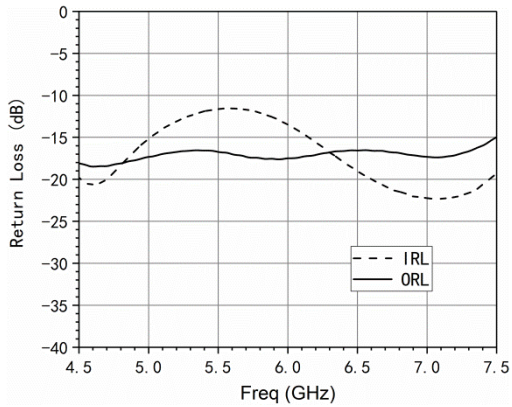
**Dynamic current VS. Frequency (@Pin=22dBm)**

**PAE VS. Frequency (@Pin=22dBm)**

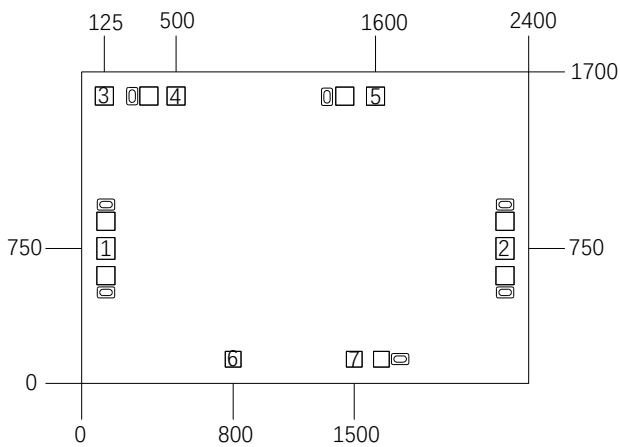
**Output power VS. Frequency (@Pin=22dBm)**

**Small signal gain VS. Frequency (@Pin=-25dBm)**

### Input/output return loss VS. Frequency



### IC outline dimensions



**Notes:**

1. Unit:  $\mu\text{m}$
2. Gold plating on bonding pads
3. Dimensional tolerance:  $\pm 20\mu\text{m}$

### Pad Definition

| Pad Number | Function | Description  | Dimensions            |
|------------|----------|--|-----------------------|
| 1          | IN       | RF input, external 50 ohm system, no need for external blocking capacitor  | 100×120 $\mu\text{m}$ |
| 2          | OUT      | RF output, external 50 ohm system, no need for external blocking capacitor | 100×120 $\mu\text{m}$ |
| 4、5、7      | Vd       | Drain power supply   | 100×100 $\mu\text{m}$ |
| 3、6        | Vg       | Gate power supply  | 100×100 $\mu\text{m}$ |

**QFN Bottom view diagram**

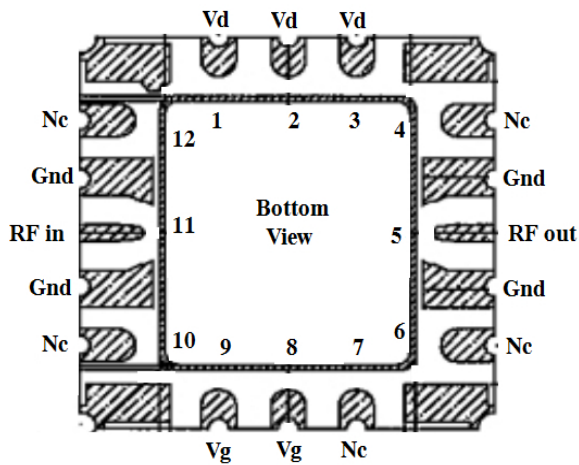

**Application schematic diagram**

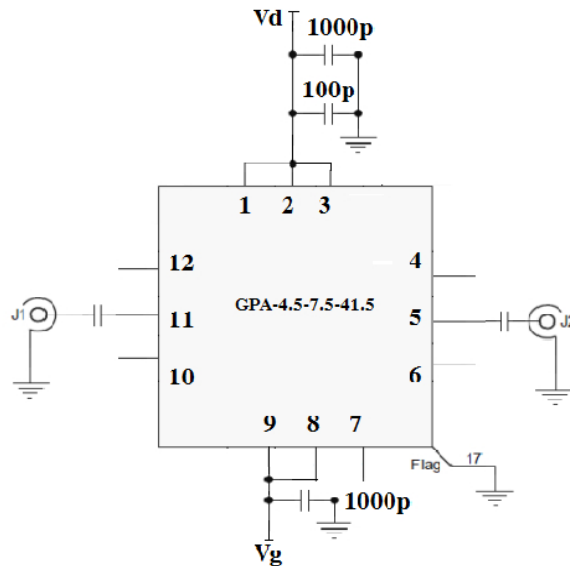

Note: To ensure more stable performance of the amplifier, it is recommended to weld ceramic capacitors with the recommended capacitance values in the above assembly diagram at the feeding end for filtering. The number of filtering capacitors can also be increased or different capacitance values can be combined according to actual needs.

**Note:**

1. Please assemble and use in a purified environment, store in anti-static containers, and keep dry
2. The back of the chip is grounded with gold backing. Please ensure that the back is in full contact with the ground and well grounded during use
3. Use gold tin solder with a ratio of 80/20 to sinter, with a sintering temperature not exceeding 300 °C and a sintering time as short as possible, not exceeding 20 seconds
4. This product is an electrostatic sensitive device. Please pay attention to anti-static measures during storage and use
5. Do not attempt to clean the surface of the chip using dry or wet chemical methods
6. If you have any questions, please contact the supplier

