

Performance characteristics

- Operating frequency: 0.8~18GHz
- Gain: 25dB
- NF:3dB
- P-1dB: 14dBm
- Quiescent current: 90mA
- Outline Dimensions: 10x8x2.5mm

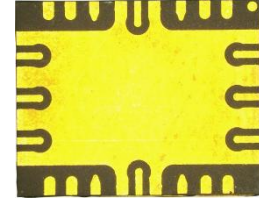

Principle diagram

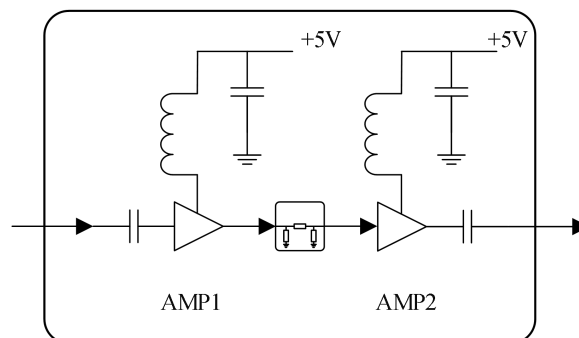

Product introduction

GF028018Q1 low noise amplifier chip adopts GaAs technology, with a frequency range of 0.8-18GHz, a small signal gain of 25dB, an in band noise figure of 3dB, a +5V power supply, and it is housed in a ceramic package, suitable for SMT.

Absolute maximum ratings	
Parameter	Ratings
VDD	+7V
Input power	+20dBm
Operating temperature	-55~+85° C
Storage temperature	-55~+150° C
Note: Exceeding any of these limits may cause permanent damage.	

Electrical parameters(TA = +25°C, 50Ω system)

Parameter	Min	Typ	Max	Unit
Operating frequency	0.8		18	GHz
gain		25		dB
Gain flatness		±1.5		dB
Noise coefficient		3		dB
input return loss		-11		bit
Output Return Loss		-11		dB
P-1dB		14		dB
Quiescent current		90		dB

Main indicator testing curve

Gain VS. Frequency

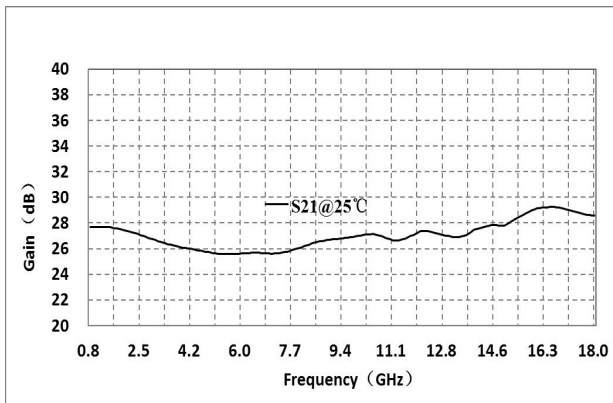

Noise figure VS. Frequency

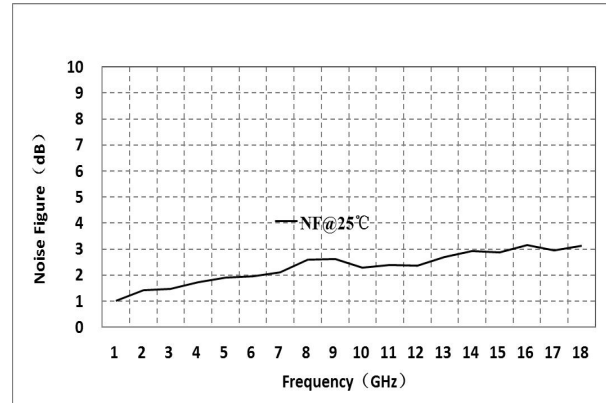

Input return loss VS. Frequency

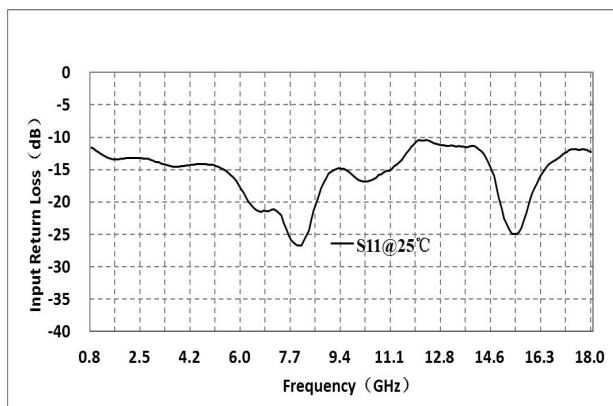

Output return loss VS. Frequency

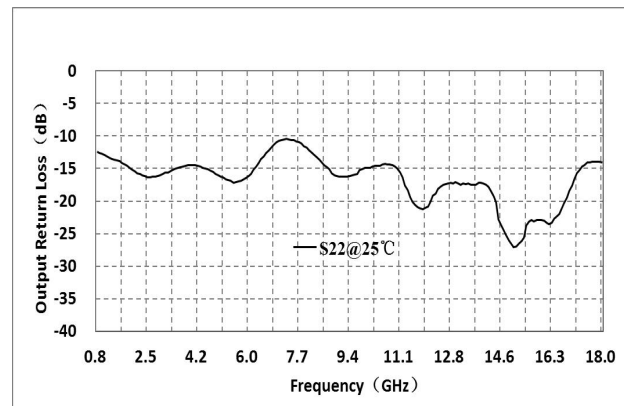

P-1 VS. Frequency

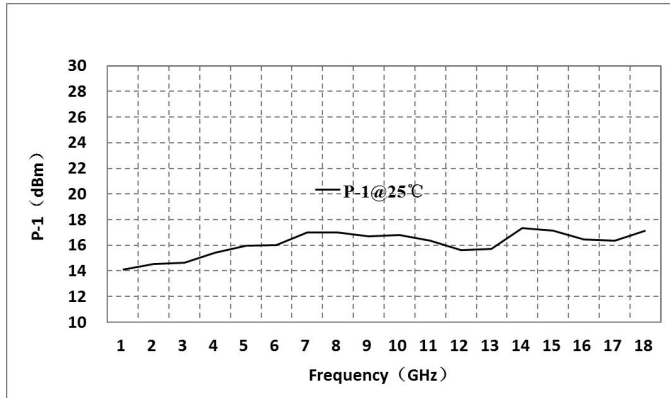

Reverse isolation VS. Frequency

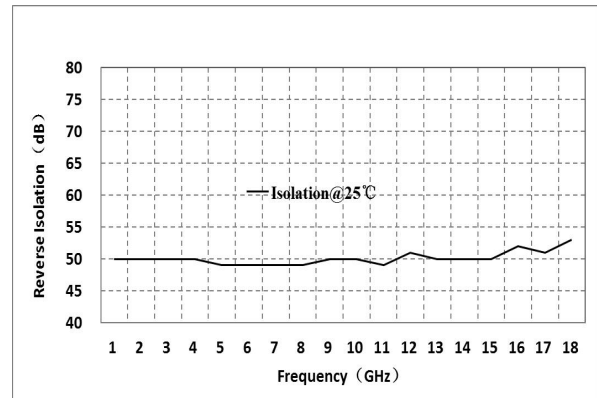

External structure

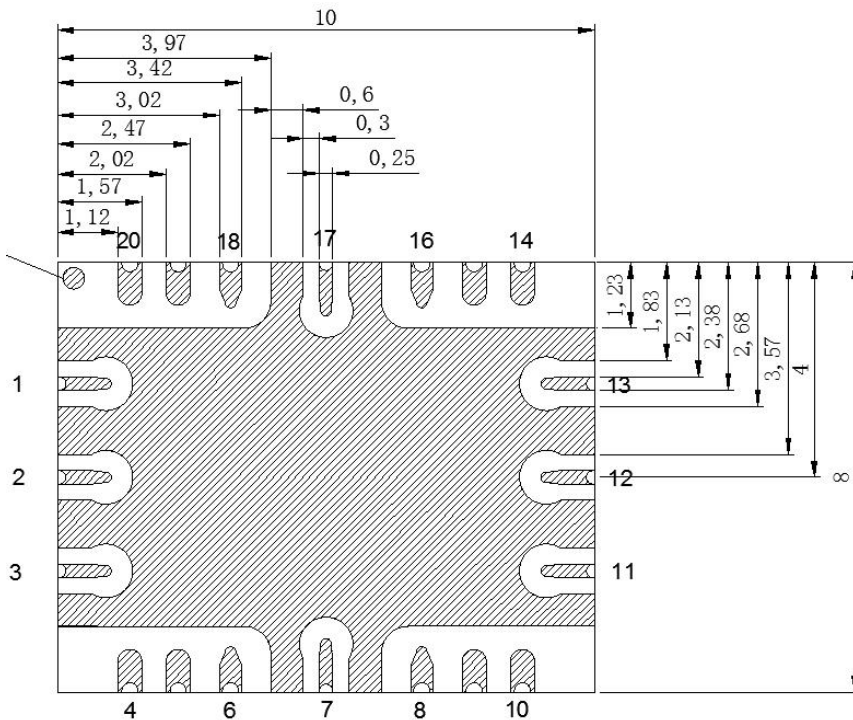

Pin	Function	Description
1、13	+5V	+5V power supply
2	RFin	RF input, no need for blocking capacitors
3~11	GND	Ground
12	RFout	RF output, no need for blocking capacitors
14~20	GND	Ground

Note:

- Unit: mm;
- The device should be stored in a dry and nitrogen environment. When the device cannot be used up after being unpacked, it should be immediately stored in a drying oven or vacuum sealed to avoid absorbing moisture from the air;
- Devices are sensitive to static electricity, and attention should be paid to anti-static measures during storage, transportation, assembly, and use;
- Please connect all grounding pins to RF ground;
- This product is suitable for reflow soldering installation process, with a maximum reflow soldering peak temperature of 260 °C.