

Performance characteristics

- Operating frequency: 1~18GHz
- Gain: 25dB
- NF: 2.7dB
- P-1dB: 13dBm
- Quiescent current: 90mA
- Outline Dimensions: 10x8x2.5mm

Principle diagram

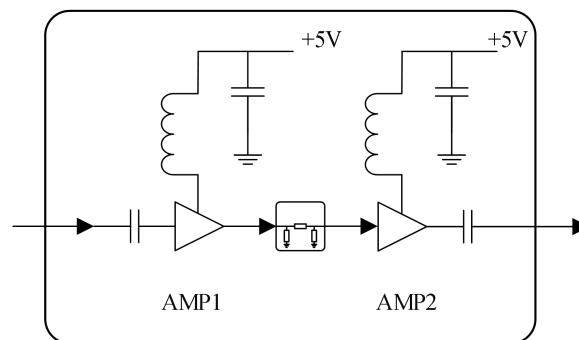

Product introduction

GF020118Q1 low noise amplifier chip adopts GaAs technology, with a frequency range of 1-18GHz, a small signal gain of 25dB, an in band noise figure of 2.7dB, a +5V power supply, and it is housed in a ceramic package, suitable for SMT.

Absolute maximum ratings	
Parameter	Ratings
VDD	+7V
Input power	+20dBm
Operating temperature	-55~+85° C
Storage temperature	-55~+150° C
Note: Exceeding any of these limits may cause permanent damage.	

Electrical parameters(TA = +25°C, 50Ω system)

Parameter	Min	Typ	Max	Unit
Operating frequency	1		18	GHz
gain		25		dB
Gain flatness		±1		dB
Noise coefficient		2.7		dB
input return loss		-12		bit
Output Return Loss		-13		dB
P-1dB		13		dB
Quiescent current		90		dB

Main indicator testing curve

Gain VS. Frequency

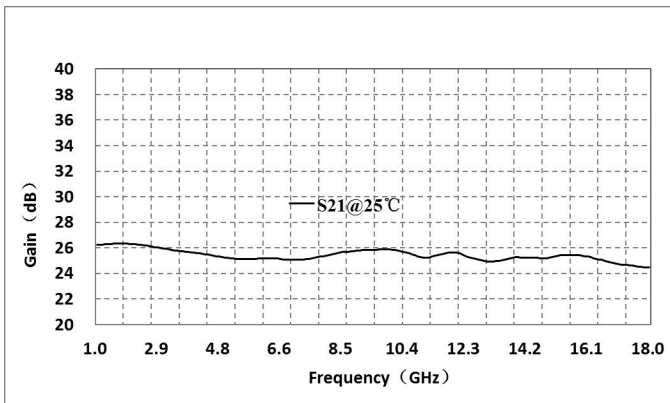

Noise figure VS. Frequency

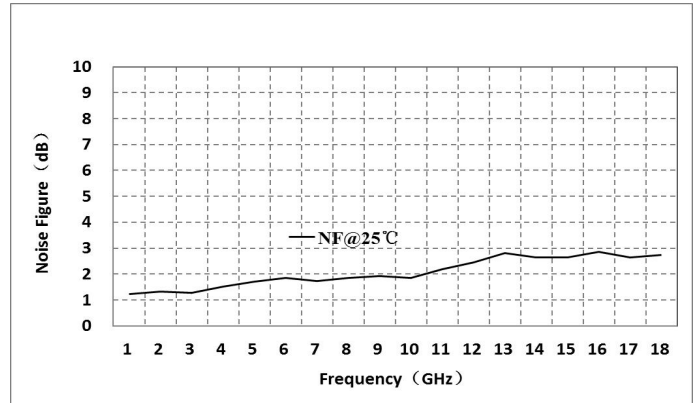

Input return loss VS. Frequency

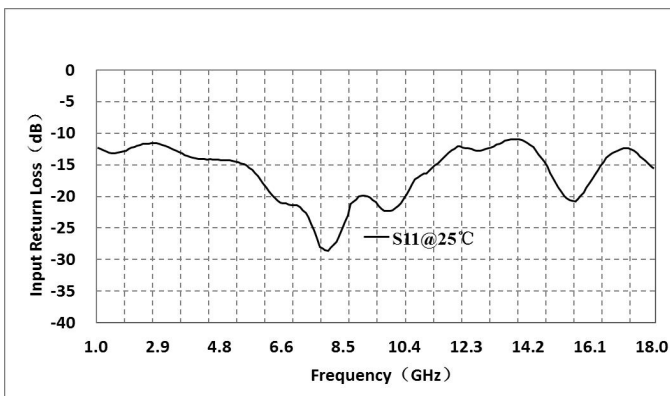

Output return loss VS. Frequency

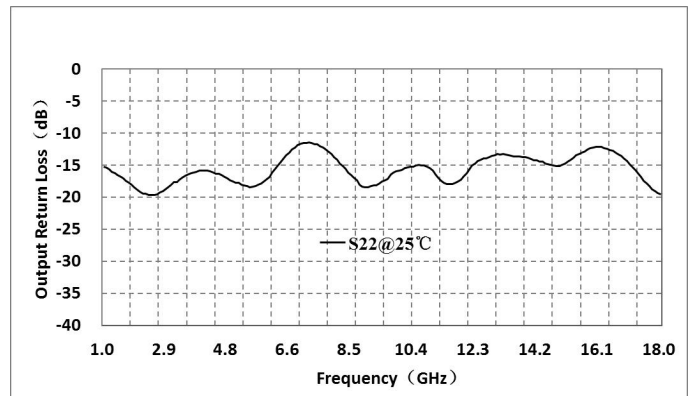

Low noise amplifier chip, 1~18GHz

P-1 VS. Frequency

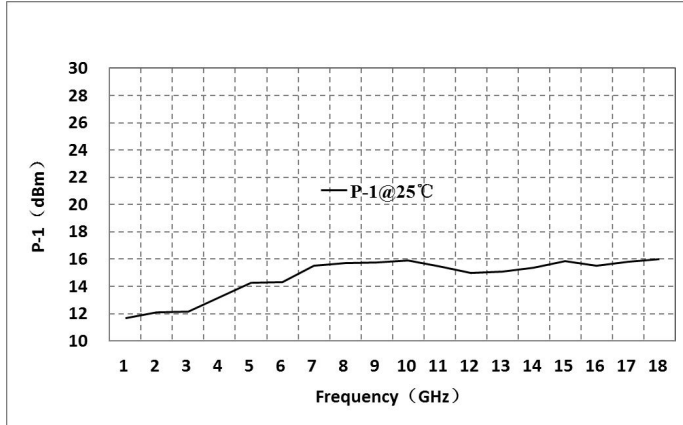

Reverse isolation VS. Frequency

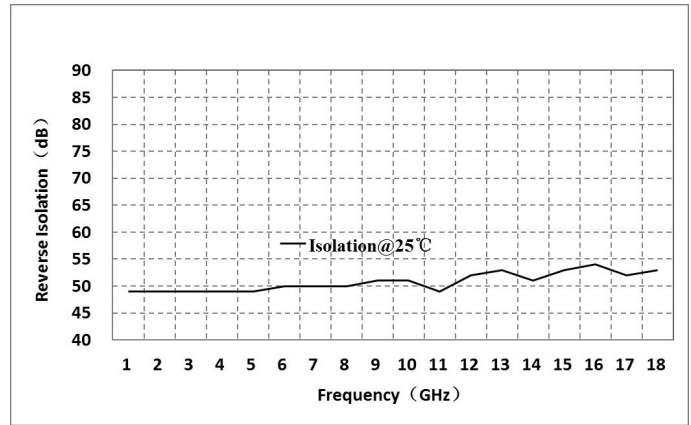

External structure

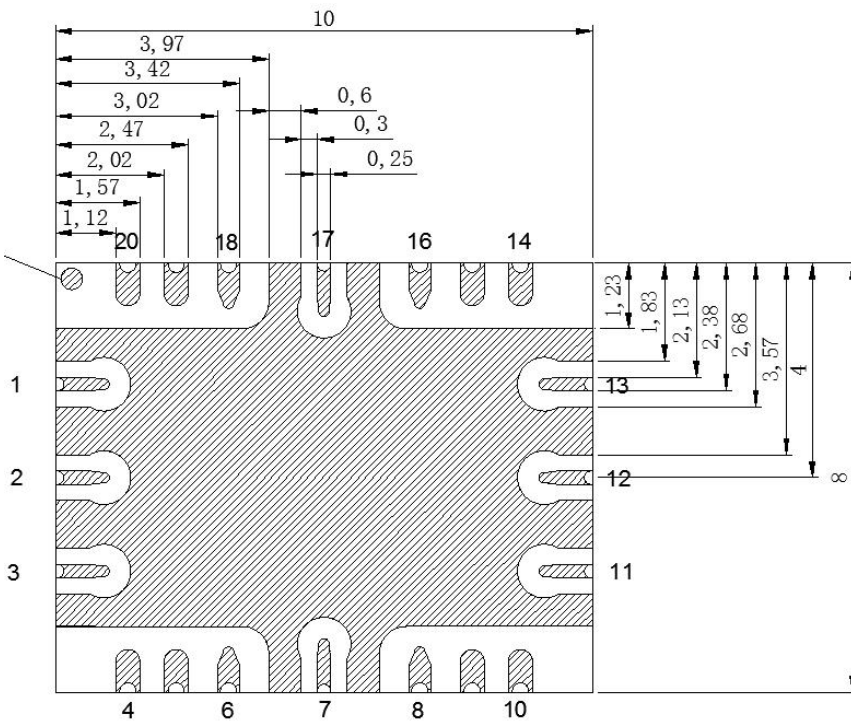

Pin	Function	Description
1、 13	+5V	+5V power supply
2	RFin	RF input, no need for blocking capacitors
3~11	GND	Ground
12	RFout	RF output, no need for blocking capacitors
14~20	GND	Ground

Note:

- Unit: mm;
- The device should be stored in a dry and nitrogen environment. When the device cannot be used up after being unpacked, it should be immediately stored in a drying oven or vacuum sealed to avoid absorbing moisture from the air;
- Devices are sensitive to static electricity, and attention should be paid to anti-static measures during storage, transportation, assembly, and use;
- Please connect all grounding pins to RF ground;
- This product is suitable for reflow soldering installation process, with a maximum reflow soldering peak temperature of 260 °C.