

GaN MMIC Power Amplifier Chip, 7-13 GHz

Performance characteristics

- Frequency range: 7~13GHz
- Psat: 39dBm
- Power gain: 18dB@Pin=21dBm
- Power supply: 28V/-2.7V
- 50ohm input/output
- Chip size: 2.80mm×1.65mm×0.1mm

Block Diagram

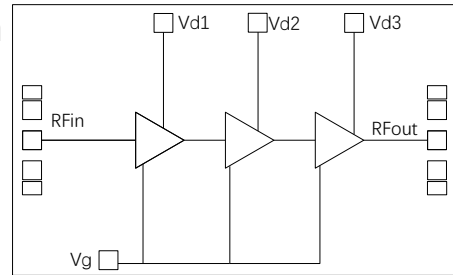

Product Introduction

GPA7-13-39 is a power amplifier chip manufactured using GaN HEMT technology. The working frequency band covers 7.0-13.0GHz, and under a supply voltage of 28V, it can provide 18dB power gain with a saturated output power greater than 39dBm. The chip is grounded through the back through-hole. Mainly used in communication systems, high-power transceiver components, and other fields.

DC electrical parameters (T_A=+25°C)

Parameter	Min	Typ	Max	Unit
Gate bias voltage		-2.7		V
Drain working voltage		28		V
Quiescent drain current		0.42		A
Dynamic drain current		1.2		A

Microwave electrical parameters (T_A=+25°C, Vd=+28V, Vg=-2.7V, CW)

Parameter	Min	Typ	Max	Unit
Frequency range	5.0~7.0			GHz
Psat	39	40	41	dBm
PAE	32	35	43	%
Power gain (@Pin=21dBm)	18	19	20	dB
Power gain flatness		±1		dB
Input/output return loss		-12/-7		dB

Absolute maximum ratings^[1]

Parameter	Ratings
Drain voltage	+30V
Input power	30dBm
Operating temperature	-55°C~+85°C
Storage temperature	-65°C~+120°C

[1] Exceeding any of these limits may cause permanent damage.

GaN MMIC Power Amplifier Chip, 7-13 GHz

Typical performance curves ($T_A=+25^\circ\text{C}$, $V_d: +28\text{V}$, $V_g=-2.7\text{V}$, CW)

Output power vs. frequency

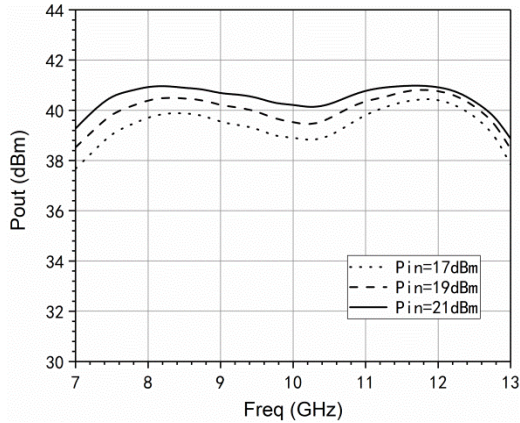

Power gain vs. frequency

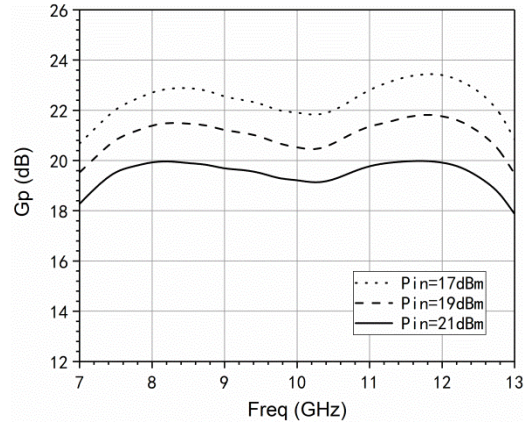

Dynamic current vs. frequency(@Pin=21dBm)

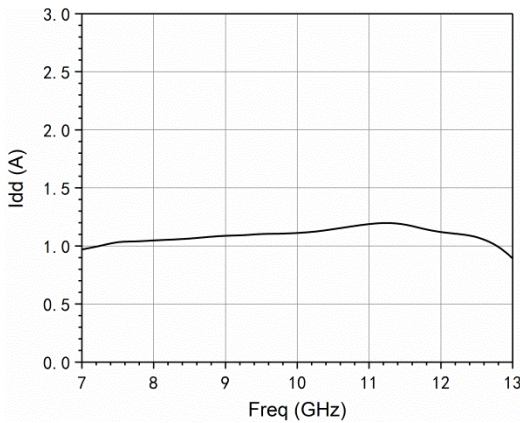

Power added efficiency vs. frequency(@Pin=21dBm)

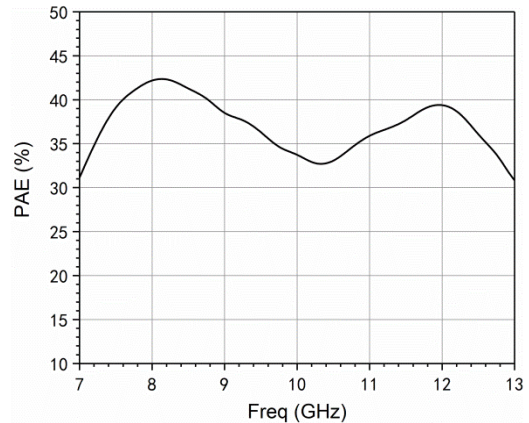

Three temperature output power vs. frequency (@Pin=21dBm)

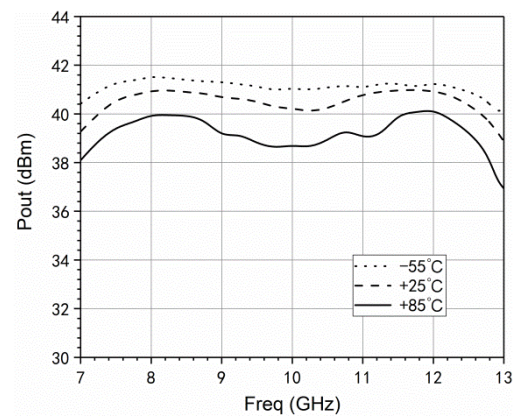

Small signal gain vs. frequency (@Pin=-10dBm)

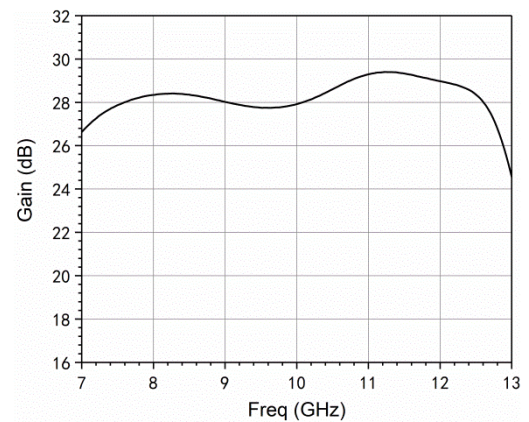

GaN MMIC Power Amplifier Chip, 7-13 GHz

Input/output return loss vs. frequency

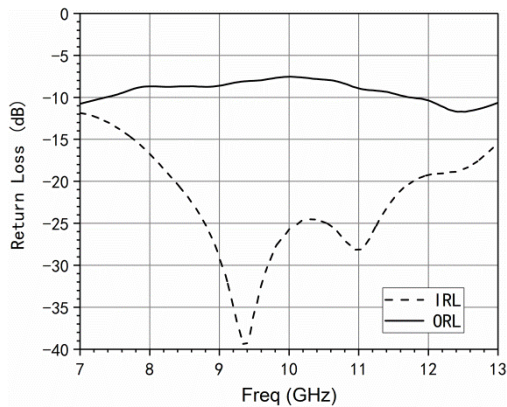

Outline Dimensions

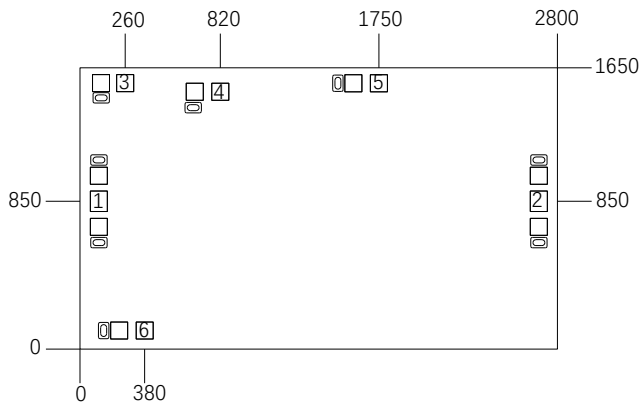

Notes:

1. Unit: μm
2. Gold plating on bonding pads
3. Dimensional tolerance: $\pm 20 \mu\text{m}$

Pad Definition

Pad Number	Function	Description	Dimensions
1	IN	RF input, external 50 ohm system, no need for external blocking capacitor	100×120μm
2	OUT	RF output, external 50 ohm system, no need for external blocking capacitor	100×120μm
4、5、7	Vd	Drain power supply	100×100μm
3、6	Vg	Gate power supply	100×100μm

GaN MMIC Power Amplifier Chip, 7-13 GHz

Suggested assembly diagram

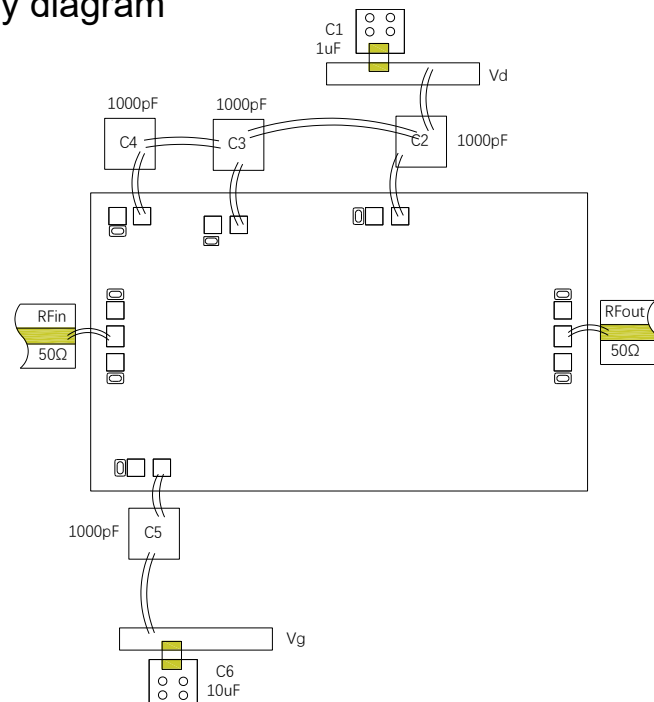

Note: To ensure more stable performance of the amplifier, it is recommended to weld ceramic capacitors with the recommended capacitance values in the above assembly diagram at the feeding end for filtering. The number of filtering capacitors can also be increased or different capacitance values can be combined according to actual needs.

Note:

1. Please assemble and use in a purified environment, store in anti-static containers, and keep dry
2. The back of the chip is grounded with gold backing. Please ensure that the back is in full contact with the ground and well grounded during use
3. Use gold tin solder with a ratio of 80/20 to sinter, with a sintering temperature not exceeding 300 °C and a sintering time as short as possible, not exceeding 20 seconds
4. This product is an electrostatic sensitive device. Please pay attention to anti-static measures during storage and use
5. Do not attempt to clean the surface of the chip using dry or wet chemical methods
6. If you have any questions, please contact the supplier

