

GaN MMIC Power Amplifier Chip, 5.0-7.0 GHz

Performance characteristics

- Frequency range: 5.0~7.0GHz
- Psat: 40.5dBm
- Saturated power gain: 17dB
- Power supply: 28V/190mA
- 50ohm input/output
- Chip size: 2.4mm×1.6mm×0.1mm

Block Diagram

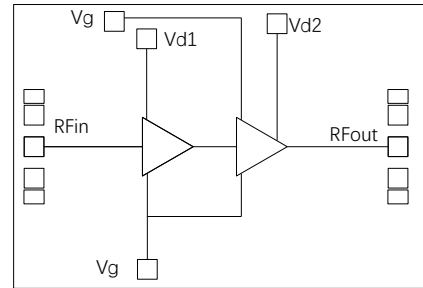

Product Introduction

GPA5-7-40 is a power amplifier chip manufactured using GaN HEMT technology. Continuous wave working mode, covering a frequency band of 5.0~7.0 GHz, can provide a saturation power gain of 17dB at a supply voltage of 28V, with a saturation output power of 40.5 dBm. The chip is grounded through the back through-hole. Mainly used in communication systems, high-power transceiver components, and other fields.

DC electrical parameters ($T_A=+25^\circ\text{C}$)

Parameter	Min	Typ	Max	Unit
Gate bias voltage		-2.2		V
Drain working voltage		28		V
Quiescent drain current		190		mA
Dynamic drain current		1000		mA

Microwave electrical parameters ($T_A=+25^\circ\text{C}$, $V_d=+28\text{V}$, continuous wave)

Parameter	Min	Typ	Max	Unit
Frequency range	5.0~7.0			GHz
Psat	40.3	40.5	41	dBm
PAE		44		%
Power gain		17		dB
Power gain flatness		± 0.2		dB
Input/output return loss		-10		dB

Absolute maximum ratings^[1]

Parameter	Ratings
Drain voltage	+30V
Input power	+30dBm
Operating temperature	-55°C~+85°C
Storage temperature	-65°C~+120°C

[1] Exceeding any of these limits may cause permanent damage.

GaN MMIC Power Amplifier Chip, 5.0-7.0 GHz

Typical performance curves (Vd: +28V, quiescent Id=190mA, continuous wave)

Gain vs. frequency (@Pin=-25dBm)

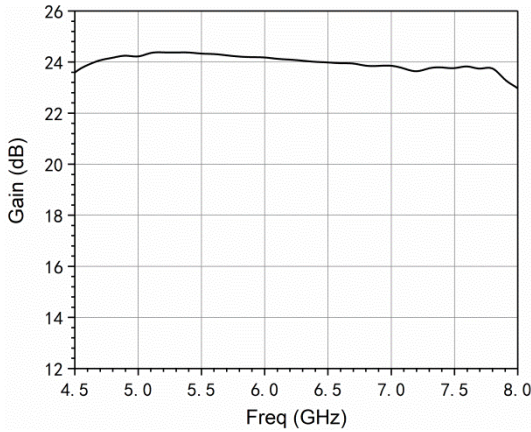

Power gain vs. frequency

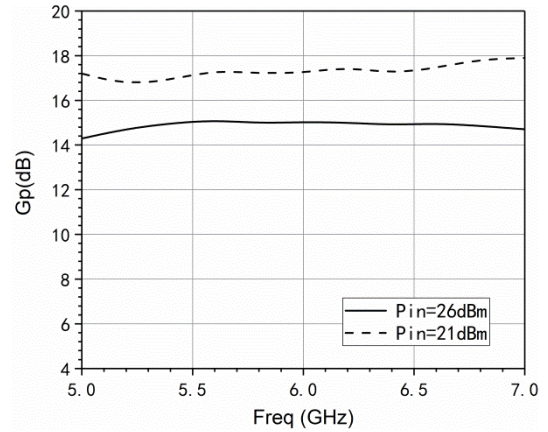

Output power vs. frequency

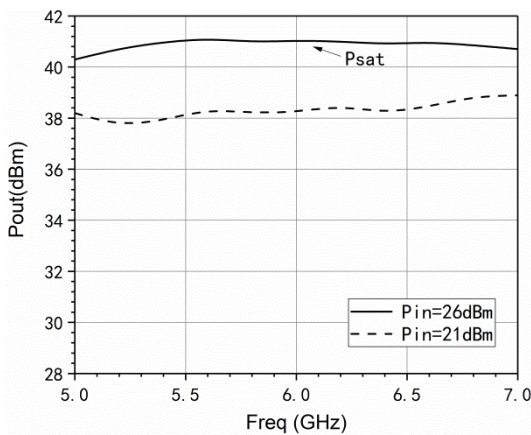

PAE vs. frequency (@ Pin=26dBm)

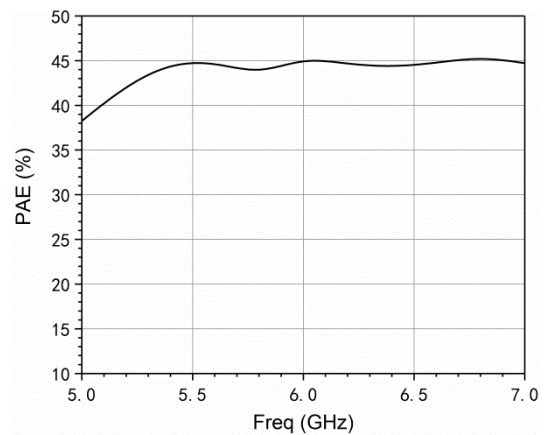

Input return loss vs. frequency

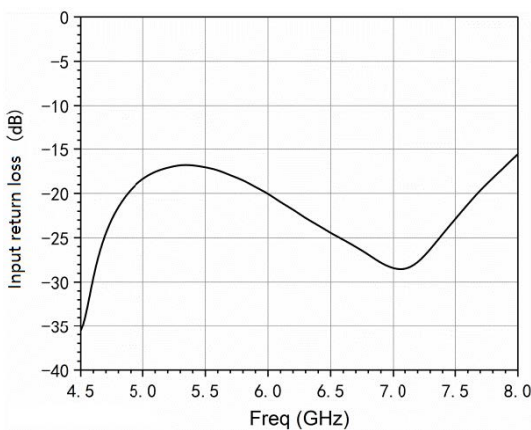

Output return loss vs. frequency

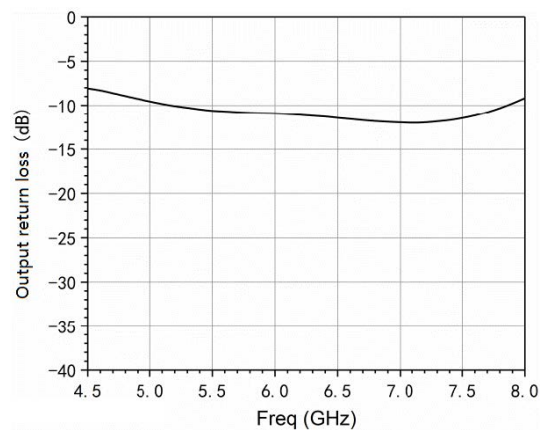

GaN MMIC Power Amplifier Chip, 5.0-7.0 GHz

Idd VS. frequency

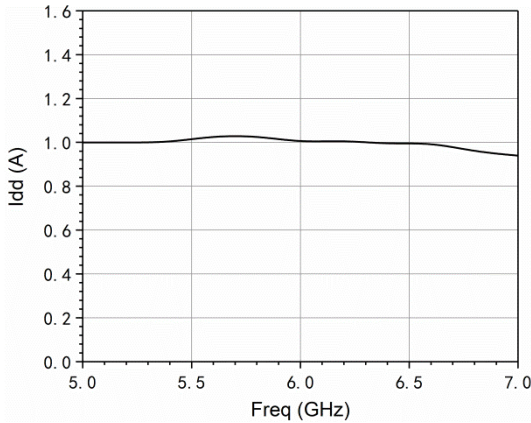

Reverse isolation vs. frequency (@Psat)

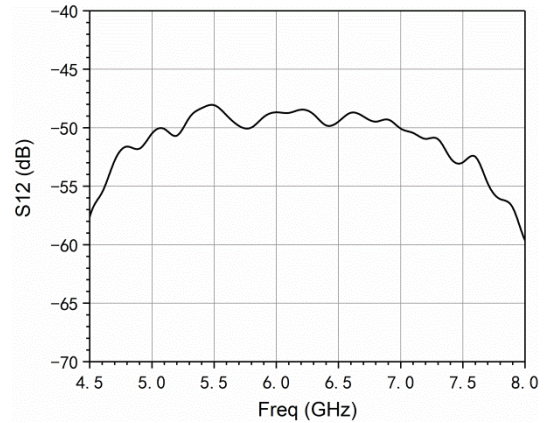

Outline Dimensions

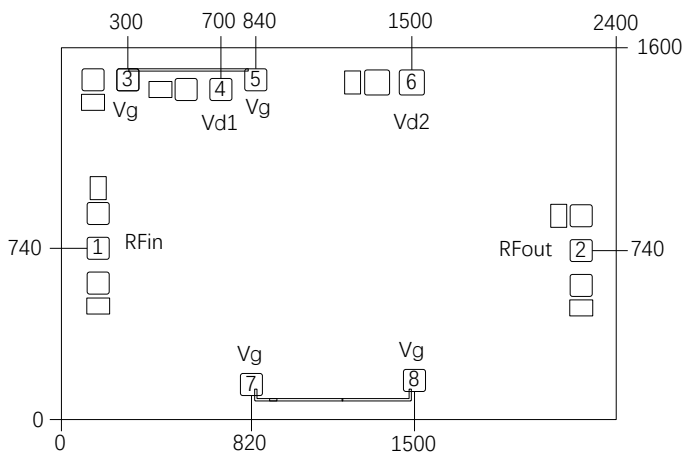

Notes:

1. Unit: μm
2. Gold plating on bonding pads
3. Dimensional tolerance: $\pm 20 \mu\text{m}$

Pad Definition

Pad Number	Function	Description	Dimensions
1	IN	RF input terminal, external 50 ohm system, no need for external blocking capacitor	100 × 100 μm
2	OUT	RF output terminal, external 50 ohm system, no need for external blocking capacitor	100 × 100 μm
4, 6	Vd	Drain power supply, 28V	100 × 100 μm
3, 5, 7, 8	Vg	Gate power supply terminal, -2.2V, quiescent curren 180-200mA	100 × 100 μm

GaN MMIC Power Amplifier Chip, 5.0-7.0 GHz

Suggested assembly diagram

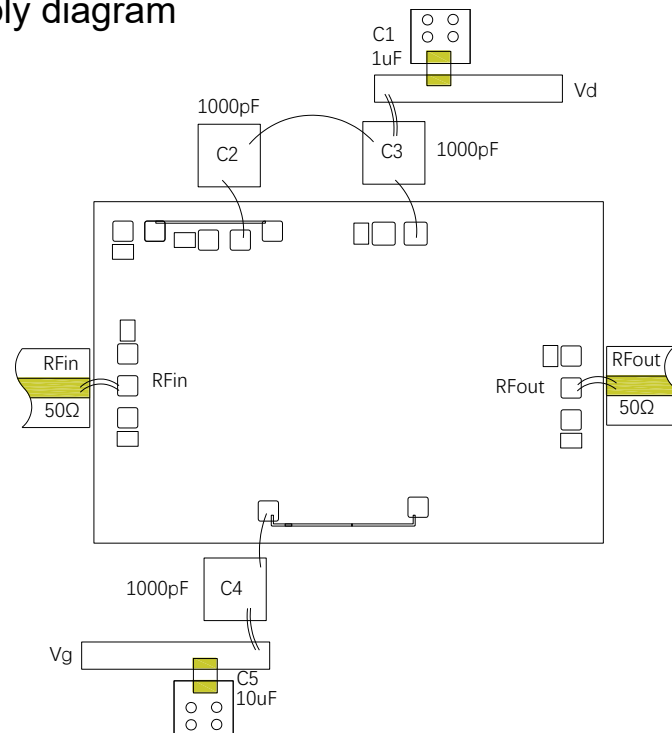

Note: To ensure more stable performance of the amplifier, it is recommended to weld ceramic capacitors with the recommended capacitance values in the above assembly diagram at the feeding end for filtering. The number of filtering capacitors can also be increased or different capacitance values can be combined according to actual needs.

Note:

1. Please assemble and use in a purified environment, store in anti-static containers, and keep dry
2. The back of the chip is grounded with gold backing. Please ensure that the back is in full contact with the ground and well grounded during use
3. Use gold tin solder with a ratio of 80/20 to sinter, with a sintering temperature not exceeding 300 °C and a sintering time as short as possible, not exceeding 20 seconds
4. This product is an electrostatic sensitive device. Please pay attention to anti-static measures during storage and use
5. Do not attempt to clean the surface of the chip using dry or wet chemical methods
6. If you have any questions, please contact the supplier

