

Performance characteristics **GaN MMIC Power Amplifier Chip, 2.7-3.5GHz**

- Frequency range: 2.7~3.5GHz
- Psat: 46dBm
- Power gain: 26dB
- Power supply: 28V/900mA
- 50ohm input/output
- Chip size 3.5mm×2.5mm×0.1mm

Block Diagram

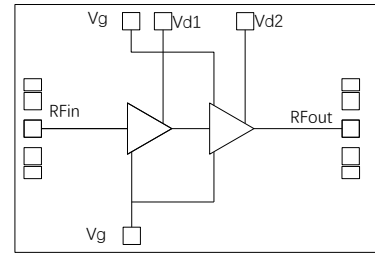

Product Introduction

GPA2.7-3.5-46 is a power amplifier chip manufactured using GaN HEMT technology. The working frequency band covers 2.7-3.5GHz, and under a supply voltage of 28V, it can provide a power gain of 26dB, with a saturated output power of 46dBm. The chip is grounded through the back through-hole. Mainly used in communication systems, high-power transceiver components, and other fields.

DC electrical parameters (T_A=+25°C)

Parameter	Min	Typ	Max	Unit
Gate bias voltage		-2.25		V
Drain working voltage		28		V
Quiescent drain current		900		mA
Dynamic drain current		3500		mA

Microwave electrical parameters (T_A=+25°C, V_d=+28V, Pulse width 300us, duty cycle 30%)

Parameter	Min	Typ	Max	Unit
Frequency range		2.7~3.5		GHz
Psat		46		dBm
PAE		53		%
Power gain		26		dB
Power gain flatness		±0.2		dB
Input/output return loss		-10		dB

Absolute maximum ratings^[1]

Parameter	Ratings
Drain voltage	+30V
Input power	+30dBm
Operating temperature	-55°C~+85°C
Storage temperature	-65°C~+120°C

[1] Exceeding any of these limits may cause permanent damage.

GaN MMIC Power Amplifier Chip, 2.7-3.5GHz

Typical performance curves (Vd: +28V, quiescent Id=900mA, Pulse width 300us, duty cycle 30%)

Gain vs. frequency (@Pin=-25dBm)

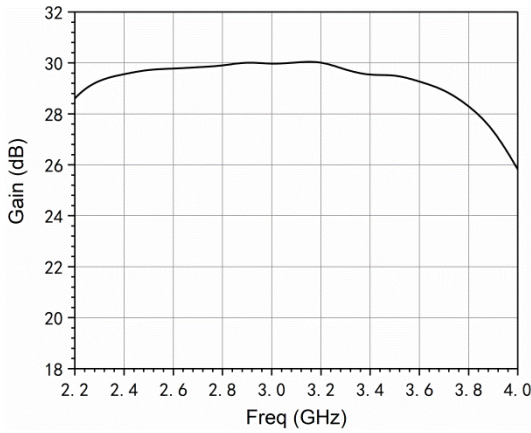

Power gain vs. frequency

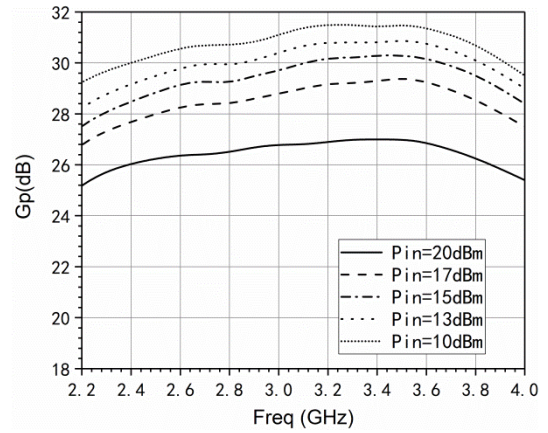

Saturated power vs. frequency

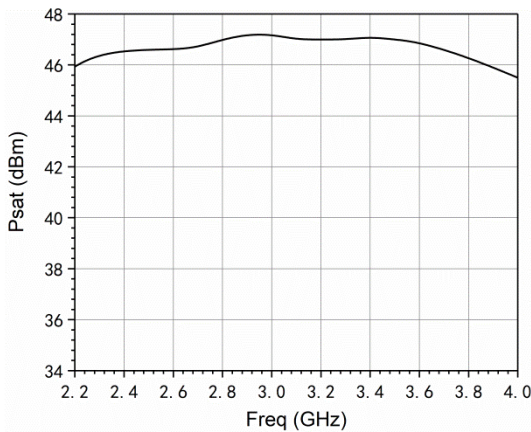

Output power vs. frequency

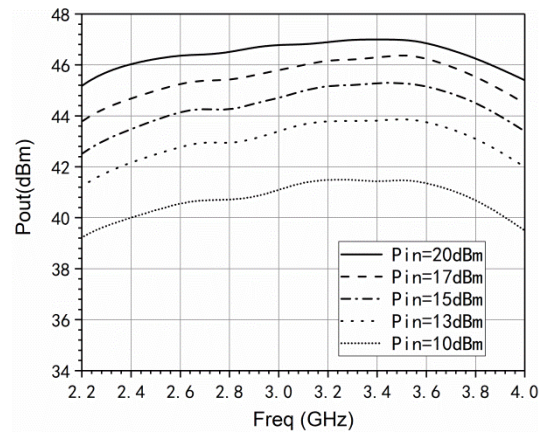

PAE vs. frequency

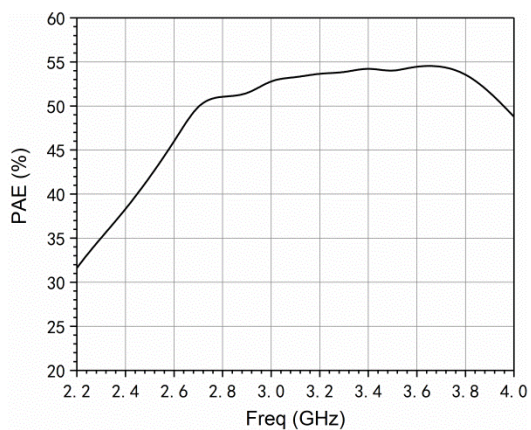

Return loss vs. frequency

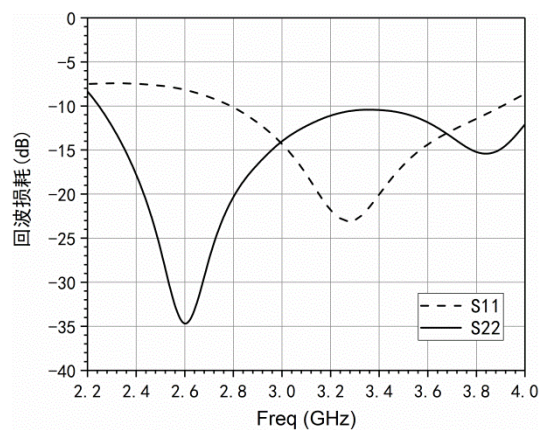

GaN MMIC Power Amplifier Chip, 2.7-3.5GHz

I_{dd} VS. frequency

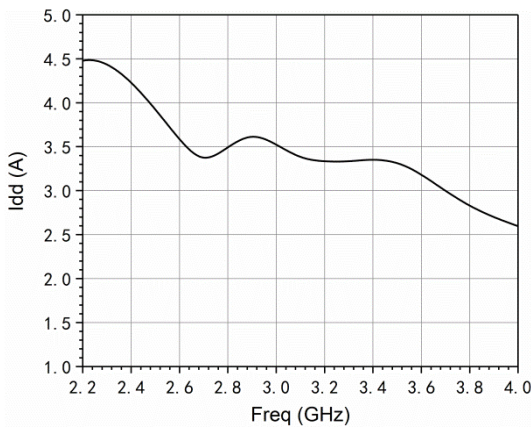

Reverse isolation vs. frequency (@P_{sat})

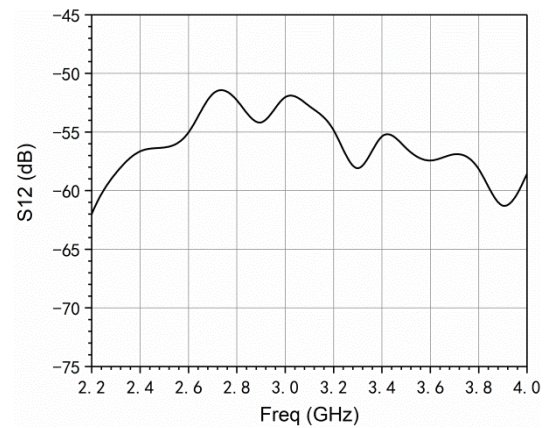

Outline Dimensions

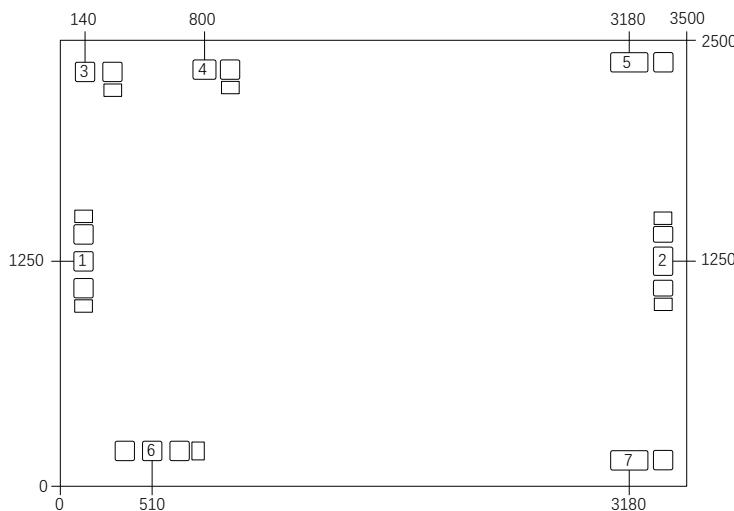

Notes:

1. Unit: μm
2. Gold plating on bonding pads
3. Dimensional tolerance: $\pm 20 \mu\text{m}$

Pad Definition

Pad Number	Function	Description	Dimensions
1	IN	RF input, external 50 ohm system, no need for external blocking capacitor	100×100 μm
2	OUT	RF output, external 50 ohm system, no need for external blocking capacitor	100×100 μm
4、5、7	V _d	Drain power supply, 28V	100×100 μm
3、6	V _g	Gate power supply, -2.2~-2.3V, quiescent current 800~950mA	100×100 μm

GaN MMIC Power Amplifier Chip, 2.7-3.5GHz

Suggested assembly diagram

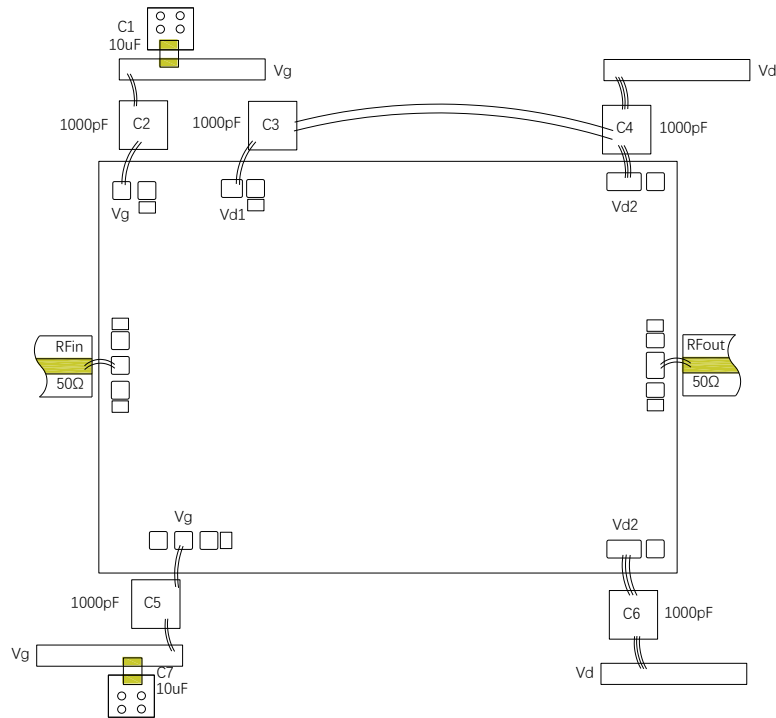

Note: To ensure more stable performance of the amplifier, it is recommended to weld ceramic capacitors with the recommended capacitance values in the above assembly diagram at the feeding end for filtering. The number of filtering capacitors can also be increased or different capacitance values can be combined according to actual needs. If the pulse works, no ceramic capacitor is added at the drain Vd.

Note:

1. Please assemble and use in a purified environment, store in anti-static containers, and keep dry
2. The back of the chip is grounded with gold backing. Please ensure that the back is in full contact with the ground and well grounded during use
3. Use gold tin solder with a ratio of 80/20 to sinter, with a sintering temperature not exceeding 300 °C and a sintering time as short as possible, not exceeding 20 seconds
4. This product is an electrostatic sensitive device. Please pay attention to anti-static measures during storage and use
5. Do not attempt to clean the surface of the chip using dry or wet chemical methods
6. If you have any questions, please contact the supplier



This product is sensitive to static electricity. Please pay attention to anti-static measures during use