

## GaAs PIN Reflective SP4T Switch Chip, 2 - 20GHz

### Performance characteristics

- Frequency Range: 2-20GHz
- Insertion loss : 0.9dB typ.
- Isolation: 59 dB typ.
- P-1dB: 27dBm @17GHz
- 50Ohm input / output
- 100% on-wafer testing
- Chip size: 2.32 x 1.77 x 0.1mm
- Silicon nitride passivation, scratch protection

### Product Introduction

GSW4B1 is a GaAs PIN reflective single-pole four-throw switch chip with 50Ω matching at the input/output end, a frequency range of 2 to 20GHz , and -5V/+5V control. It has a built-in bias network and DC blocking capacitors, which is easy to use. It has excellent switching characteristics and port standing wave characteristics in the entire operating frequency range, and is very suitable for microwave hybrid integrated circuits, multi-chip modules, and low-power systems. The switch chip uses on-chip through-hole metallization technology to ensure good grounding, does not require additional grounding measures, and is simple and convenient to use. The back of the chip is metallized, which is suitable for eutectic sintering or conductive adhesive bonding processes.

Use restriction parameter <sup>1</sup>	
Maximum input voltage	2.5V
Maximum input power	+33dBm CW
Operating temperature	-55 ~ +85°C
storage temperature	-65 ~ +150°C

【1】 Exceeding any of these maximum limits may cause permanent damage.

Electrical performance parameters ( TA = +25°C)				
index	Minimum	Typical Value	Maximum	unit
Frequency Range	2-20			GHz
Insertion loss	-	0.9	1.3	dB
Isolation	43	59	-	dB
Input return loss	18	19	-	dB
Output return loss	17	20	-	dB
P-1dB @17GHz	-	27	-	dBm
Switching speed	-	20	-	ns

## GaAs PIN Reflective SP4T Switch Chip, 2 - 20 GHz

### Main index test curve

Insertion Loss vs. Operating Frequency

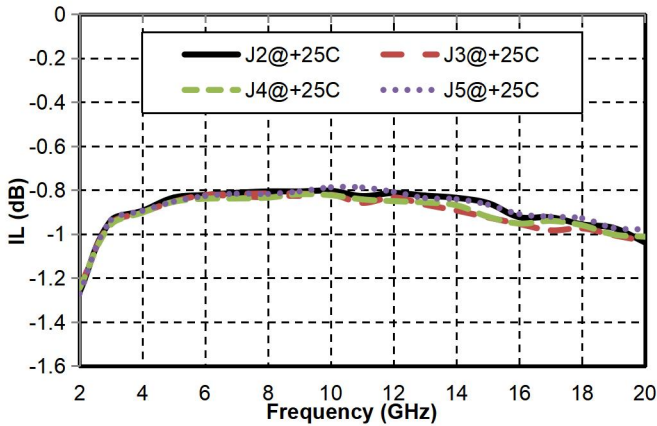

Isolation vs. Operating Frequency

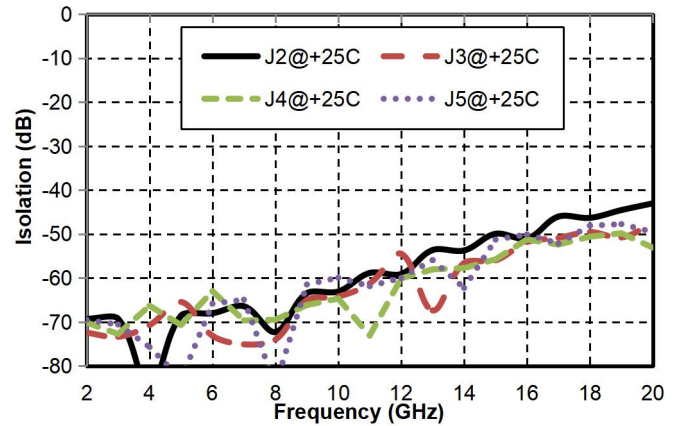

Input Return Loss vs. Frequency

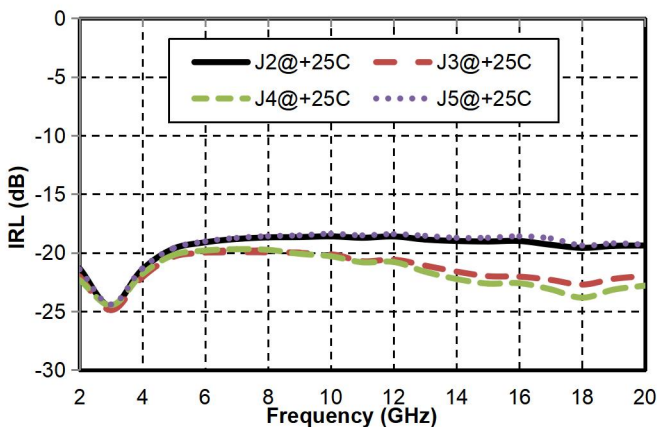

Output Return Loss vs. Frequency

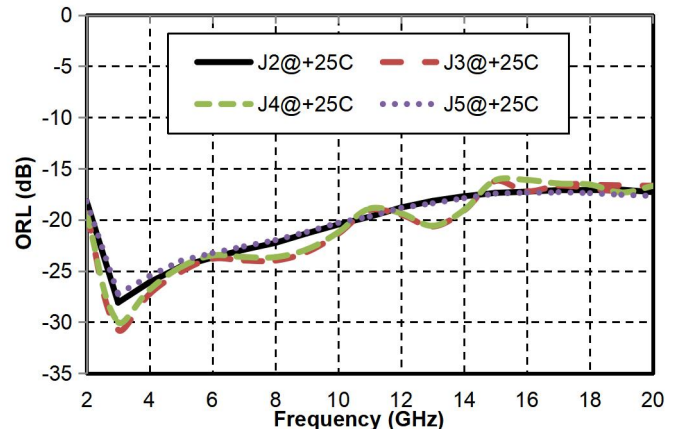

### Typical Driver Connections

CONTROL LEVEL (DC CURRENT)				RF OUTPUT STATE			
VC1	VC2	VC3	VC4	J2-J1	J3-J1	J4-J1	J5-J1
-10mA	+ 20mA	+ 20mA	+ 20mA	Low Loss	Isolation	Isolation	Isolation
+20mA	-10mA	+20mA	+20mA	Isolation	Low Loss	Isolation	Isolation
+20mA	+20mA	-10mA	+20mA	Isolation	Isolation	Low Loss	Isolation
+20mA	+ 20mA	+ 20mA	-10mA	Isolation	Isolation	Isolation	Low Loss

Note: V = +1.35 V , I = +20mA; V = -3.2V, I = -10mA (including J1 on-chip resistor RIN = 50 ohm voltage divider)

## GaAs PIN Reflective SP4T Switch Chip, 2-20GHz

### Appearance structure

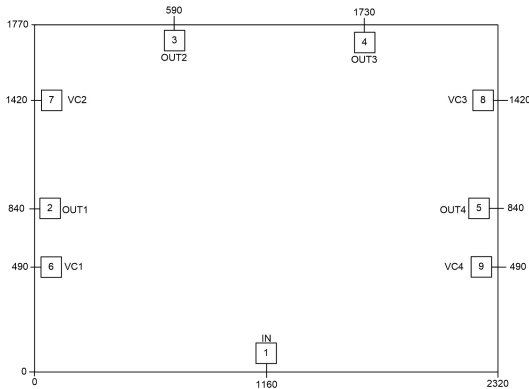

All units in the figure are micrometers

### Bonding point definition

Bonding point number	Function Symbol	Functional Description
1 ,	IN(J1)	RF input signal terminal
2, 3, 4, 5	OUT1(J2), OUT2(J3), OUT3(J4), OUT4(J5)	RF output signal terminal
6, 7, 8, 9	VC1, VC2, VC3, VC4	Signal control terminal
Chip bottom	GND	The bottom of the chip needs to be well grounded to RF and DC

### Recommended circuit diagram

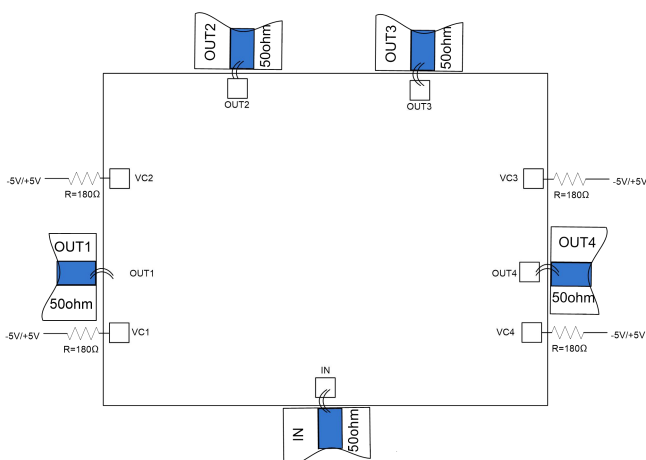

+5V is connected in series with R=180 ohm resistor , V =+ 1.35V , I=+20mA . -5V is connected in series with R=180 ohm resistor , V=-3.2V, I=-10mA .

Note: If you need to reduce power consumption, you need to connect +5V /-5V in series with resistors of different resistance values. For example: +5V in series with R=370 ohm resistor :  $V=+1.3V$ ,  $I=+10mA$ ; -5V in series with R=180 ohm resistor  $V=-3.2V$ ,  $I=-10mA$  . (Including the internal resistor  $R_{IN}=50$  ohm voltage divider at J1 end ). Please contact the manufacturer for specific usage.