

GaAs MMIC Monolithic Integrated 0 Degree Power Divider , 6-18 GHz

Performance characteristics

- Frequency range: 6-18 GHz
- Insertion loss : 0.9 dB
- Isolation: 26dB
- Phase imbalance:1.2°
- Amplitude imbalance: 0.2dB
- 50Ohm input / output
- Chip size: QFN 3X3

Product Introduction

The GPD-0618A-PQ3 monolithic integrated 0- degree power divider has low insertion loss, good isolation, and low phase and amplitude imbalance in the frequency range of 6 ~ 18 GHz , and is very suitable for microwave hybrid integrated circuits and multi-chip modules. The chip adopts a 3 x 3 mm plastic surface mount package, and the surface of the pin pad is gold-plated, which is suitable for reflow soldering installation process.

Use restriction parameter ¹	
Maximum input power	+40dBm
Operating temperature	-55 ~ +85°C
Storage temperature	-65 ~ +150°C

【1】 Exceeding any of these maximum limits may cause permanent damage.

Electrical performance parameters (TA = +25°C)				
Index	Minimum	Typical Value	Maximum	Unit
Frequency Range	6-18			GHz
Insertion loss	-	1.6	2.0	dB
Insertion loss fluctuation		± 0.45		dB
Isolation	-	21	-	dB
Phase imbalance	-	1.2	-	degree
Amplitude imbalance	-	-	0.2	dB
Input return loss	-	16	-	dB
Output return loss	-	16	-	dB

GaAs MMIC Monolithic Integrated 0 Degree Power Divider , 6-18 GHz

Main index test curve

Insertion Loss vs. Operating Frequency

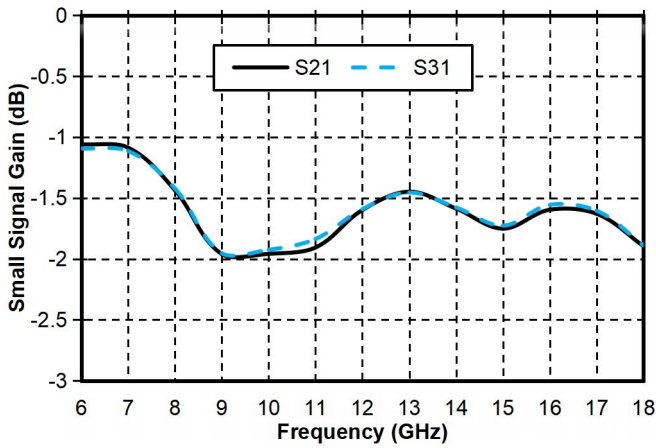

Isolation vs. Operating Frequency

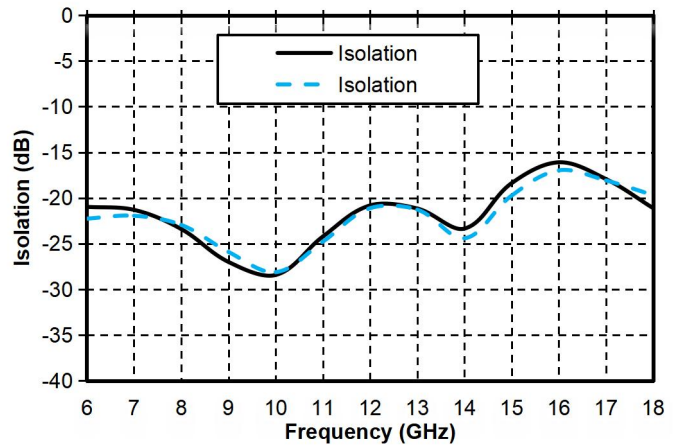

Input Return Loss vs. Operating Frequency

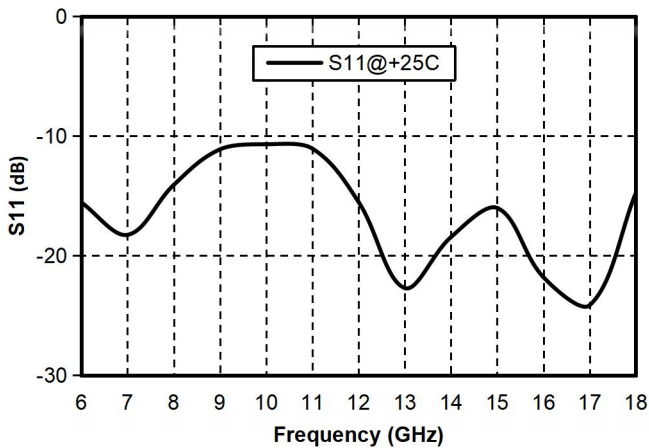

Output Return Loss vs. Operating Frequency

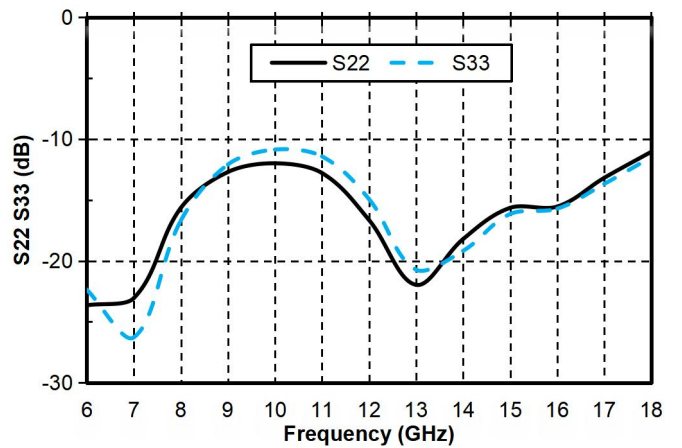

Appearance

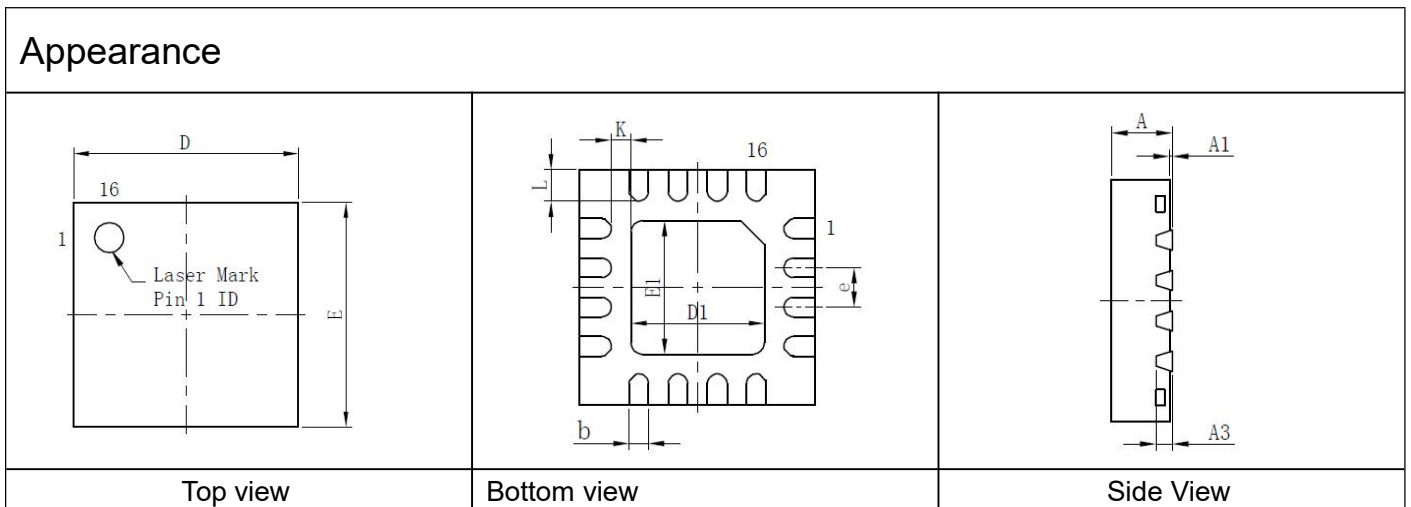

GaAs MMIC Monolithic Integrated 0 Degree Power Divider , 6-18 GHz

Structure size							
Annotation	Minimum	Standard	Maximum	Annotation	Minimum	Standard	Maximum
A	0.70	0.75	0.80	D1	1.60	1.70	1.80
A1	0.00	-	0.05	E1	1.60	1.70	1.80
A3	0.203REF			e	0.5TYP		
b	0.20	0.25	0.30	K	0.20	-	-
D	2.90	3.00	3.10	L	0.30	0.40	0.50
E	2.90	3.00	3.10				

All units in the figures are millimeters .

Pin Definition		
Bonding point number	Function Symbol	Functional Description
3	RFIN	RF signal input terminal
7, 14	RFOUT	RF signal output terminal
2, 4, 6, 8, 13, 15	GND	The bottom of the chip needs to be well grounded to RF and DC
Other	NC	Pin floating; can be grounded

Recommended assembly drawing

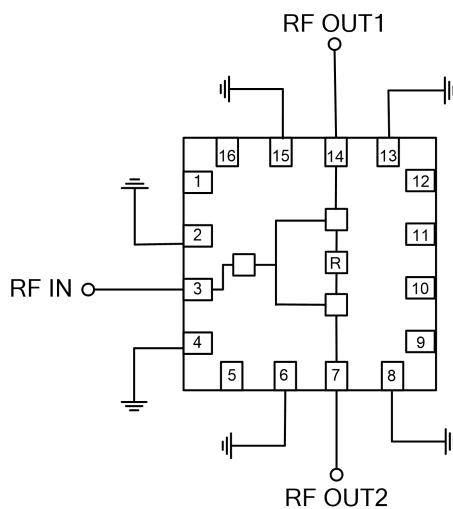

Precautions for use

- Sealing material : Low-pressure injection molding plastic that meets ROHS specifications
- Lead frame material: copper alloy
- Lead surface plating: 100% matte tin
- Maximum reflow peak temperature: 260 °C