

## GaAs MMIC Monolithic Integrated 0 Degree Power Divider , 2-6 GHz

### Performance characteristics

- Range : 2-6GHz
- Insertion loss : 1.0 dB
- Isolation: 24dB
- Phase imbalance: 3.5 °
- Amplitude imbalance: 0.1dB
- 50Ohm input / output
- Chip size: QFN 4X4

### Functional Block Diagram

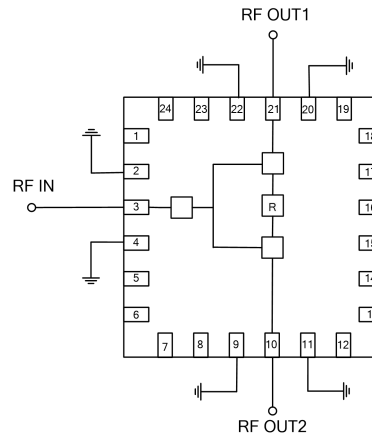

### Product Introduction

The GPD-0206-CQ4 monolithic integrated 0 degree power divider has low insertion loss and good isolation in the frequency range of 2 ~ 6 GHz , making it very suitable for microwave hybrid integrated circuits and multi-chip modules. This chip uses a 4 x 4 mm ceramic surface mount package to achieve airtight packaging, and the surface of the pin pad is gold-plated, which is suitable for reflow soldering installation.

#### Use restriction parameter <sup>1</sup>

Maximum input power	+40dBm
Operating temperature	-55 ~ +85°C
Storage temperature	-65 ~ +150°C

**【1】** Exceeding any of these maximum limits may cause permanent damage.

#### Electrical performance parameters ( TA = +25°C)

Index	Minimum	Typical Value	Maximum	Unit
Frequency Range	2-6			GHz
Insertion loss	-	1.0	1.4	dB
Insertion loss fluctuation		± 0.2		dB
Isolation	-	24	-	dB
Phase imbalance	-	3.5	5	degree
Amplitude imbalance	-	-	0.2	dB
Input return loss	-	22	-	dB
Output return loss	-	22	-	dB



## GaAs MMIC Monolithic Integrated 0 Degree Power Divider , 2-6 GHz

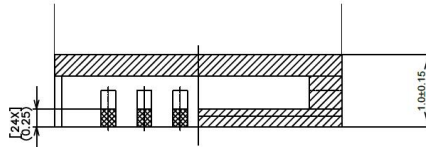

Side View

All units in the figures are millimeters .

Pin Definition		
Bonding point number	Function Symbol	Functional Description
3	RFIN	RF signal input terminal, no DC blocking capacitor required
10, 21	RFOUT1,2	RF signal output terminal, no DC blocking capacitor required
2, 4, 9, 11, 20, 22	GND	The bottom of the chip needs to be well grounded to RF and DC
Other	NC	No welding required, can be grounded

### Precautions for use

- Sealing material : Ceramic material that meets ROHS standards
- Lead frame material: copper alloy
- Lead surface plating: gold, gold layer thickness greater than 1.5um
- Maximum reflow peak temperature: 260 °C