

## GaAs MMIC Power Amplifier Chip, 20-40GHz

### Performance characteristics

Frequency range: 20-40GHz  
 Small Signal Gain: 21 dB  
 Gain flatness:  $\leq \pm 0.75$ dB  
 Noise figure: 7.0dB typ.  
 P-1dB: 22dBm  
 Psat: 23 dBm  
 Power supply: +5 V/ 180 mA  
 50Ohm input/output  
 100% on-chip testing  
 Chip size: 1.85 x 1.05 x 0.1mm

### Functional Block Diagram

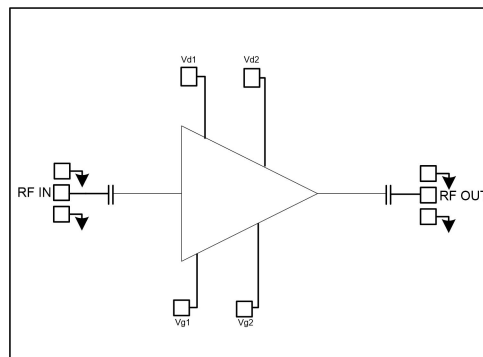

### Product Introduction

GPA-2040C is a broadband amplifier chip based on GaAs technology, covering a frequency range of 20~40GHz, a small signal gain of 21dB, and a saturated output power of 23dBm. The chip is powered by a +5V power supply. The chip through-hole metallization process ensures good grounding, and the back side is metallized, which is suitable for eutectic sintering or conductive adhesive bonding process.

#### Use restriction parameter <sup>1</sup>

Maximum drain voltage	+7 V
Maximum gate bias	-3V
Maximum input power	+20dBm
Operating temperature	-55 ~ + 85 °C
Storage temperature	-65 ~ +150°C

【1】 Exceeding any of these maximum limits may cause permanent damage.

#### Electrical performance parameters ( TA = +25°C , Vd = +5V )

Index	Minimum	Typical Value	Maximum	Unit
Frequency Range	20-40			GHz
Small Signal Gain	20	21	23	dB
Gain Flatness		$\pm 0.75$		dB
P -1 dB		22		dBm
Psat		23		dBm
Input return loss	16	21	-	dB
Output return loss	12	14	-	dB
Quiescent Current		180		mA

\* By tuning the Vg terminal voltage from -2V to 0V , 180 mA is achieved , and the Vg terminal voltage is expected to be -0.7 V.

## GaAs MMIC Power Amplifier Chip, 20-40GHz

Main index test curve (the following data is based on probe test)

Gain vs. Frequency

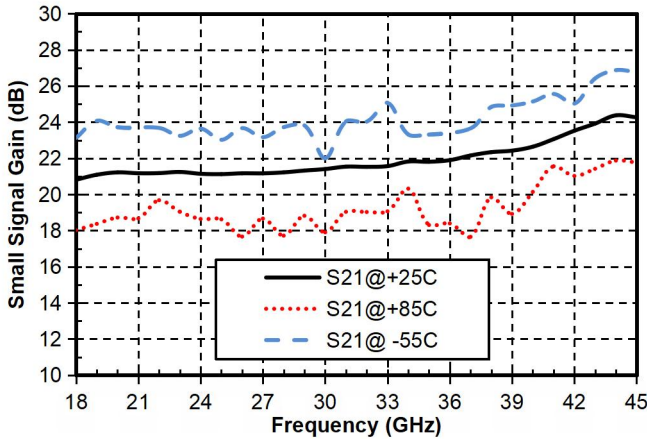

Reverse Isolation vs. Frequency

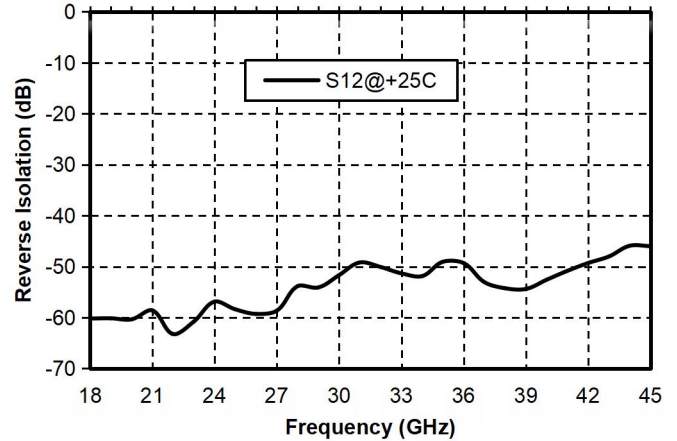

Input Return Loss vs. Frequency

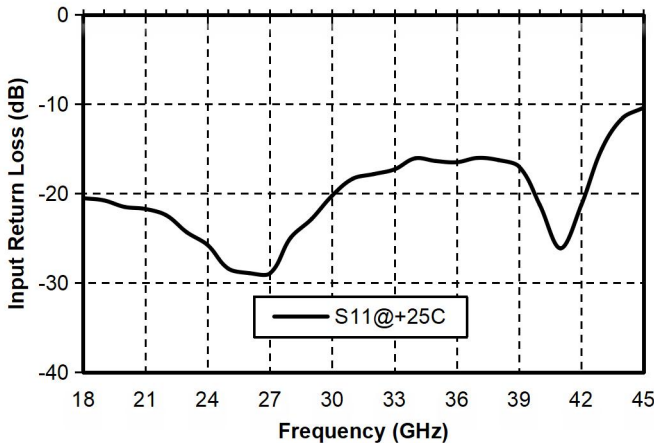

Output Return Loss vs. Frequency

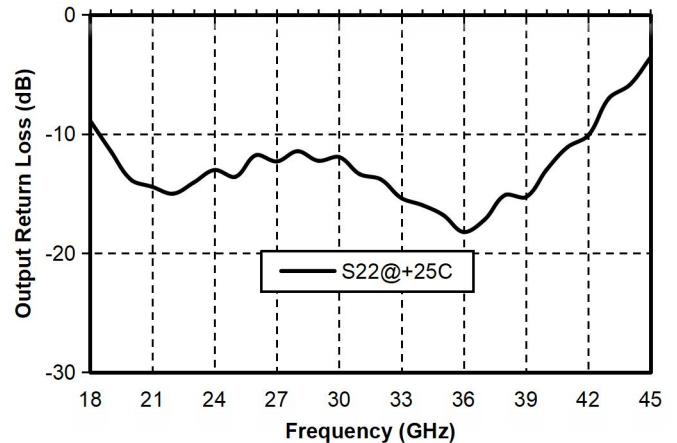

P-1dB vs. Frequency

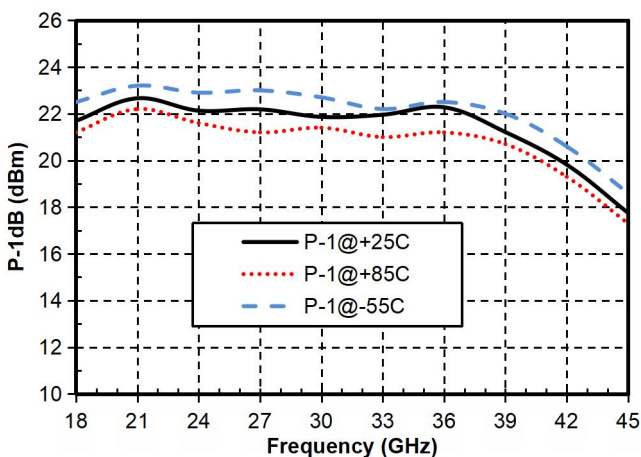

Psat vs. Frequency

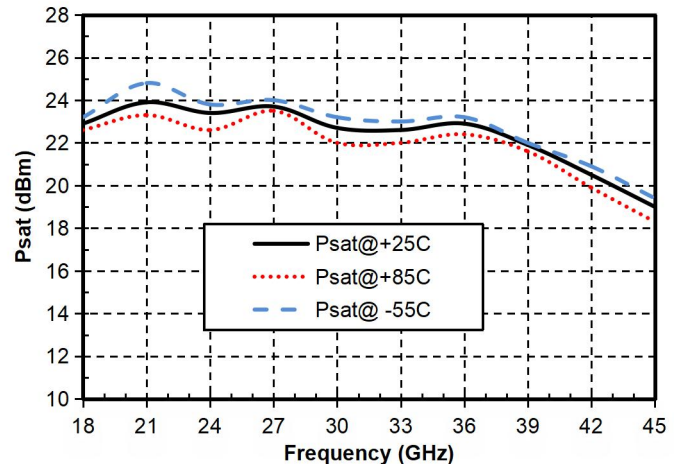

## GaAs MMIC Power Amplifier Chip, 20-40GHz

### Appearance structure <sup>2</sup>

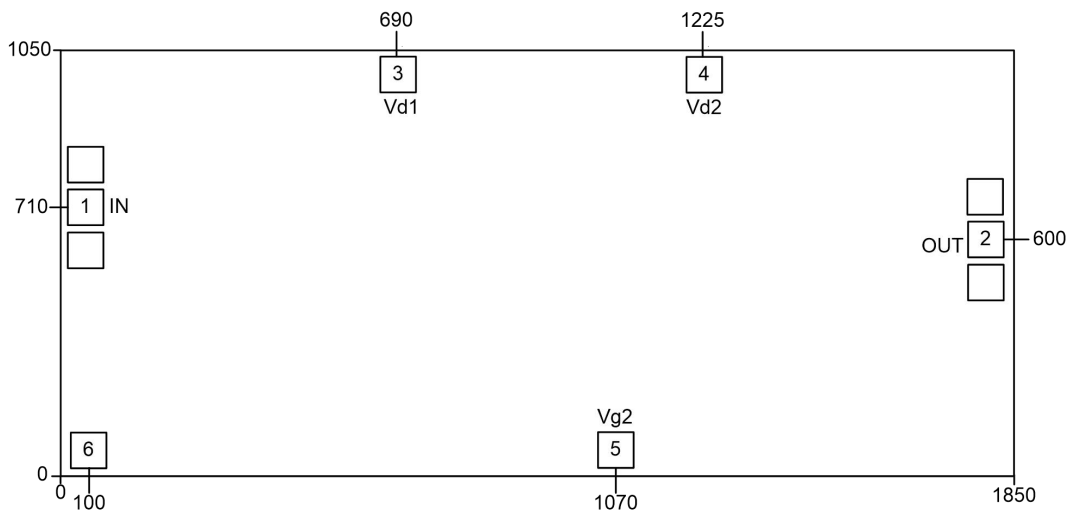

【 2 】 All units in the figure are micrometers

### Bonding point definition

Bonding point number	Function Symbol	Functional Description
1	RF IN	RF signal input terminal, no DC blocking capacitor required
2	RF OUT	RF signal output terminal, no DC blocking capacitor required
3,4	Vd 1, Vd 2	Amplifier drain bias, requires external 100 pF, 1000pF, 100nF bypass capacitor
5, 6	Vg1, Vg2	Amplifier gate bias, external 100 pF, 1000 pF, 100 nF bypass capacitor required
Chip bottom	GND	The bottom of the chip needs to be in good contact with the RF and DC grounds

## GaAs MMIC Power Amplifier Chip, 20-40GHz

### Recommended assembly diagram

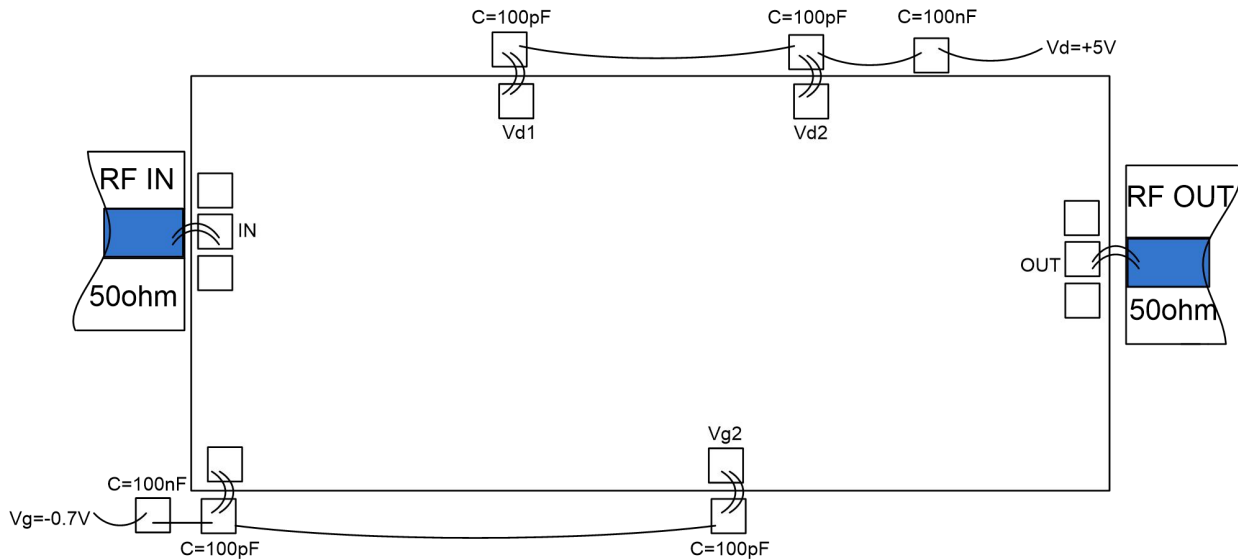

### Notice

- The chip must be stored in an anti-static container and kept in a nitrogen environment.
- Do not attempt to clean the bare die surface using wet chemical methods.
- Please strictly follow the ESD protection requirements to avoid static damage to the bare chip.
- General operation: Please use precision pointed tweezers to pick up bare chips. Avoid touching the chip surface with tools or fingers during operation.
- Rack mounting operation suggestions: Bare chip mounting can be done by AuSn solder eutectic sintering or conductive adhesive bonding. The mounting surface must be clean and flat.
- Sintering process: It is recommended to use AuSn solder sheets with a gold-tin ratio of 80/20. The working surface temperature reaches 255 °C and the tool (vacuum chuck) temperature reaches 265 °C . When the high-temperature mixed gas (nitrogen-hydrogen ratio of 90/10) is blown to the chip, the temperature at the top of the tool should be raised to 290 °C . Do not let the chip exceed 320 °C for more than 20 seconds. The friction time should not exceed 3 seconds.
- Bonding process: The amount of conductive glue dispensed should be as small as possible. After the chip is placed in the installation position, the conductive glue can be vaguely seen around it. For curing conditions, please follow the information provided by the conductive glue manufacturer.
- Bonding operation suggestions: Use  $\Phi 0.025\text{mm}$  (1mil) gold wire for both ball and wedge bonding. Thermosonic bonding temperature is 150 °C . The pressure of the wedge bonding knife is 40~50gf for ball bonding and 18~22gf for wedge bonding. Use the smallest possible ultrasonic energy. The bonding starts at the pressure point on the chip and ends at the package (or substrate).