

GaAs MMIC Power Amplifier Chip, 18-44GHz

Performance characteristics

Frequency range: 18-44GHz

Small Signal Gain: 22.5 dB

Gain flatness : ± 3.2 dB

P-1dB: 29.5 dBm

Psat: 30 dBm

Power supply: + 5V@1350mA

50Ohm input/output

100% on-chip testing

Chip size: 3.52 x 2.75 x 0.1mm

Product Introduction

GPA -1844H is a broadband power amplifier chip based on GaAs process , covering the frequency range of 18 ~44GHz, small signal gain of 22.5dB, Psat output power of 30dBm. The amplifier operates with +5V. The chip through-hole metallization process ensures good grounding, and the back side is metallized for eutectic sintering process.

Use restriction parameter ¹

Maximum drain voltage	+9 V
Maximum gate bias	- 3 V
Maximum input power	+25 dBm
Operating temperature	-55 ~ +85°C
Storage temperature	-65 ~ +150°C

【1】 Exceeding any of these maximum limits may cause permanent damage.

Electrical parameters (Ta=+25°C, Vd = +5 V, Vg=-0.7V, Ids= 1350 mA)

index	Minimum	Typical Value	Maximum	unit
Frequency Range	18-44			GHz
Small Signal Gain	-	22.5	-	dB
Gain Flatness	± 3.2			dB
P-1dB	-	29.5	-	dBm
Psat	-	30	-	dBm
Input return loss	-	15	-	dB
Output return loss	-	19	-	dB

* By tuning the Vg terminal voltage -2V~0V , the recommended gate voltage is -0.7V.

GaAs MMIC Power Amplifier Chip, 18-44GHz

Main index test curve

Gain vs. Frequency

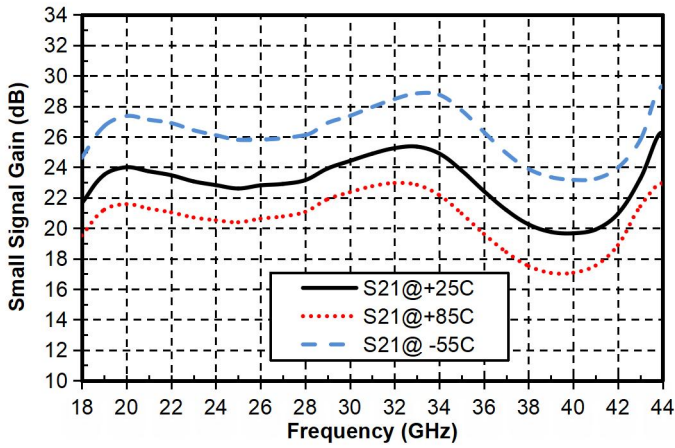

Reverse Isolation vs. Frequency

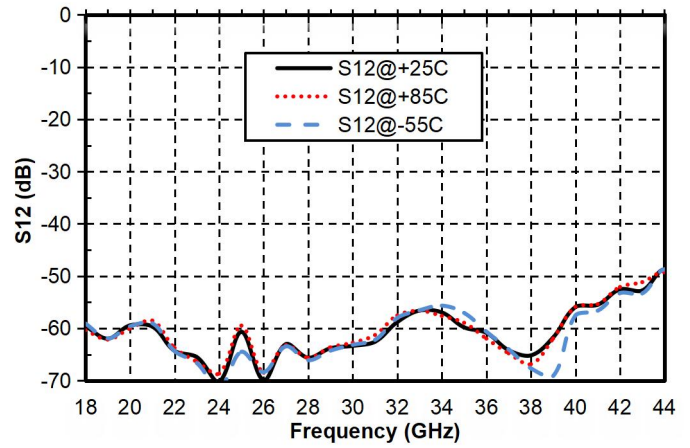

Input Return Loss vs. Frequency

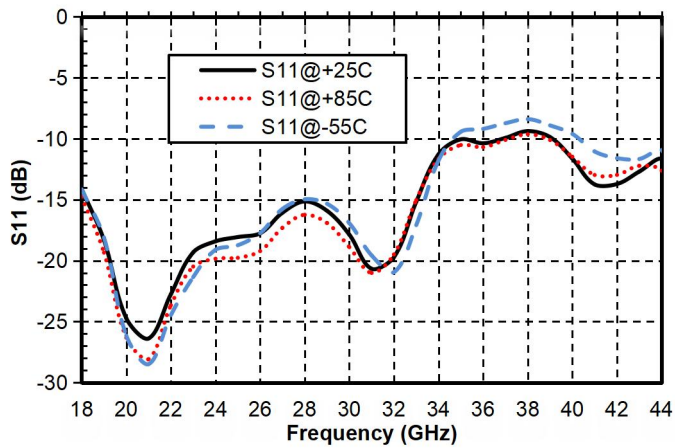

Output Return Loss vs. Frequency

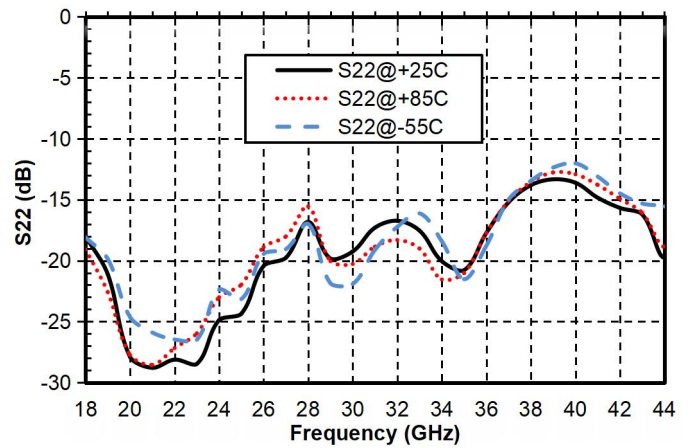

P-1dB vs. Frequency

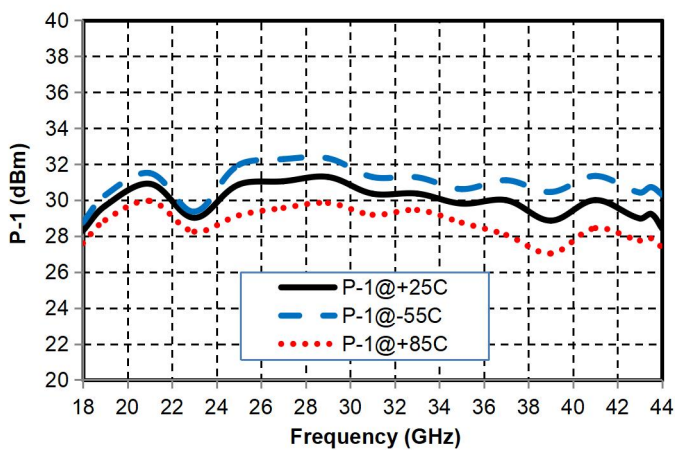

Psat vs. Frequency

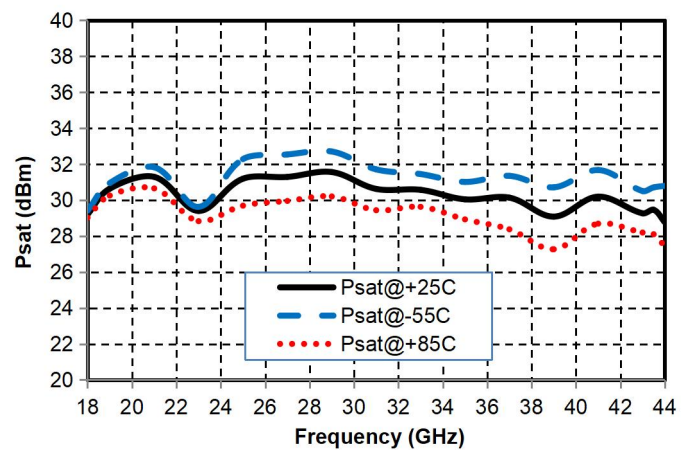

GaAs MMIC Power Amplifier Chip, 18-44GHz

Appearance structure

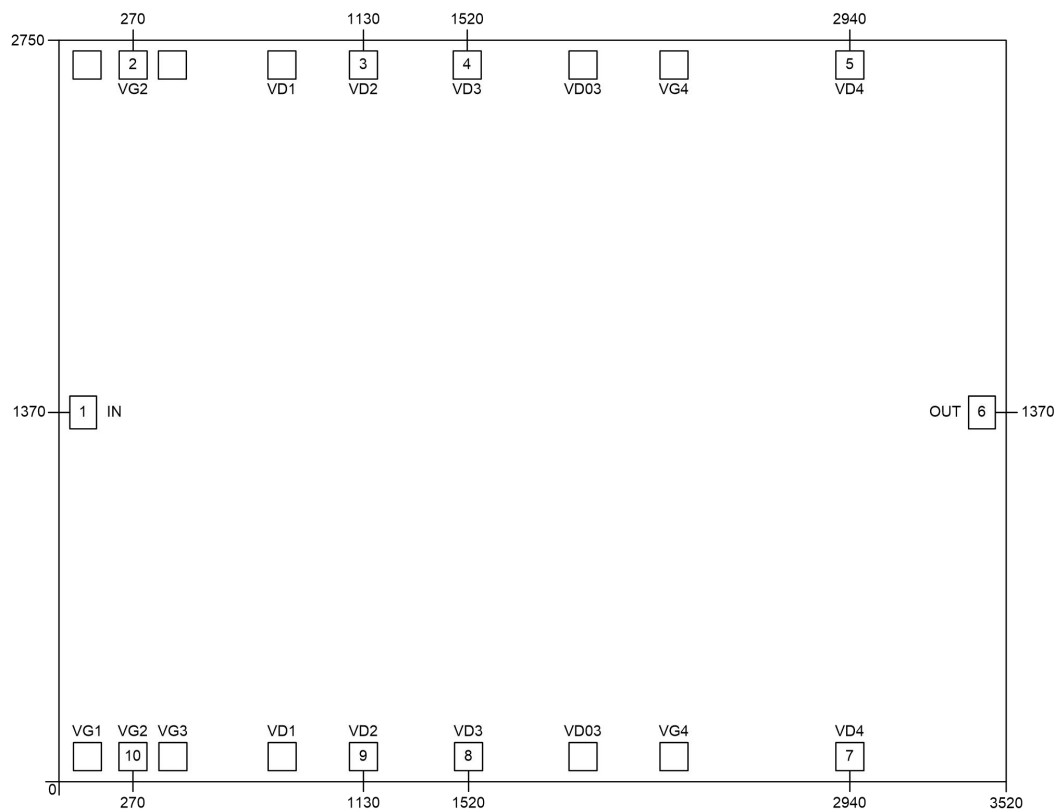

The unit in the figure is micrometer

Bonding point definition		
Bonding point number	Function Symbol	Functional Description
1	RF IN	The signal input terminal is connected to a 50 ohm circuit, and no DC blocking capacitor is required.
6	RF OUT	The signal output terminal is connected to a 50 ohm circuit, and no DC blocking capacitor is required.
3, 4, 5, 7, 8, 9	V D2~4	Amplifier drain bias, external 100pF , 1000pF , 4.7uF bypass capacitors are required.
2,10	VG2	Amplifier gate bias , external 100pF , 1000pF , 4.7uF bypass capacitors are required.
Chip bottom	GND	needs to be in good contact with the RF and DC grounds.

GaAs MMIC Power Amplifier Chip, 18-44GHz

Recommended assembly diagram

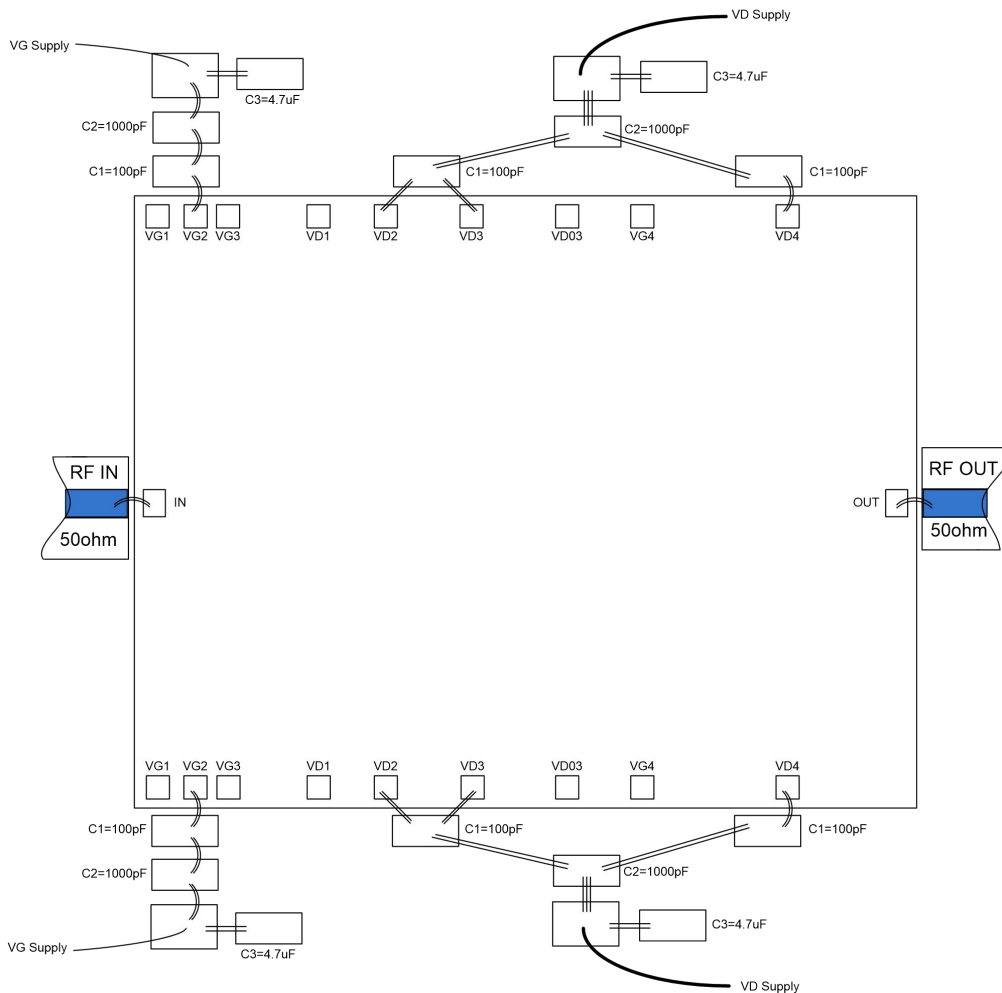

Notice

1. The single-chip circuit needs to be stored in a dry and clean N2 environment;
2. The chip substrate material 6H-SiC is very brittle and must be used with care to avoid damaging the chip;
3. There is no insulating protective layer on the chip surface, so attention should be paid to the cleanliness of the assembly environment to avoid excessive contamination of the surface ;
4. The thermal expansion coefficient of the carrier should be close to that of 6H-SiC , with a linear thermal expansion coefficient of $4.2 \times 10^{-6} / ^\circ\text{C}$. It is recommended that CuMoCu be used as the carrier material. CuMo or CuW ;
5. Avoid holes between the chip and the carrier during assembly, and ensure good heat dissipation between the box and the carrier;
6. It is recommended to use gold-tin solder for sintering, Au: Sn = 80%: 20%, the sintering temperature should not exceed $300\text{ }^\circ\text{C}$, the time should not be longer than 30 seconds, and the sintering process should avoid rapid temperature changes and need to gradually increase and decrease the temperature;

7. It is recommended to use gold wire with a diameter of 25 μ m to 30 μ m , the temperature of the bonding platform chassis should not exceed 250 °C, the bonding time should be as short as possible, and the bonding process should avoid rapid temperature changes;
8. When power is on, the gate voltage is increased first and then the drain voltage is increased. When power is off, the drain voltage is reduced first and then the gate voltage is reduced.
9. has DC blocking capacitors for input and output , but the input end has a DC short-circuit structure to ground;
10. Pay attention to anti-static during chip use and assembly, wear a grounded anti-static bracelet, and ensure that the sintering and bonding tables are well grounded .