

## GaAs MMIC Power Amplifier Chip, 12-20GHz

### Performance characteristics

Frequency range: 12-20GHz  
 Small Signal Gain: 19 dB  
 Gain flatness:  $\pm 0.8$  dB  
 Psat: 25.5 dBm  
 Efficiency: 50%  
 Power supply: +5 V/ 150 mA  
 50Ohm input/output  
 100% on-chip testing  
 Chip size : 1.85 x 1.2 x 0.1mm

### Product Introduction

GPA-1220B is a broadband amplifier chip based on GaAs technology, covering a frequency range of 12~20GHz, with a small signal gain of 19dB and a P-1 output power of 25dBm. The chip is powered by a +5V power supply. The chip's through-hole metallization process ensures good grounding, and the back side is metallized, which is suitable for eutectic sintering or conductive adhesive bonding.

Use restriction parameter <sup>1</sup>	
Maximum drain voltage	+7 V
Maximum input power	+20dBm
Operating temperature	-55 ~ + 85 °C
Storage temperature	-65 ~ +150°C

【1】 Exceeding any of these maximum limits may cause permanent damage.

Electrical performance parameters ( TA = +25°C , Vd = +5V, Vg = -0.8V, Ids = 150 mA)				
Index	Minimum	Typical Value	Maximum	Unit
Frequency Range	12-20			GHz
Small Signal Gain	-	19	-	dB
Gain Flatness		$\pm 0.8$		dB
P -1 dB	-	25	-	dBm
Psat	-	25.5	-	dBm
efficiency		50		%
Input return loss	-	twenty three		dB
Output return loss	-	16		dB
Quiescent Current		150		mA

\* By tuning the Vg terminal voltage -2V~0V , the recommended gate voltage is -0.8V.

## GaAs MMIC Power Amplifier Chip, 12-20GHz

Main index test curve

Gain vs. Frequency

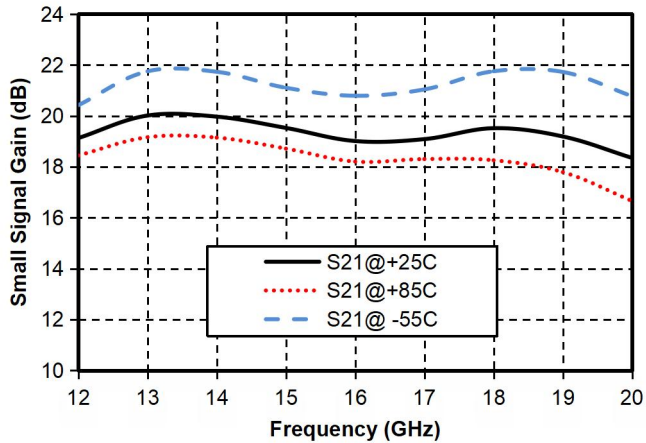

Reverse Isolation vs. Frequency

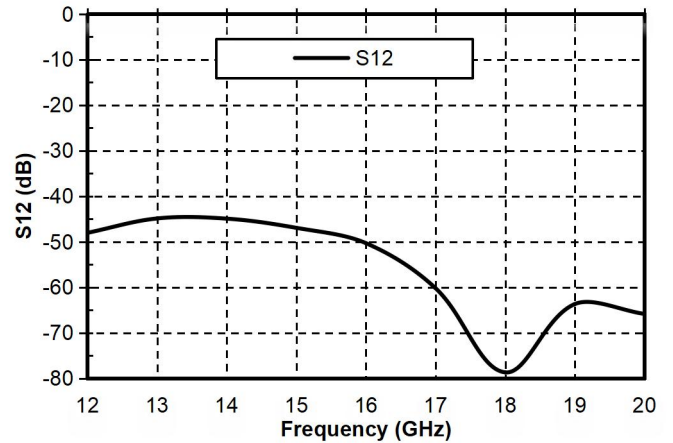

Input Return Loss vs. Frequency

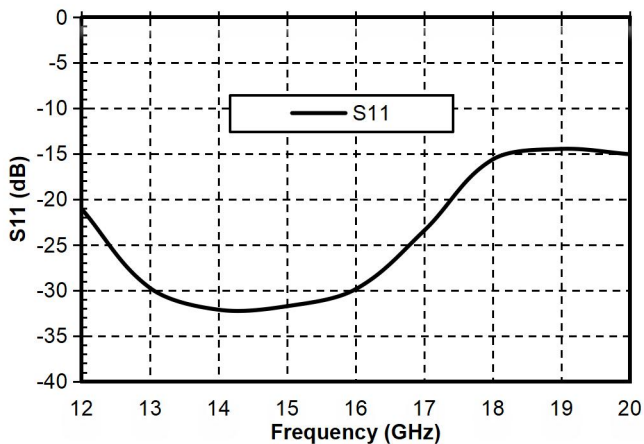

Output Return Loss vs. Frequency

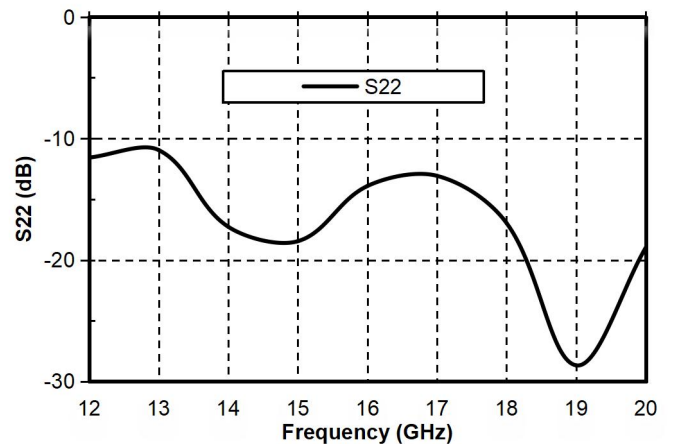

Psat vs. Frequency

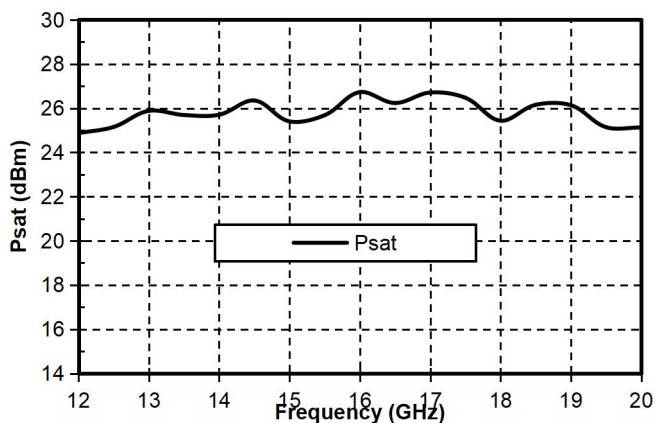

Dynamic Current vs. Frequency

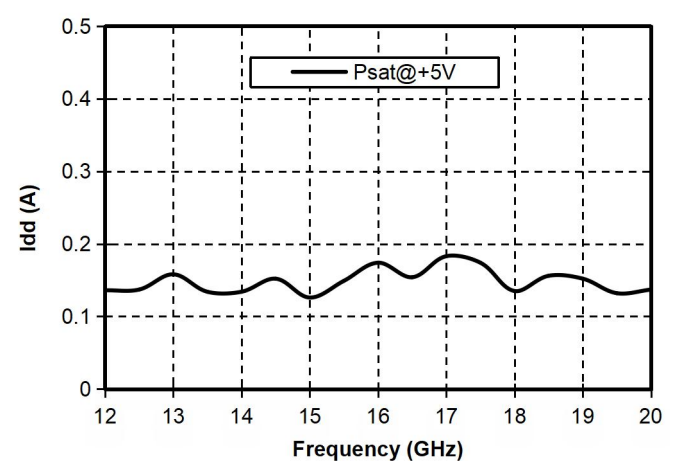

## GaAs MMIC Power Amplifier Chip, 12-20GHz

Appearance structure <sup>2</sup>

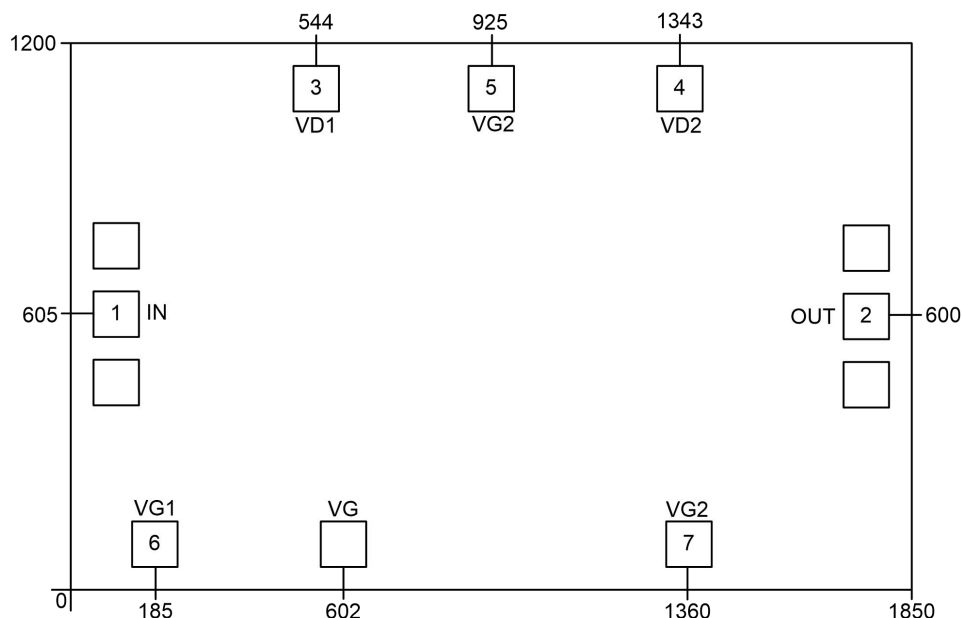

【 2 】 The units in the figure are all micrometers ( dimensional tolerance:  $\pm 100\mu\text{m}$ .)

Bonding point definition		
Bonding point number	Function Symbol	Functional Description
1	RF IN	RF signal input terminal, no DC blocking capacitor required
2	RF OUT	RF signal output terminal, no DC blocking capacitor required
3,4	Vd 1~Vd2	Amplifier drain bias, external 100pF, 1000pF bypass capacitor required
5, 6, 7	Vg1-Vg2	Amplifier gate bias, external 100pF, 1000pF bypass capacitor required
Chip bottom	GND	The bottom of the chip needs to be in good contact with the RF and DC grounds

## GaAs MMIC Power Amplifier Chip, 12-20GHz

### Recommended assembly diagram

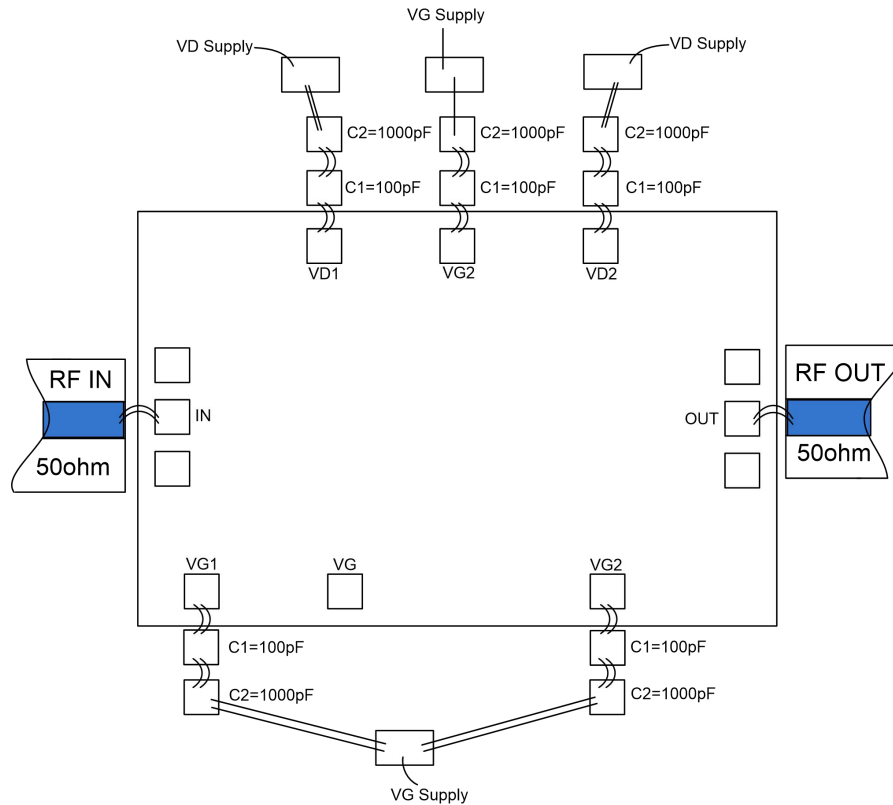

### Notice

- The chip must be stored in an anti-static container and kept in a nitrogen environment.
- Do not attempt to clean the bare die surface using wet chemical methods.
- Please strictly follow the ESD protection requirements to avoid static damage to the bare chip.
- General operation: Please use precision pointed tweezers to pick up bare chips. Avoid touching the chip surface with tools or fingers during operation.
- Rack mounting operation suggestions: Bare chip mounting can be done by AuSn solder eutectic sintering or conductive adhesive bonding. The mounting surface must be clean and flat.
- Sintering process: It is recommended to use AuSn solder sheets with a gold-tin ratio of 80/20. The working surface temperature reaches 255 °C and the tool (vacuum chuck) temperature reaches 265 °C . When the high-temperature mixed gas (nitrogen-hydrogen ratio of 90/10) is blown to the chip, the temperature at the top of the tool should be raised to 290 °C . Do not let the chip exceed 320 °C for more than 20 seconds. The friction time should not exceed 3 seconds.
- Bonding process: The amount of conductive glue dispensed should be as small as possible. After the chip is placed in the installation position, the conductive glue can be vaguely seen around it. For curing conditions, please follow the information provided by the conductive glue manufacturer.
- Bonding operation suggestions: Use  $\Phi 0.025\text{mm}$  (1mil) gold wire for both ball and wedge bonding.

Thermosonic bonding temperature is 150 °C . The pressure of the wedge bonding knife is 40~50gf for ball bonding and 18~22gf for wedge bonding. Use the smallest possible ultrasonic energy. The bonding starts at the pressure point on the chip and ends at the package (or substrate).