

GaAs MMIC Power Amplifier Chip, 5-15.5GHz

Performance characteristics

Frequency range: 5 - 15.5 GHz
 Small Signal Gain: 17.5 dB
 P-1dB: 15 dBm
 Psat: 16 dBm
 Noise figure: 3.3dB
 Power supply: +5 V / 52 mA
 50Ohm input/output
 100% on-chip testing
 Chip size: 2.21 x 1.25 x 0.1 mm

Product Introduction

GPA-0515B is a broadband power amplifier chip based on GaAs technology, with a frequency range of 5~15.5GHz, a small signal gain of 17.5dB, and a P-1 output power of 15dBm. GPA-0515B is powered by a single +5V power supply. The chip through-hole metallization process ensures good grounding, and the back side is metallized, which is suitable for eutectic sintering or conductive adhesive bonding process.

Use restriction parameter ¹

Maximum drain voltage	+7 V
Maximum input power	+20 dBm
Operating temperature	-55 ~ +85°C
storage temperature	-65 ~ +150°C

【1】 Exceeding any of these maximum limits may cause permanent damage.

Electrical Parameters (TA = +25°C, Vd = +5 V)

Index	Minimum	Typical Value	Maximum	Unit
Frequency Range	5-15.5			GHz
Small Signal Gain	17	17.5	20	dB
Gain Flatness	-	± 1 . 5	-	dB
Noise Figure	-	3.3	-	dB
P-1dB	14	15	16	dBm
Psat	15	16	17	dBm
Input return loss	11	13	-	dB
Output return loss	10	20		dB
Quiescent Current		52		mA

GaAs MMIC Power Amplifier Chip, 5-15.5GHz

Main index test curve

Gain vs. Frequency

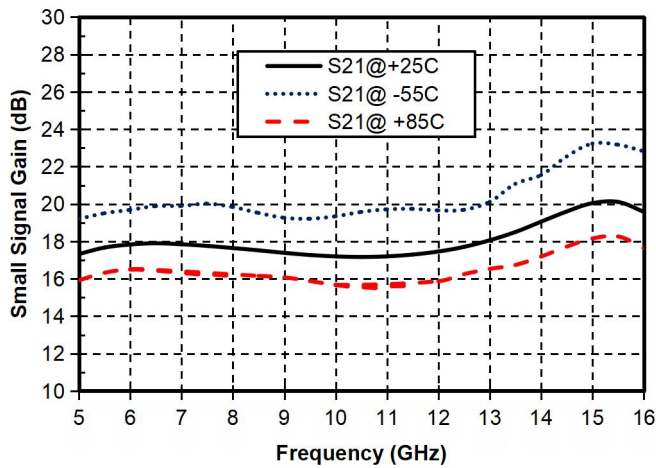

Reverse Isolation vs. Frequency

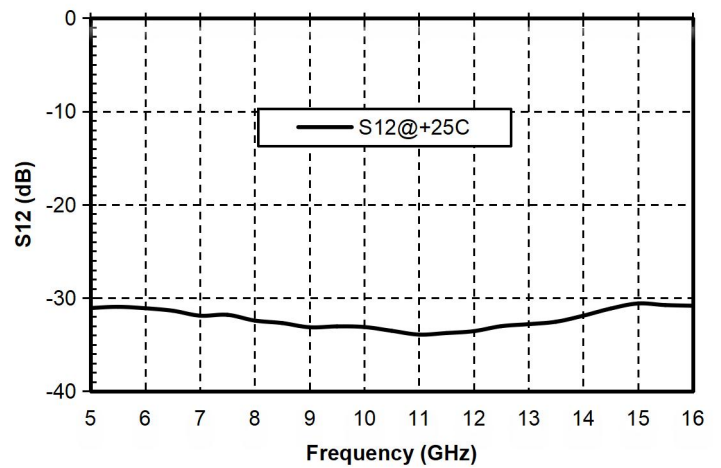

Input Return Loss vs. Frequency

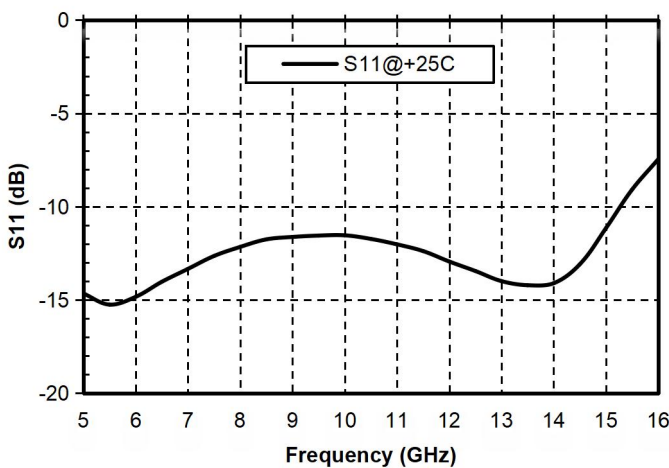

Output Return Loss vs. Frequency

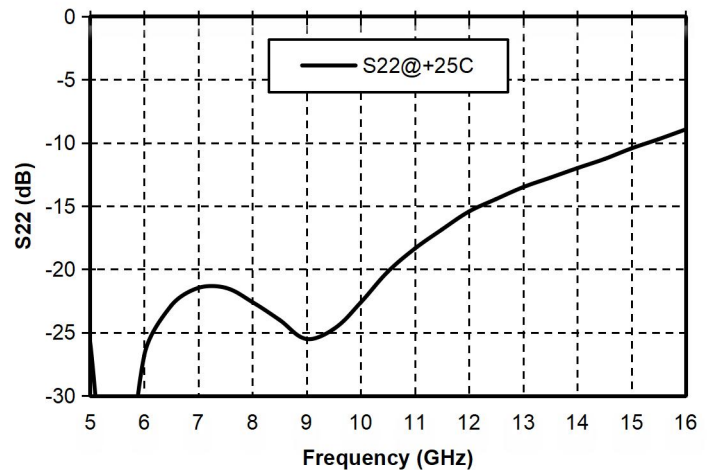

P-1 vs. Frequency

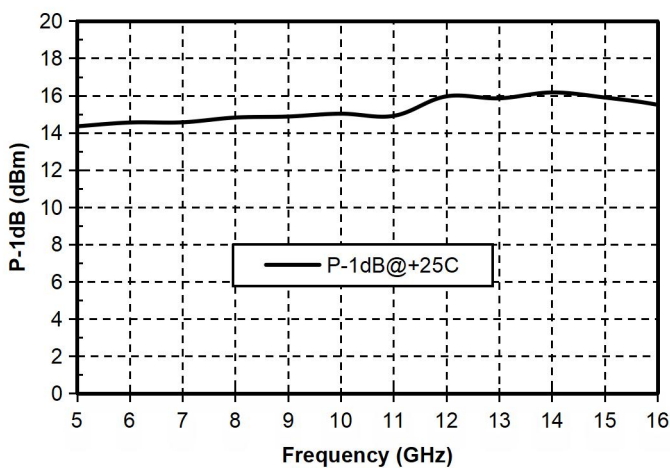

Noise vs. Frequency

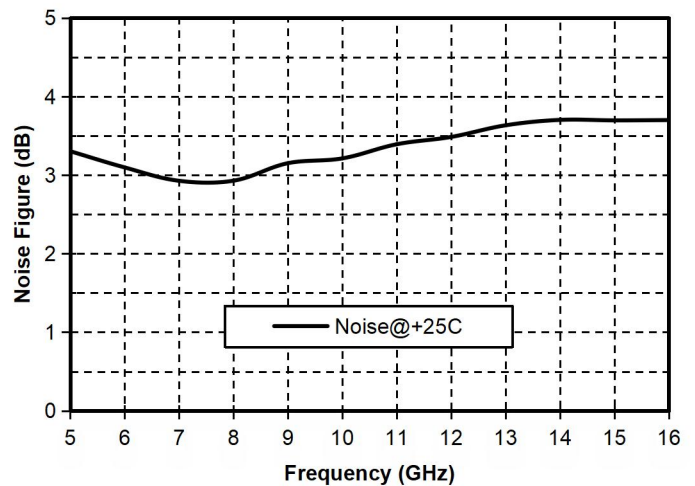

GaAs MMIC Power Amplifier Chip, 5-15.5GHz

Appearance structure ²

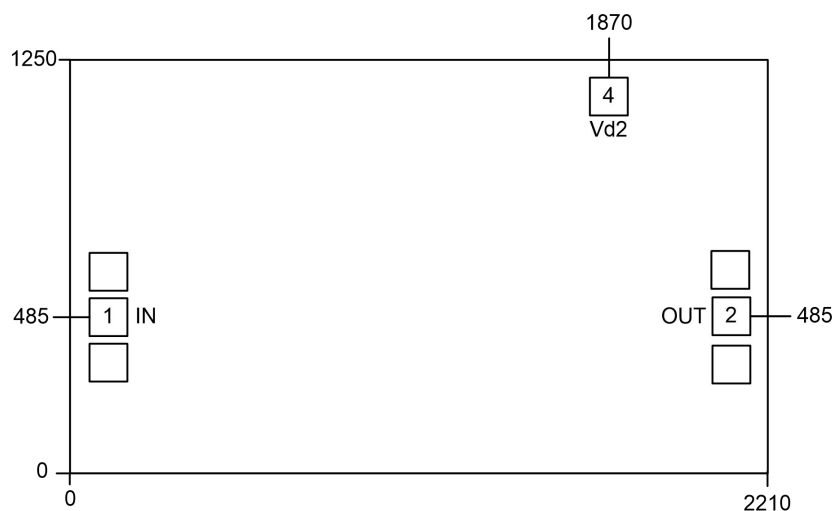

【 2 】 All units in the figure are micrometers

Bonding point definition		
Bonding point number	Function Symbol	Functional Description
1	RFIN	RF signal input terminal, no DC blocking capacitor required.
2	RFOUT	RF signal output terminal, no DC blocking capacitor required
3	V d1	Amplifier drain bias, requires external 100pF bypass capacitor.
Chip bottom	GND	The bottom of the chip needs to be well grounded to RF and DC.

GaAs MMIC Power Amplifier Chip, 5-15.5GHz

Recommended assembly diagram

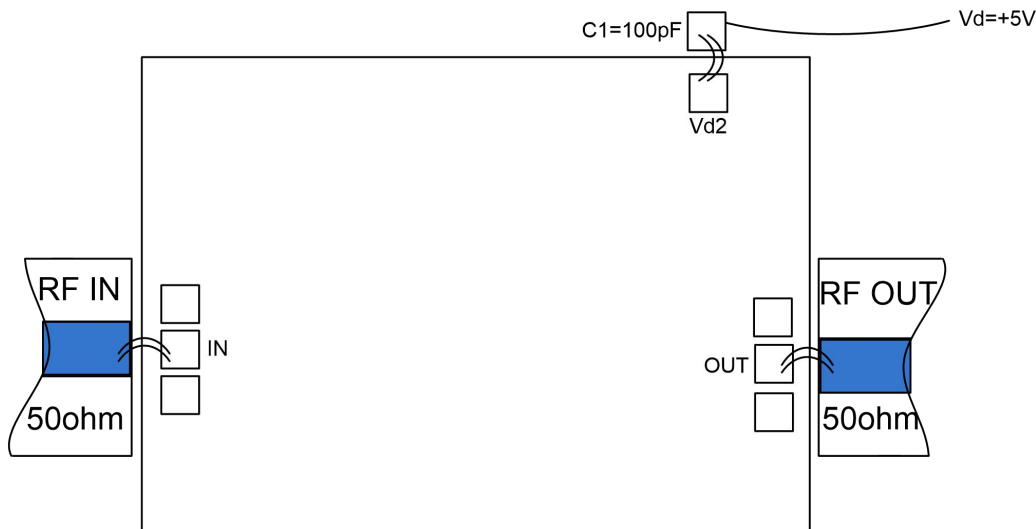

Notice

- The chip must be stored in an anti-static container and kept in a nitrogen environment.
- Do not attempt to clean the bare die surface using wet chemical methods.
- Please strictly follow the ESD protection requirements to avoid static damage to the bare chip.
- General operation: Please use precision pointed tweezers to pick up bare chips. Avoid touching the chip surface with tools or fingers during operation.
- Rack mounting operation suggestions: Bare chip mounting can be done by AuSn solder eutectic sintering or conductive adhesive bonding. The mounting surface must be clean and flat.
- Sintering process: It is recommended to use AuSn solder sheets with a gold-tin ratio of 80/20. The working surface temperature reaches 255 °C and the tool (vacuum chuck) temperature reaches 265 °C . When the high-temperature mixed gas (nitrogen-hydrogen ratio of 90/10) is blown to the chip, the temperature at the top of the tool should be raised to 290 °C . Do not let the chip exceed 320 °C for more than 20 seconds. The friction time should not exceed 3 seconds.
- Bonding process: The amount of conductive glue dispensed should be as small as possible. After the chip is placed in the installation position, the conductive glue can be vaguely seen around it. For curing conditions, please follow the information provided by the conductive glue manufacturer.
- Bonding operation suggestions: Use $\Phi 0.025\text{mm}$ (1mil) gold wire for both ball and wedge bonding. Thermosonic bonding temperature is 150 °C . The pressure of the wedge bonding knife is 40~50gf for ball bonding and 18~22gf for wedge bonding. Use the smallest possible ultrasonic energy. The bonding starts at the pressure point on the chip and ends at the package (or substrate).