

GaAs MMIC Power Amplifier Chip, 4-20 GHz

Performance characteristics

- Frequency Range: 4 - 20 GHz
- Small signal gain: 24dB
- Gain flatness: ± 1.8 dB
- P -1 dB : 20dBm
- Psat : 21dBm
- Power supply: +5 V /160mA
- 50Ohm input / output
- Chip size: QFN 4X4

Block Diagram

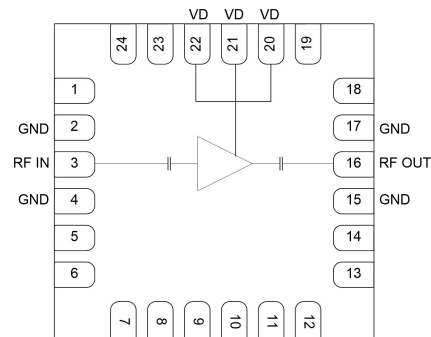

Product Introduction

GPA-0420F-CQ4 is a broadband low noise amplifier chip with a frequency range of 4GHz~20GHz, a small signal gain of 24dB, and a P-1 output of 20dBm. GPA-0420F-CQ4 is powered by a single +5V power supply. This chip uses a 4 x 4 mm ceramic surface mount package to achieve airtight packaging. The surface of the pin pad is gold-plated and is suitable for reflow soldering installation.

Using the Limit Parameter

Maximum drain voltage	+7V
Maximum input power	+20dBm
Operating temperature	-55 ~ +85°C
Storage temperature	-65 ~ +150°C

Exceeding any of these maximum limits may cause permanent damage.

Electrical performance parameters (TA = +25°C , Vd = +5V)

Index	Minimum	Typical Value	Maximum	Unit
Frequency Range	4-20			GHz
Small Signal Gain	-	24	-	dB
Gain Flatness		± 1.8		dB
P -1dB	-	20	-	dBm
Psat	-	21	-	dBm
Input return loss	-	14	-	dB
Output return loss	-	15	-	dB
Quiescent Current		160		mA

GaAs MMIC Power Amplifier Chip, 4 - 20 GHz

Main index test curve

Gain vs. Frequency

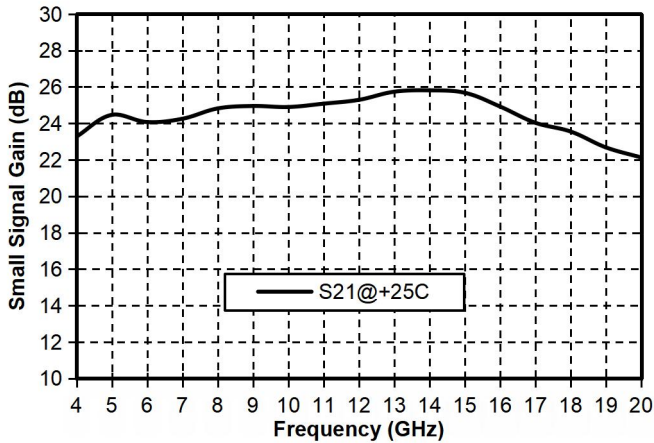

Reverse Isolation vs. Frequency

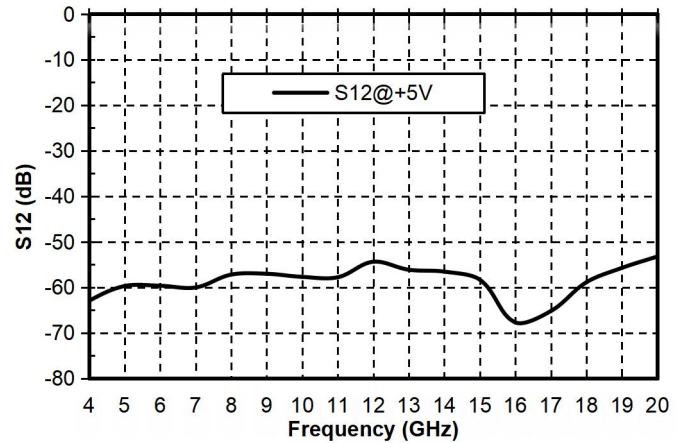

Input Return Loss vs. Frequency

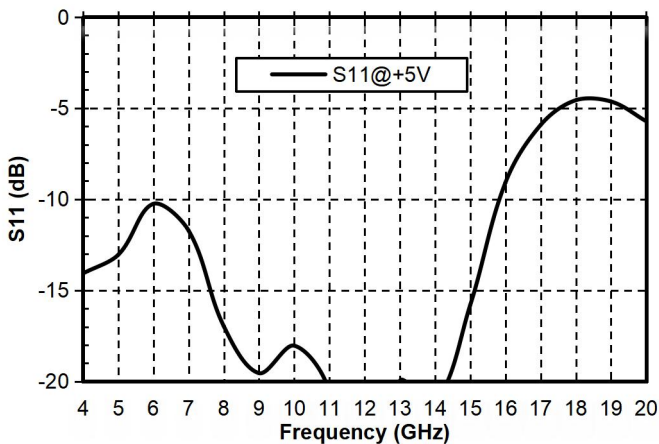

Output Return Loss vs. Frequency

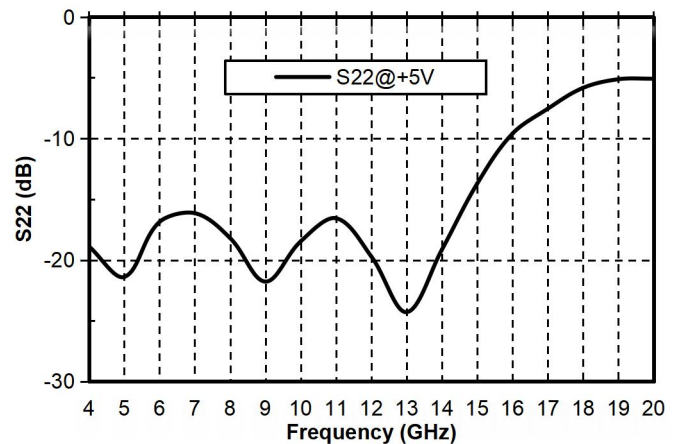

P-1dB vs. Frequency

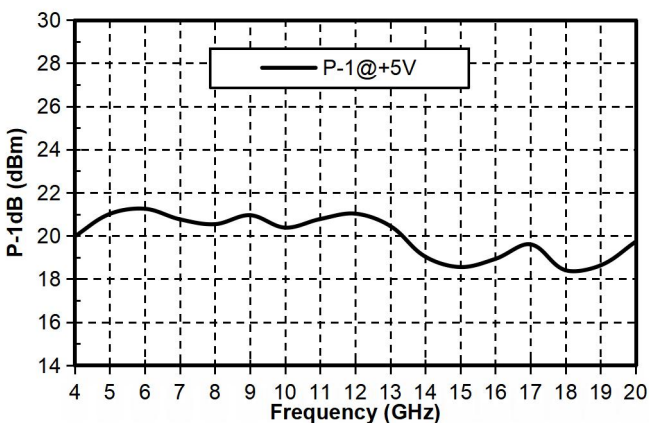

P sat vs. frequency

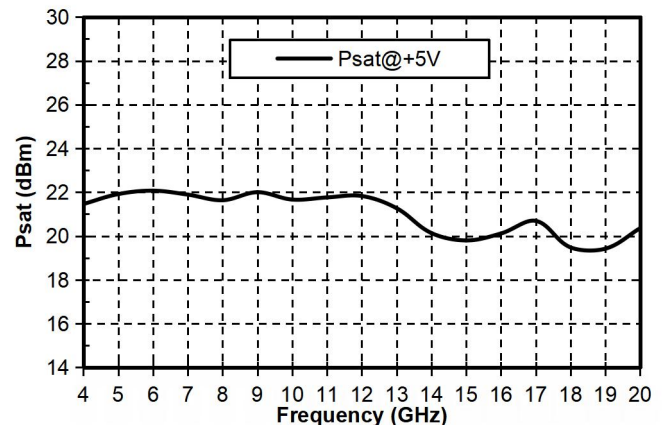

GaAs MMIC Power Amplifier Chip, 4 - 20 GHz

Appearance structure

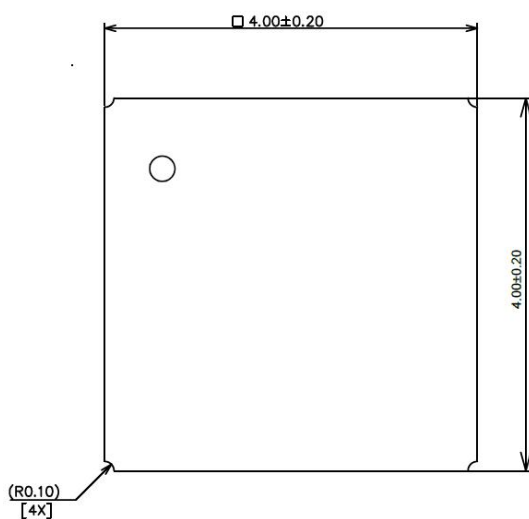

Top view

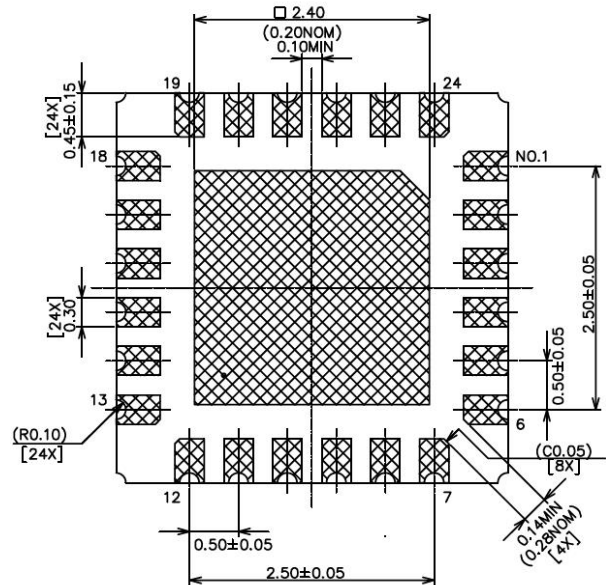

Bottom view

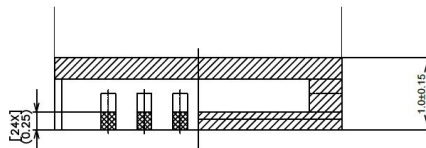

Side View

All units in the figures are millimeters .

Pin Definition		
Bonding point number	Function Symbol	Functional Description
3	RFIN	RF signal input terminal, no DC blocking capacitor required
16	RFOUT	RF signal output terminal, no DC blocking capacitor required
20, 21, 22	VDD	Amplifier Drain Bias
2, 4, 15, 17	GND	The bottom of the chip needs to be well grounded to RF and DC
1, 5~14, 18, 19, 23, 24	NC	No welding required, can be grounded

GaAs MMIC Power Amplifier Chip, 4 - 20 GHz

Recommended Circuit

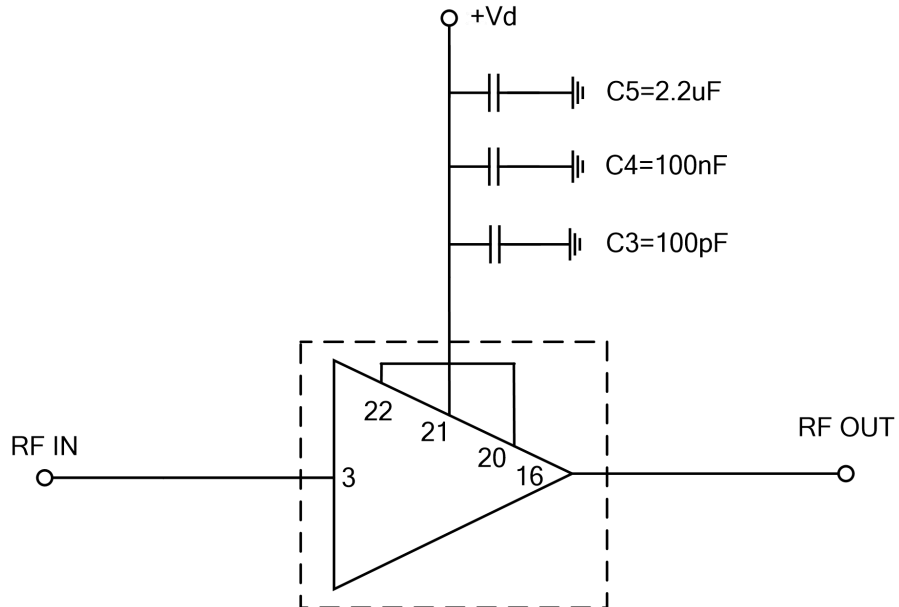

Raw material	Capacitance, inductance, resistance
C 3	100 pF
C 4	100nF
C 5	2.2uF

Precautions for use

- Sealing material : Ceramic material that meets ROHS standards
- Lead frame material: copper alloy
- Lead surface plating: gold, gold layer thickness greater than 1.3um
- Maximum reflow peak temperature: 260 °C