

GaAs MMIC Power Amplifier Chip, 4-8 GHz

Performance characteristics

- Frequency range: 4 - 8 GHz
- Small signal gain: 21dB
- Gain flatness: ± 1.5 dB
- P -1 dB : 28dBm
- Psat : 28.5dBm
- Power supply: +8 V /190mA
- 50Ohm input / output
- Chip size: QFN 5X5

Product Introduction

GPA-0408A-CQ5B is a broadband power amplifier based on GaAs technology , with a frequency range of 4GHz~8GHz. IPA-0408A-CQ5B supports +8V power supply. This chip adopts 5 x 5 mm ceramic surface mount package , and the surface of the pin pad is gold-plated, which is suitable for reflow soldering installation process.

Using the Limit Parameter

Maximum drain voltage	+10V
Maximum gate bias	-3V
Maximum input power	+20dBm
Operating temperature	-55 ~ + 125 °C
Storage temperature	-65 ~ +150°C

Exceeding any of these maximum limits may cause permanent damage.

Electrical performance parameters (TA = +25°C , Vd =+8V, Ids=190mA)

Index	Minimum	Typical Value	Maximum	Unit
Frequency Range	4-8			GHz
Small Signal Gain	-	21	-	dB
Gain Flatness		± 1.5		dB
P -1dB	-	28	-	dBm
Psat	-	28.5	-	dBm
Input return loss	-	12	-	dB
Output return loss	-	9	-	dB
Quiescent Current		190		mA

* By tuning the Vg terminal voltage from -2V to 0V , the recommended Vg terminal voltage is -0.7V .

GaAs MMIC Power Amplifier Chip, 4 - 8 GHz

Main index test curve

Gain vs. Frequency

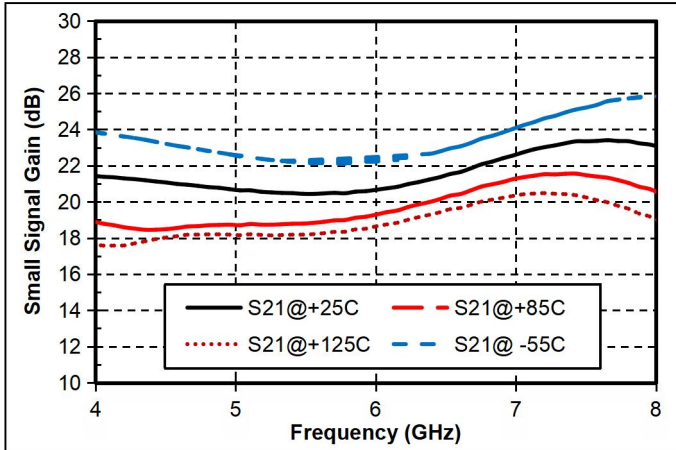

Reverse Isolation vs. Frequency

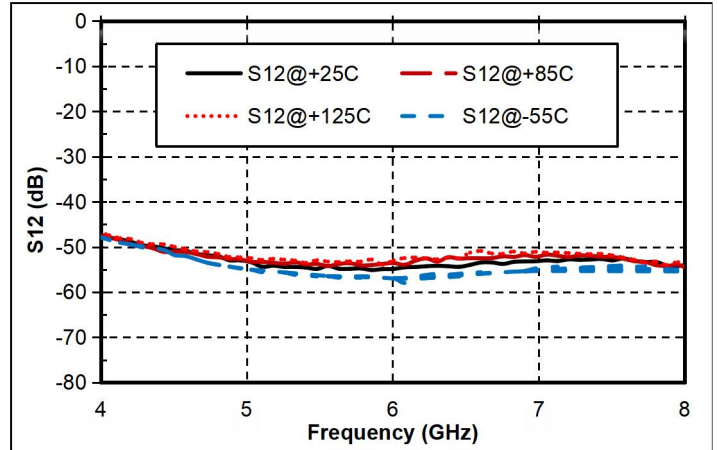

Input Return Loss vs. Frequency

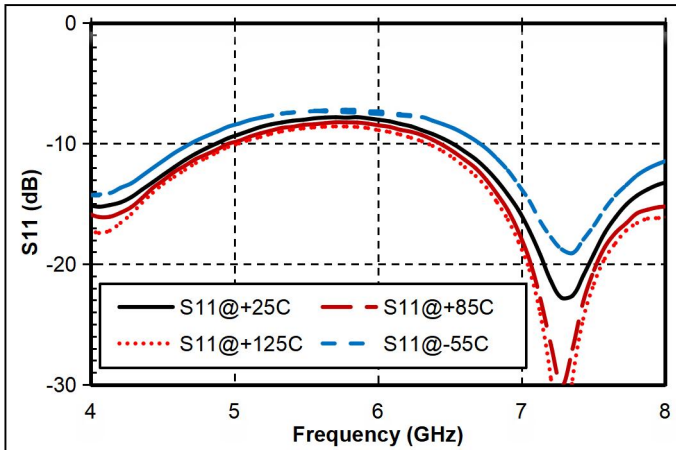

Output Return Loss vs. Frequency

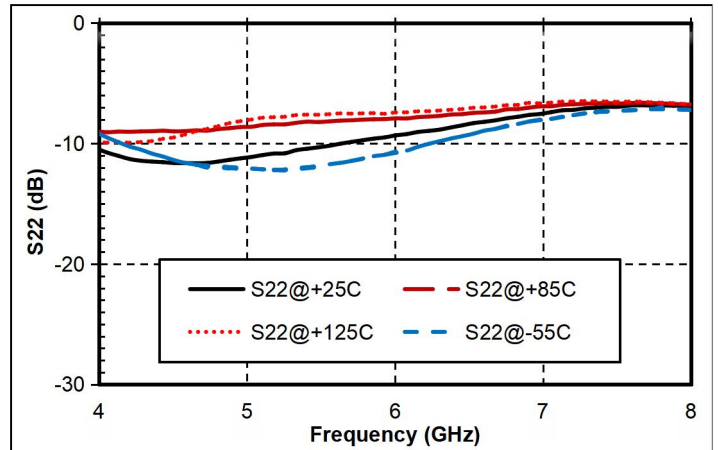

P-1dB vs. Frequency

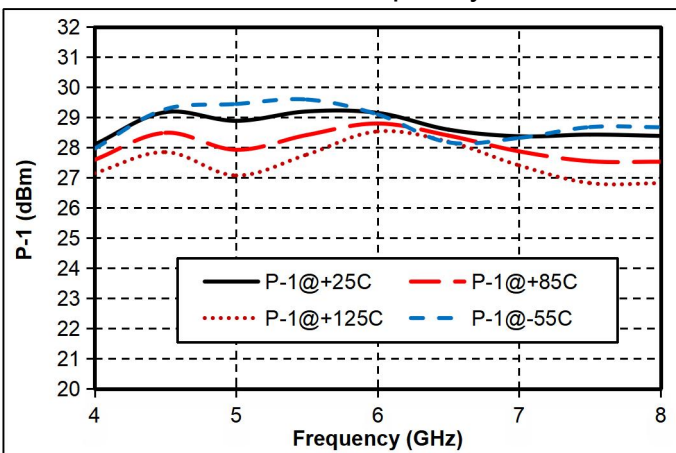

P sat vs. frequency

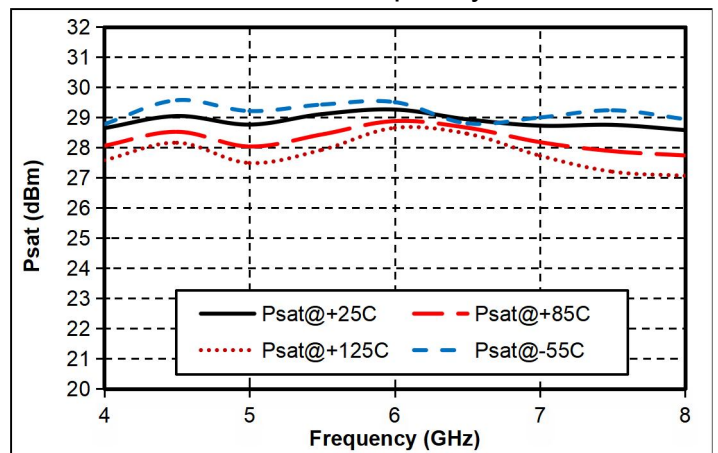

GaAs MMIC Power Amplifier Chip, 4 - 8 GHz

Appearance structure

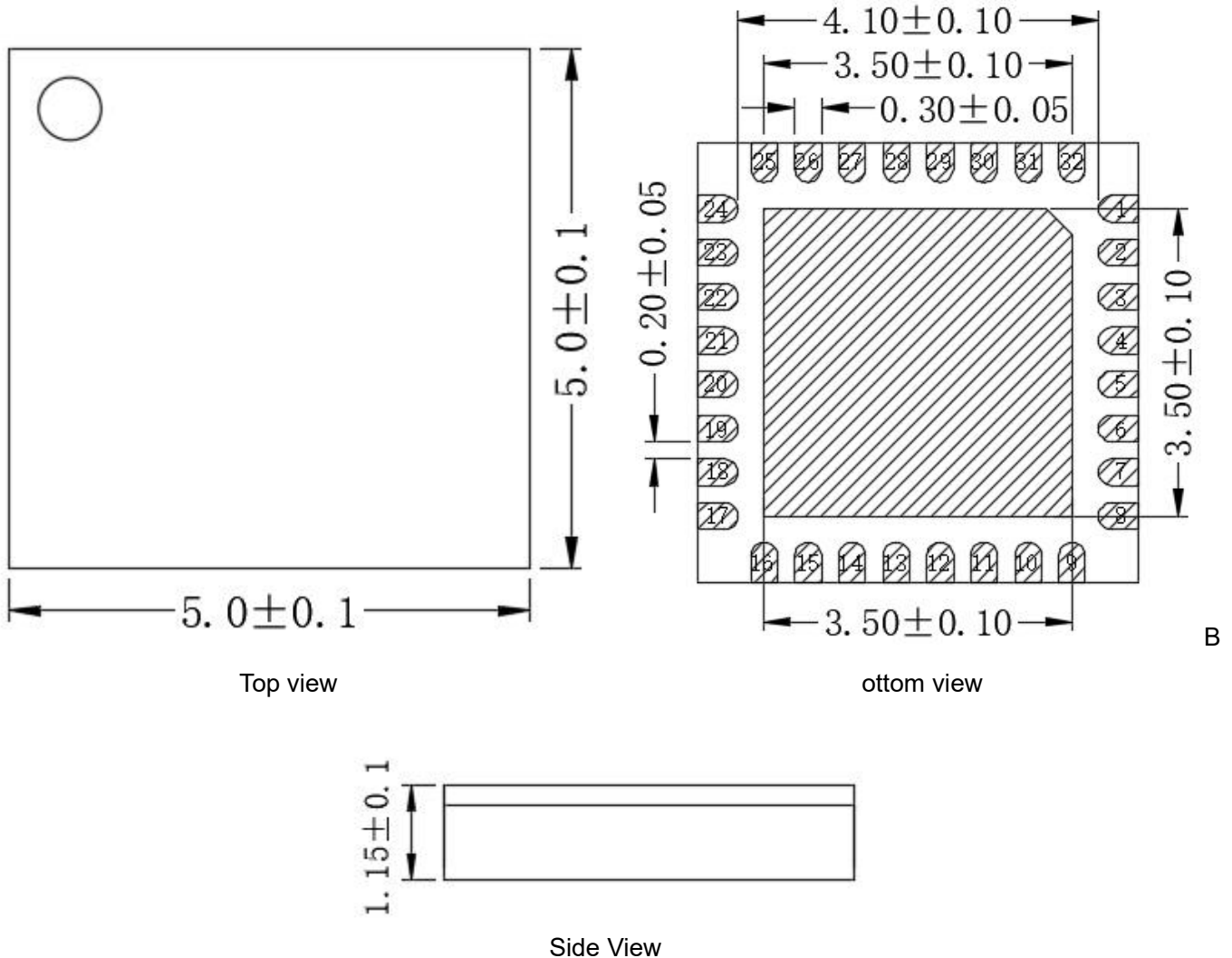

All units in the figures are millimeters .

Pin Definition		
Pin number	Function Symbol	Functional Description
4	RFIN	The signal input terminal is connected to a 50 ohm circuit, and no DC blocking capacitor is required
21	RFOUT	The signal output terminal is connected to a 50 ohm circuit, and no DC blocking capacitor is required
10 , 15	VG	Amplifier Gate Bias
2 6	VD	Amplifier Drain Bias
1-3 、 5-9 、 16-20 、 22-25 、 32	GND	The pins need to be well grounded to the RF and DC grounds

Chip bottom	GND	The bottom of the chip needs to be well grounded to RF and DC
Other	NC	No welding required, can be grounded

GaAs MMIC Power Amplifier Chip, 4 - 8 GHz

Recommended Circuit

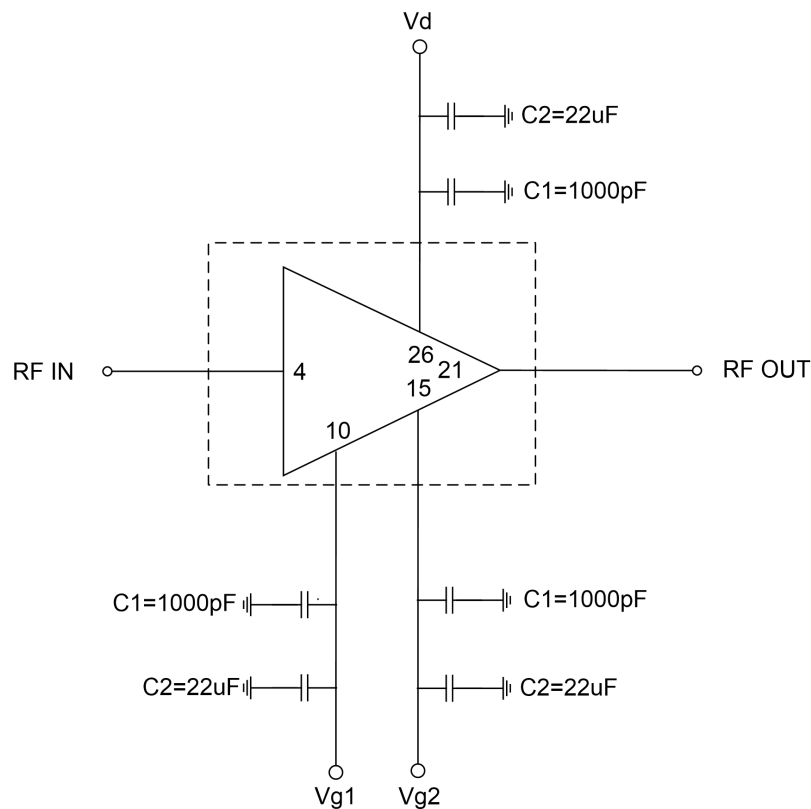

Precautions for use

- Sealing material : Ceramic material that meets ROHS standards
- Lead surface plating: gold, gold layer thickness 0.3um MIN
- Maximum reflow peak temperature: 260 °C