

GaAs MMIC Driver Amplifier Chip, 2 - 20 GHz

Performance characteristics

- Frequency range: 2 - 20 GHz
- Small signal gain: 18dB
- Gain flatness: ± 1.9 dB
- P -1 dB: 20.5 dBm
- Psat : 21.5dBm
- Power supply : + 5V/ 150mA
- 50Ohm input / output
- Chip size: QFN 3X3 mm

Functional Block Diagram

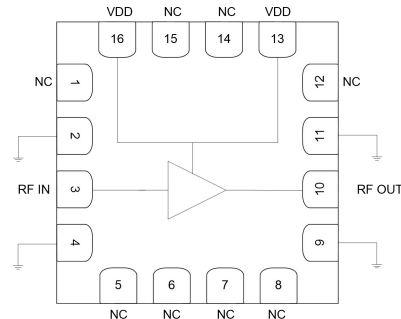

Product Introduction

GPA-0220-22-PQ3 is a GaAs driver amplifier with a frequency range of 2GHz~20GHz, a small signal gain of 18dB, and a P-1 output of 20.5dBm. GPA-0220-22-PQ3 is powered by a single +5V power supply. The amplifier is packaged in QFN3X3 plastic surface mount QFN package, and the surface of the pin pad is tinned, which is suitable for reflow soldering installation process.

Use restriction parameter ¹

Maximum drain voltage	+7V
Maximum input power	+20dBm
Operating temperature	-55 ~ + 125 °C
Storage temperature	-65 ~ +150°C

【1】 Exceeding any of these maximum limits may cause permanent damage.

Electrical performance parameters (TA =+25°C , Vd=+5V)

Index	Minimum	Typical Value	Maximum	Unit
Frequency Range	2-20			GHz
Small Signal Gain @ 1GHz	-	18	-	dB
Gain Flatness	-	± 1.9	-	dB
Input return loss	-	17	-	dB
Output return loss	-	15	-	dB
Reverse Isolation	-	50	-	dB
P -1 dB	-	20.5	-	dBm
Psat	-	21.5	-	dBm
Quiescent Current	-	150	-	mA

GaAs MMIC Driver Amplifier Chip, 2 - 20 GHz

Main index test curve

Gain vs. Frequency

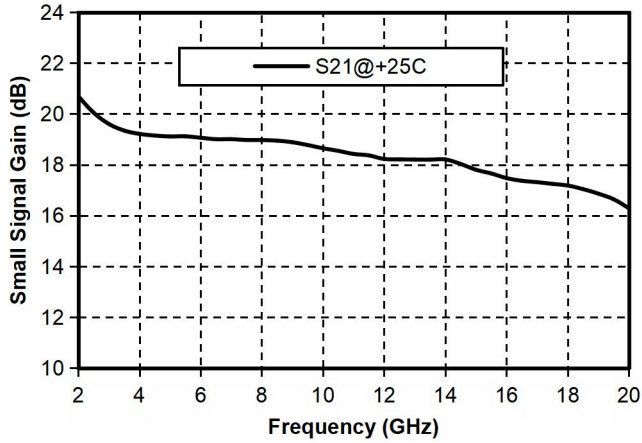

Reverse Isolation vs. Frequency

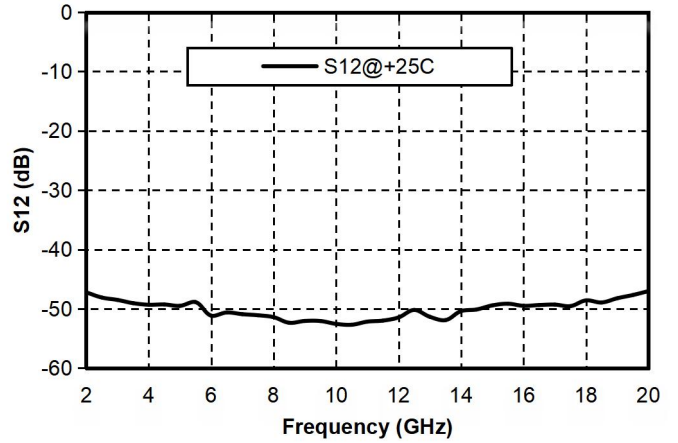

Input Return Loss vs. Frequency

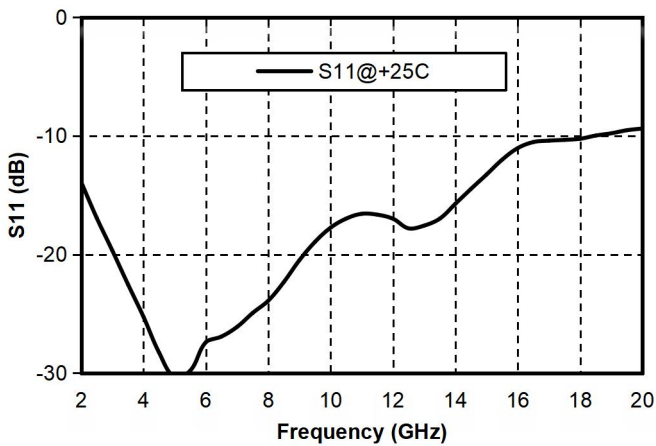

Output Return Loss vs. Frequency

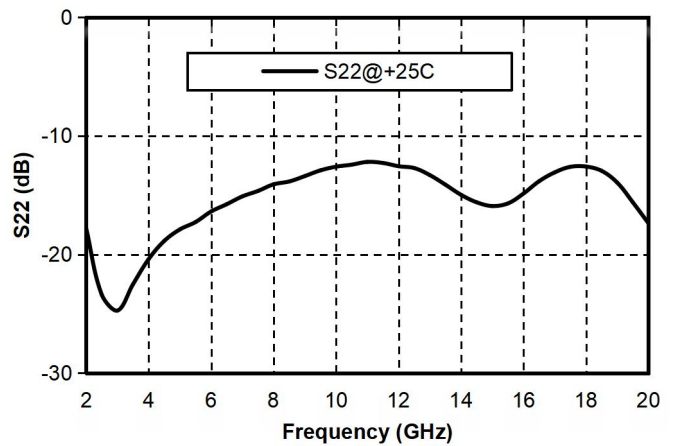

P-1dB vs. Frequency

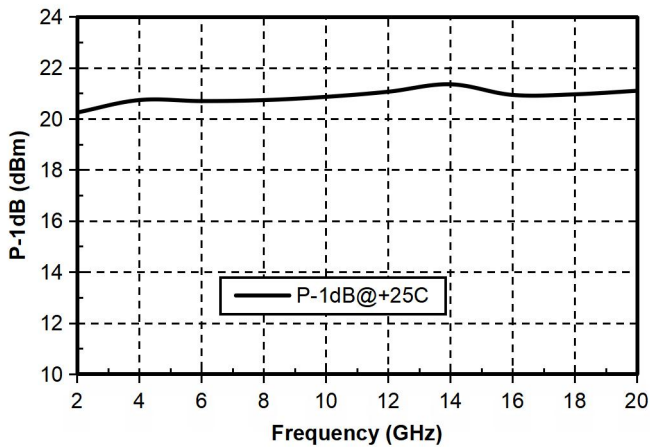

P sat vs. frequency

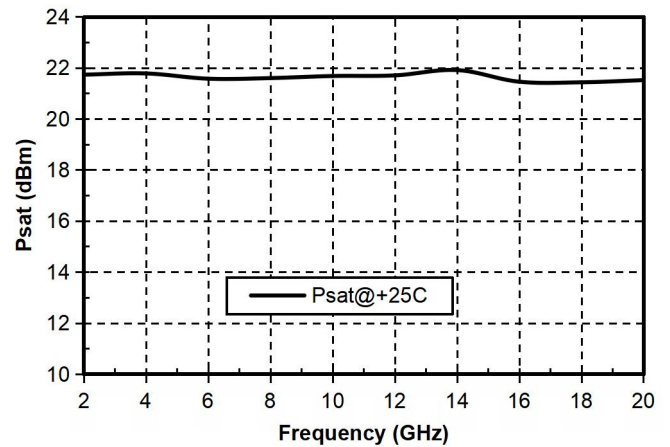

GaAs MMIC Driver Amplifier Chip, 2 - 20 GHz

Appearance structure

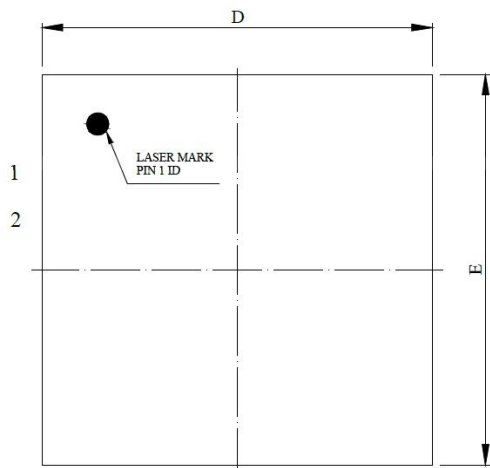

Top view

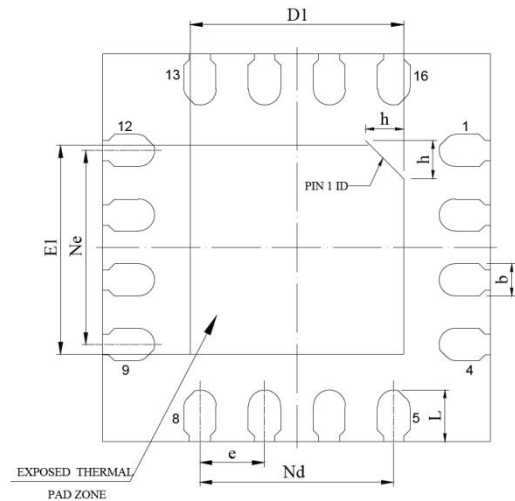

Bottom view

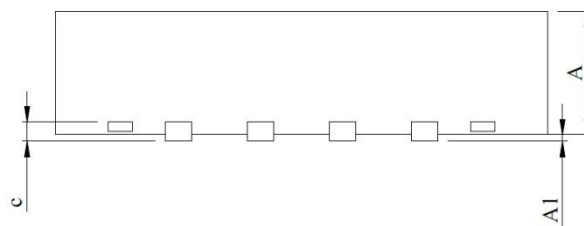

Side View

All units in the figures are millimeters .

Structure size

Annotation	Minimum	Standard	Maximum	Annotation	Minimum	Standard	Maximum
A	0.70	0.75	0.80	N_e	1.50BSC		
A1	-	0.02	0.05	N_d	1.50BSC		
b	0.20	0.25	0.30	E	2.9	3.0	3.1
c	0.203REF			E1	1.6	1.7	1.8
D	2.90	3.00	3.10	L	0.35	0.40	0.45
D1	1.6	1.7	1.8	h	0.25	0.30	0.35
e	0.50BSC						

All units in the figures are millimeters .

GaAs MMIC Driver Amplifier Chip, 2 - 20 GHz

Pin Definition		
Bonding point number	Function Symbol	Functional Description
3	RF IN	RF signal input terminal, no external DC blocking capacitor required
10	RFOUT	RF signal output terminal, no external DC blocking capacitor required
2, 4, 9, 11	GND	Grounding
13, 16	VDD	Amplifier Drain Bias
Back lot	GND	The bottom of the chip needs to be well grounded to RF and DC
1, 5-8, 12, 14, 15	NC	The pin is left floating and can be grounded

Recommended bias circuit

