

GaAs MMIC Power Amplifier Chip, 2-6 GHz

Performance characteristics

- Frequency range: 2 - 6 GHz
- Small signal gain: 23dB
- Gain flatness: ± 0.75 dB
- P -1 dB : 23.5dBm
- Psat : 24.5dBm
- Power supply: +5 V /200mA
- 50Ohm input / output
- Chip size: QFN 5X5

Functional Block Diagram

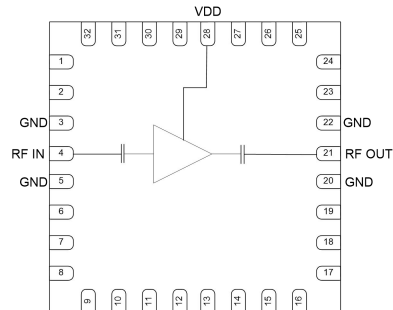

Product Introduction

GPA-0206A-CQ5 is a broadband amplifier based on GaAs technology , with a frequency range of 2GHz~6GHz, a small signal gain of 23dB, and a P-1 output of 23.5dBm. GPA-0206A-CQ5 is powered by a single +5V power supply. This chip uses a 5 x 5 mm ceramic surface mount package, which can achieve airtight packaging. The surface of the pin pad is gold-plated, which is suitable for reflow soldering installation process.

Use limit parameters

Maximum drain voltage	+7V
Maximum input power	+20dBm
Operating temperature	-55 ~ +85°C
Storage temperature	-65 ~ +150°C

Exceeding any of these maximum limits may cause permanent damage.

Electrical performance parameters (TA = +25°C , Vd = +5V)

Index	Minimum	Typical Value	Maximum	Unit
Frequency Range	2-6			G Hz
Small Signal Gain	-	23	-	dB
Gain Flatness	-	± 0.75	-	dB
P -1dB	-	23.5	-	dBm
Psat	-	24.5	-	dBm
Input return loss	-	15	-	dB
Output return loss	-	10	-	dB
Quiescent Current		200		mA

GaAs MMIC Power Amplifier Chip, 2 - 6 GHz

Main index test curve

Gain vs. Frequency

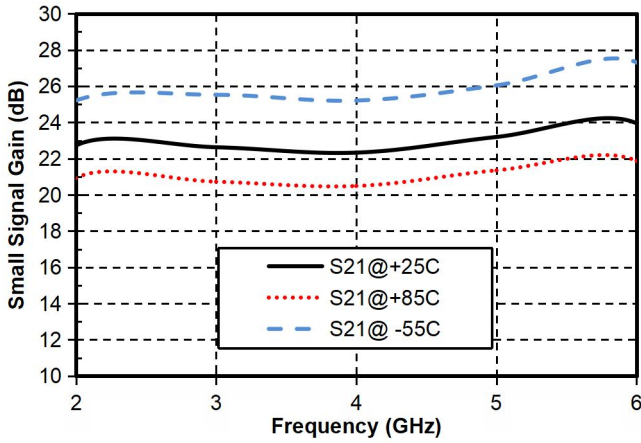

Reverse Isolation vs. Frequency

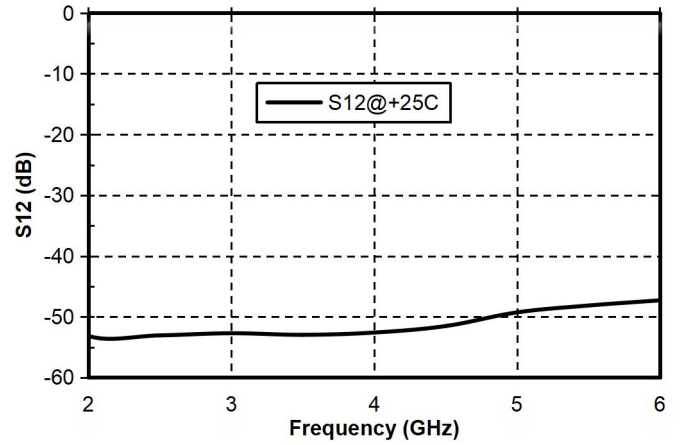

Input Return Loss vs. Frequency

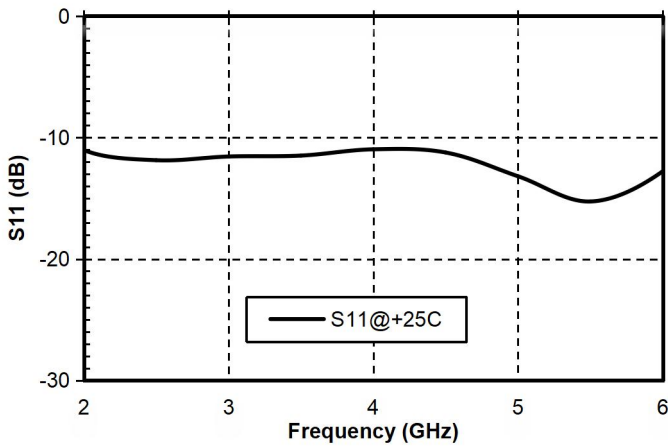

Output Return Loss vs. Frequency

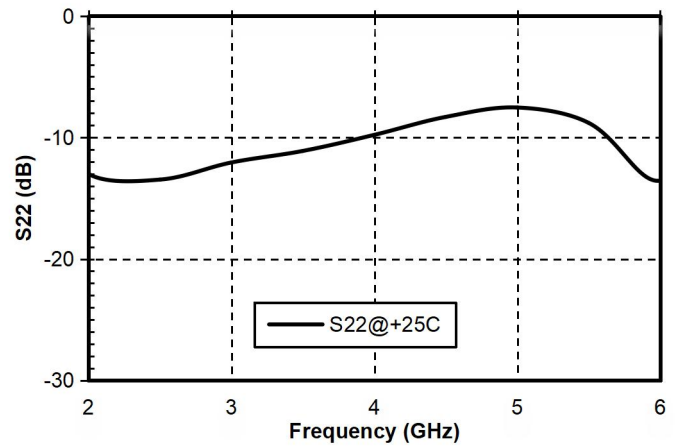

P-1dB vs. Frequency

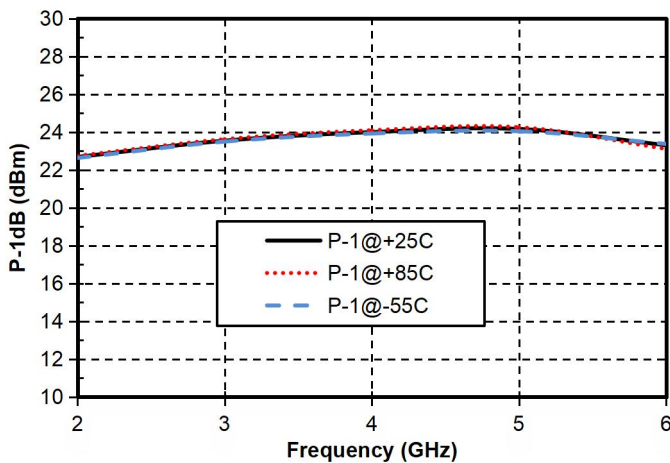

P sat vs. frequency

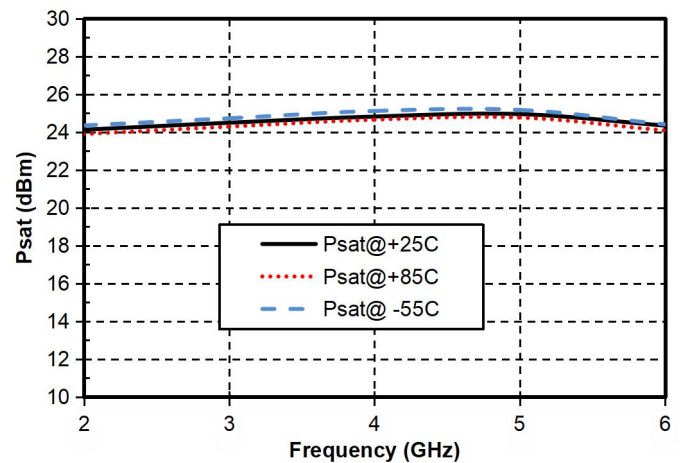

GaAs MMIC Power Amplifier Chip, 2 - 6 GHz

Appearance structure

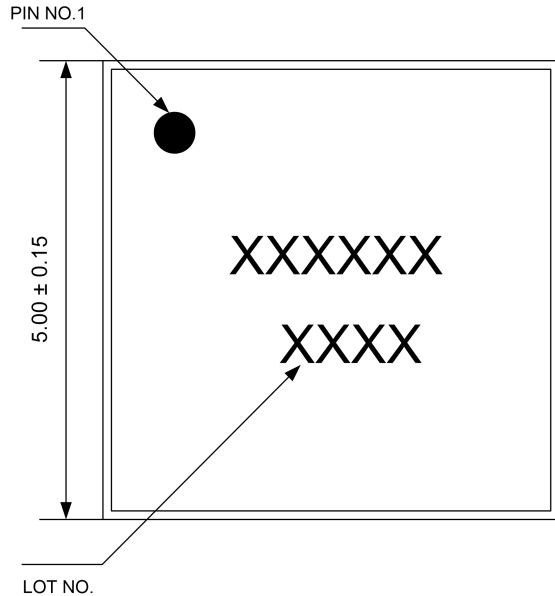

Top view

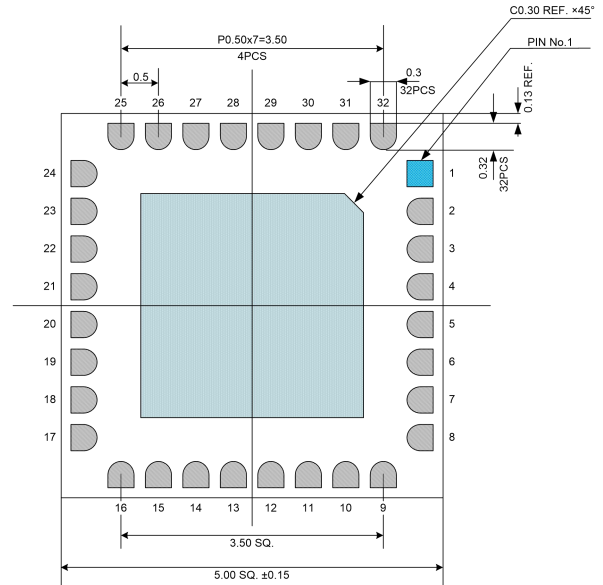

Bottom view

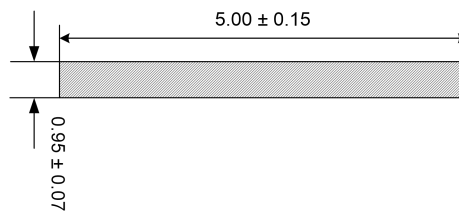

Side View

All units in the figures are millimeters .

Pin Definition		
Pin Definition	Function Symbol	Functional Description
4	RFIN	RF signal input terminal, no DC blocking capacitor required
21	RFOUT	RF signal output terminal, no DC blocking capacitor required
28	Vd	Amplifier drain bias , requires external bypass capacitor
3, 5, 20, 22	GND	The bottom of the chip needs to be well grounded to RF and DC

Other	NC	Floating pin, can be grounded
-------	----	-------------------------------

GaAs MMIC Power Amplifier Chip, 2 - 6 GHz

Recommended Circuit

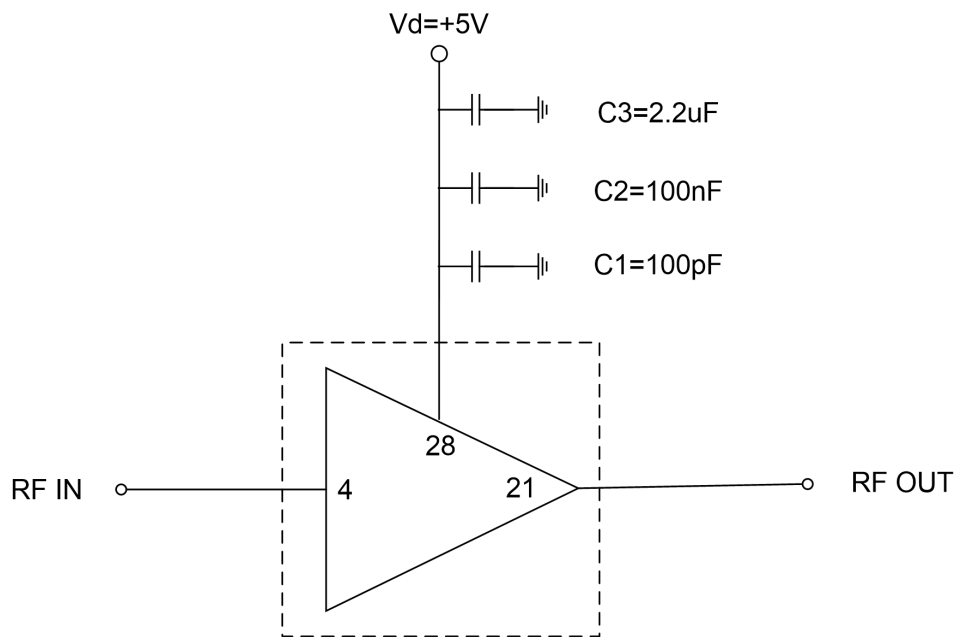

Precautions for use

- Sealing material : Ceramic material that meets ROHS standards
- Lead frame material: copper alloy
- Lead surface plating: gold, gold layer thickness 0.3um MIN
- Maximum reflow peak temperature: 260 °C