

## GaAs MMIC Power Amplifier Chip, DC- 10 GHz

### Performance characteristics

Frequency range: DC - 10 GHz  
 Small signal gain: 18.5dB  
 Gain flatness:  $\pm 1.2$ dB  
 P-1dB: 26 dBm  
 Psat : 27 dBm  
 Power supply: + 8V / 300mA  
 50Ohm input / output  
 Chip size: QFN 5X5

### Functional Block Diagram

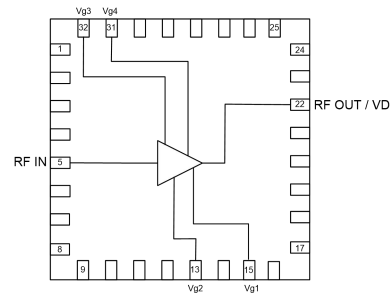

### Product Introduction

GPA- 0010A-CQ5 is an ultra-wideband distributed amplifier chip based on pHEMT technology, with a frequency range of DC~ 10 GHz, a small signal gain of 18.5 dB, and a saturated output power of 27 dBm . This chip uses a 5 x 5 mm ceramic surface mount package to achieve airtight packaging. The surface of the pin pad is gold-plated and is suitable for reflow soldering installation.

### Use restriction parameter <sup>1</sup>

Maximum drain voltage	+1.2 V
Maximum gate bias	-3V
Maximum input power	+20dBm
Operating temperature	-55 ~ +85°C
Storage temperature	-65 ~ +150°C

**【1】** Exceeding any of these maximum limits may cause permanent damage.

### Electrical parameters (Ta=+25°C, Vd = + 8V, Ids= 300 mA)

Index	Minimum	Typical Value	Maximum	Unit
Frequency Range	DC-10			GHz
Small Signal Gain	-	18.5	-	dB
Gain Flatness	-	$\pm 1.2$	-	dB
P-1dB	-	26	-	dBm
Psat	-	27	-	dBm
Input return loss	-	23	-	dB
Output return loss	-	18	-	dB

\*By tuning the Vg 1 terminal voltage from -2V to 0V, 300 mA is achieved and the Vg terminal voltage is expected to be -0.6 V.

## GaAs MMIC Power Amplifier Chip, DC- 10 GHz

Main index test curve

Gain vs. Temperature

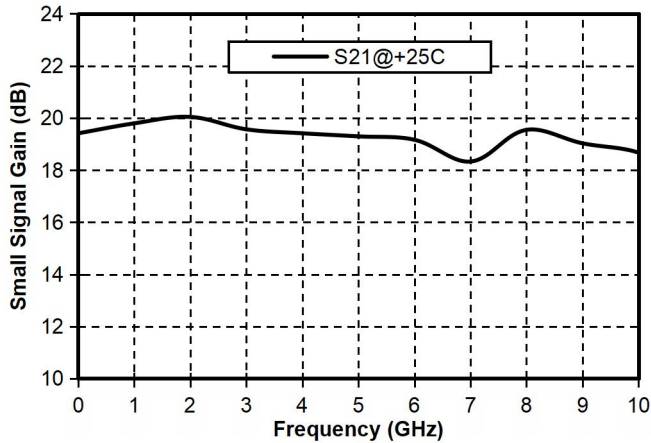

Reverse Isolation vs. Frequency

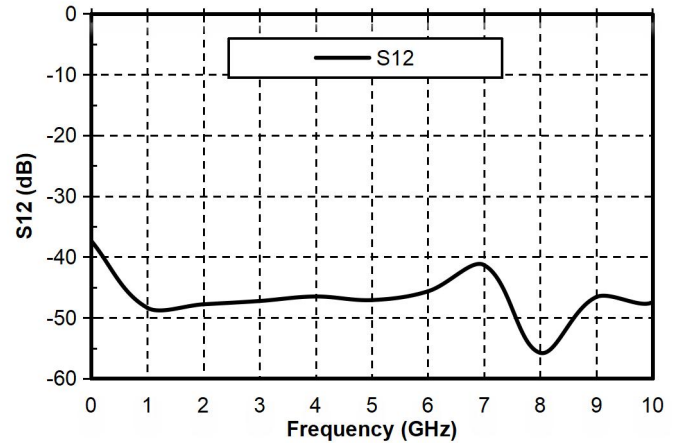

Input Return Loss vs. Frequency

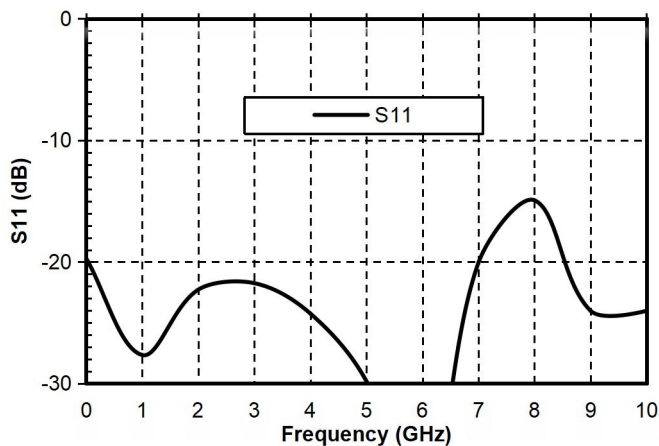

Output Return Loss vs. Frequency

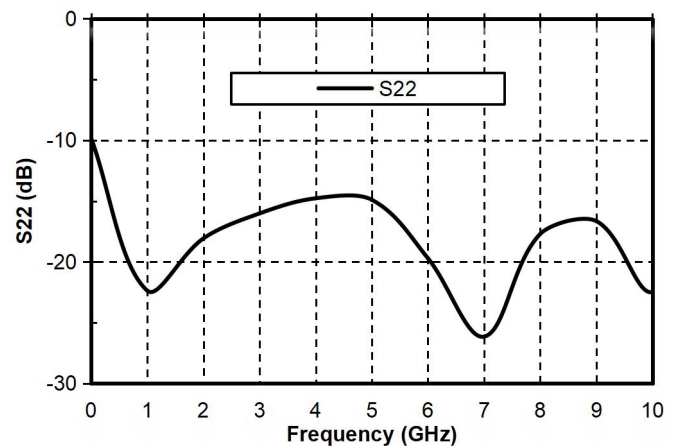

P-1dB vs. Frequency

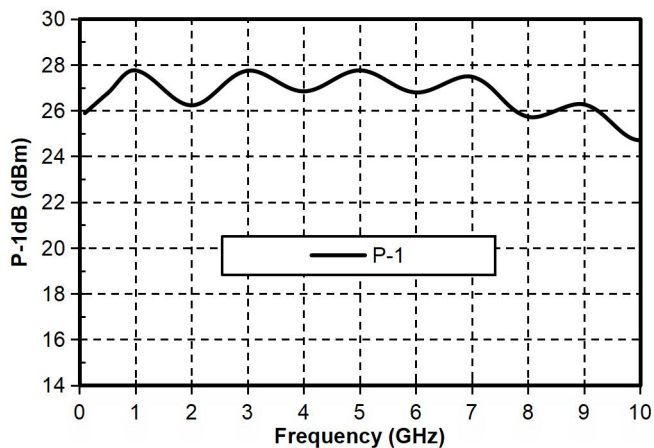

Psat vs. Frequency

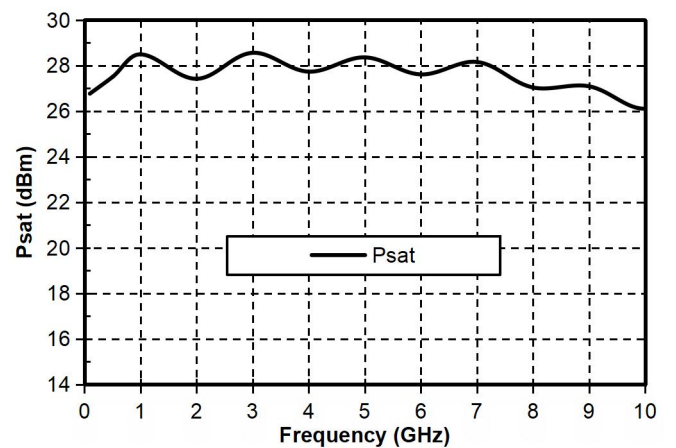

## GaAs MMIC Power Amplifier Chip, DC- 10 GHz

### Appearance structure

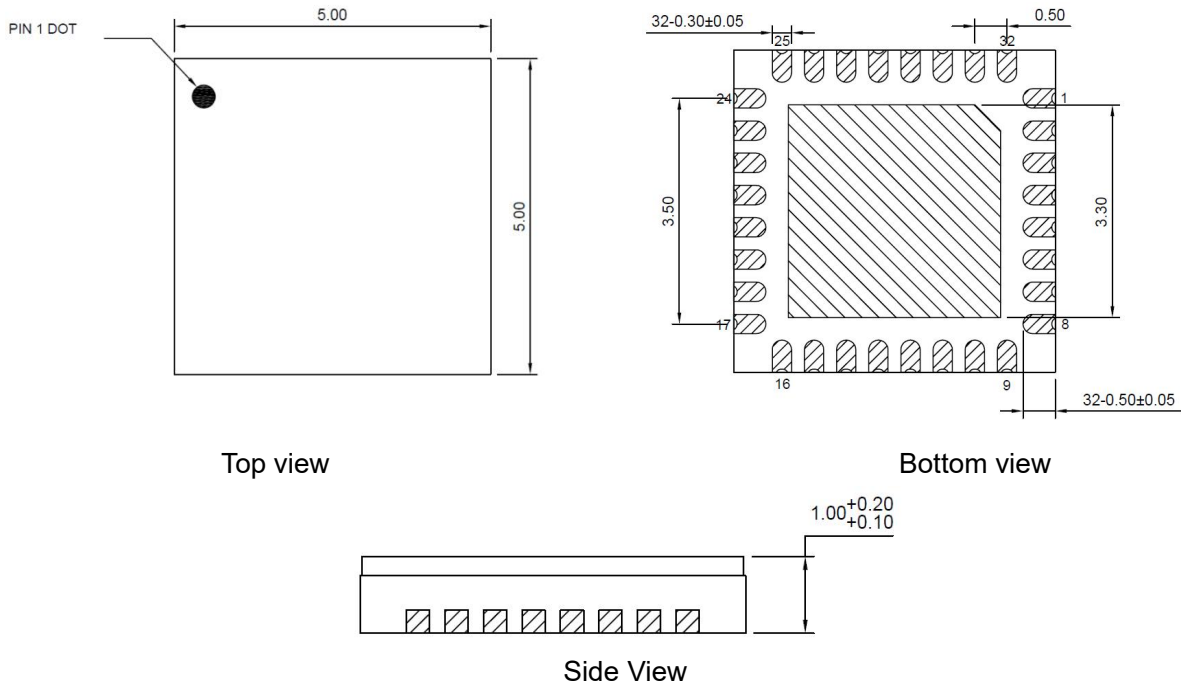

The units in the figures are all in millimeters , and the tolerance is  $\pm 0.15$  mm.

Pin Definition		
Bonding point number	Function Symbol	Functional Description
5	RFIN	The signal input terminal is connected to a 50 ohm circuit, and a DC blocking capacitor needs to be added
22	RFOUT	The signal output terminal is connected to a 50 ohm circuit, and a DC blocking capacitor needs to be added . An external DC bias network is connected to provide drain current.
13, 15, 31, 32	Vg 1~Vg4	Amplifier gate bias, requires external bypass capacitor
4, 6, 21, 23	GND	The bottom of the chip needs to be well grounded to RF and DC
Other	NC	Floating pin, can be grounded

## GaAs MMIC Power Amplifier Chip, DC- 10 GHz

### Recommended Circuit

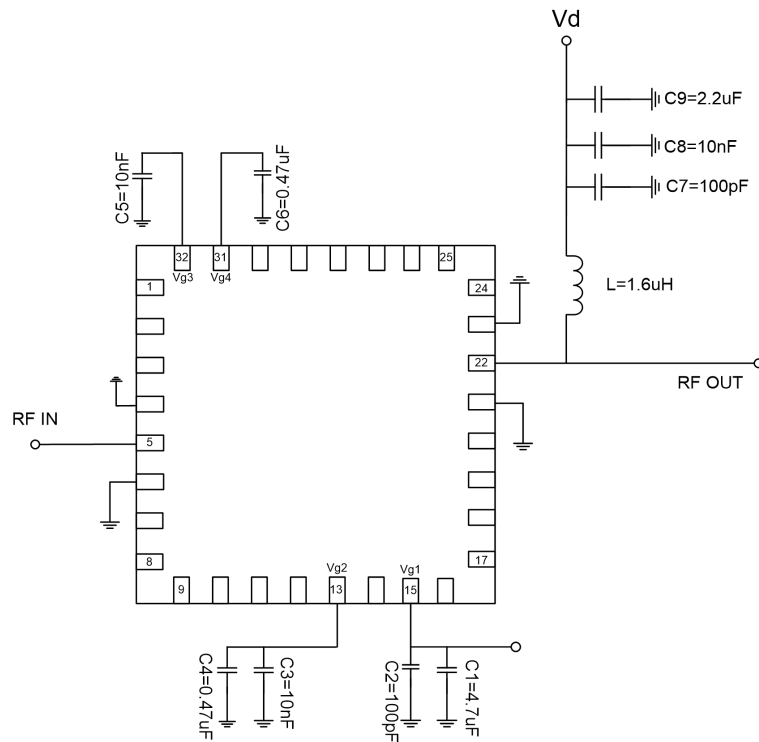

### Precautions for use

- Sealing material : Ceramic material that meets ROHS standards
- Lead frame material: copper alloy
- Lead surface plating: gold, gold layer thickness greater than 1.3um
- Maximum reflow peak temperature: 260 °C