

GaAs MMIC Mixer Chip, 24GHz-38GHz

Performance characteristics

- RF/LO frequency range: 24 - 38 GHz
- IF frequency range : DC-18GHz
- Conversion loss : 7 dB@+13dBm LO input
- LO-RF isolation: 37dB
- LO-IF isolation : 42dB
- RF-IF isolation : 42 dB
- Local oscillator power: +11dBm~+15dBm
- Chip size: 1.4 x 1.15 x 0.1mm

Block Diagram

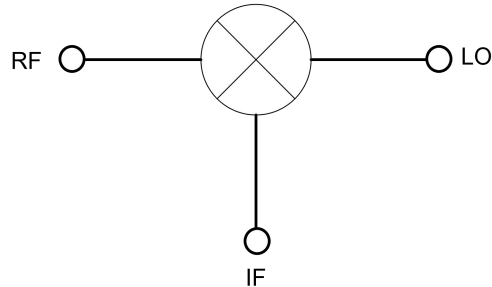

Product Introduction

GMX-2438A is a GaAs MMIC double balanced mixer, covering 24 GHz~ 38 GHz , IF frequency coverage DC~ 18 GHz , conversion loss 7 dB , LO/RF isolation 37d B , LO/IF isolation 42 dB , RF/IF isolation 42 dB , typical LO input power +13dBm. The chip uses on-chip through-hole metallization technology to ensure good grounding, and no additional grounding measures are required. Easy to use. The back of the chip is metallized, suitable for eutectic sintering or conductive adhesive bonding. There is no DC blocking capacitor at the RF , LO, and IF ports .

Use restriction parameter ¹

Maximum RF input power	+22dBm
Maximum LO input power	+22dBm
Maximum IF input power	+22dBm
Operating temperature	-55 ~ +85°C
storage temperature	-65 ~ +150°C

【1】 Exceeding any of these maximum limits may cause permanent damage.

Electrical performance parameters ($T_A = +25^\circ\text{C}$, IF = 100MHz , LO = +13 dBm)

index	Minimum	Typical Value	Maximum	unit
RF frequency range	24-38			GHz
LO frequency range	24-38			GHz
IF frequency	DC-18			GHz
Frequency conversion loss	-	7	-	dB
LO-RF Isolation	-	37	-	dB
LO-IF isolation	-	42	-	dB
RF-IF isolation	-	42	-	dB
RF input P-1dB	11			dB m
IIP3	17			dBm

The above parameters are all tested in down-conversion mode, with an intermediate frequency of 0.1GHz and a local oscillator power of + 13dBm.

GaAs MMIC Mixer Chip, 24GHz-38GHz

Main index test curve

Downconversion loss vs. temperature @ LO = +13dBm

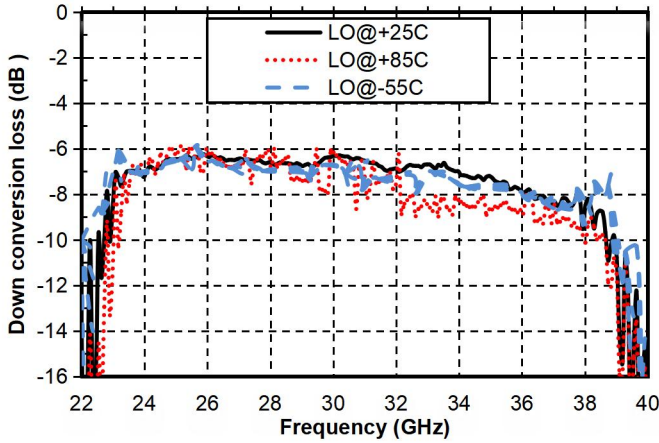

Downconversion Loss vs. LO Power

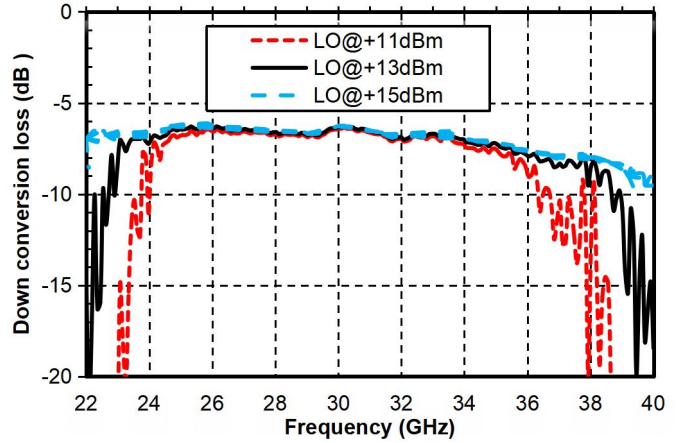

Isolation @ LO = +13dBm

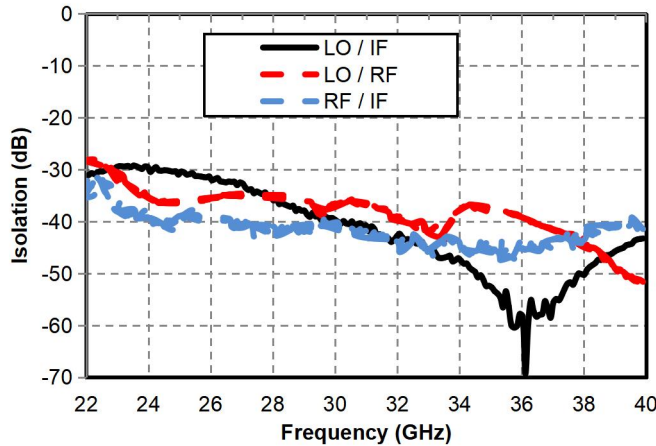

RF Return Loss Vs. Frequency

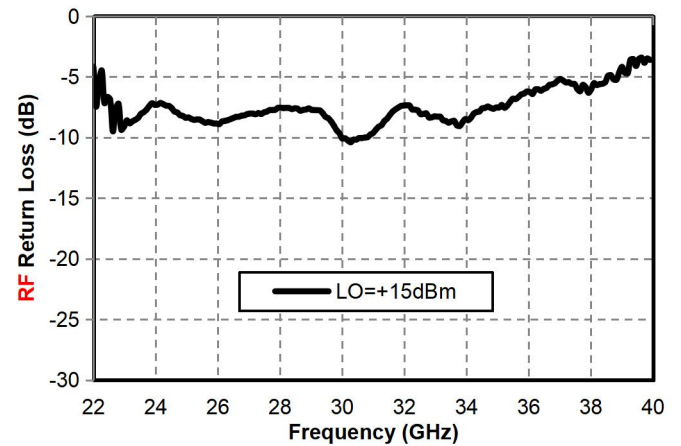

LO Return Loss Vs. Frequency

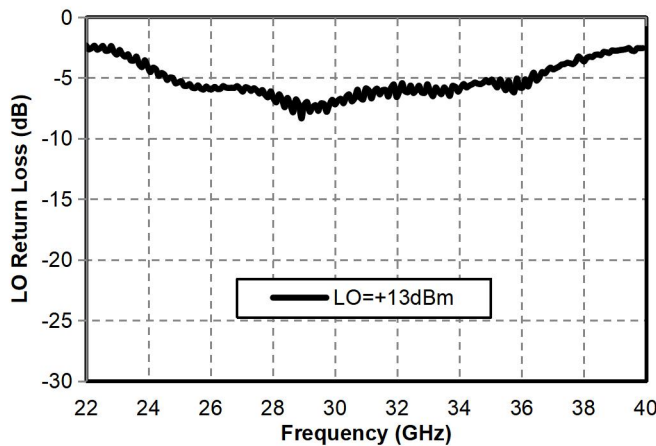

Upconversion Loss vs. LO Power

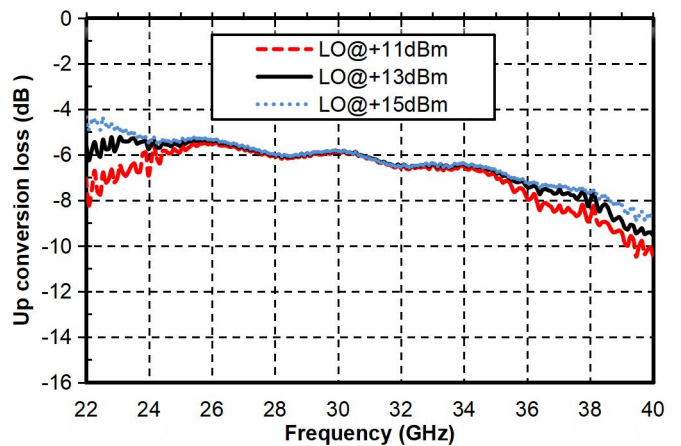

GaAs MMIC Mixer Chip, 24GHz-38GHz

Down -conversion IF bandwidth, return loss
@LO=24G, 13dBm

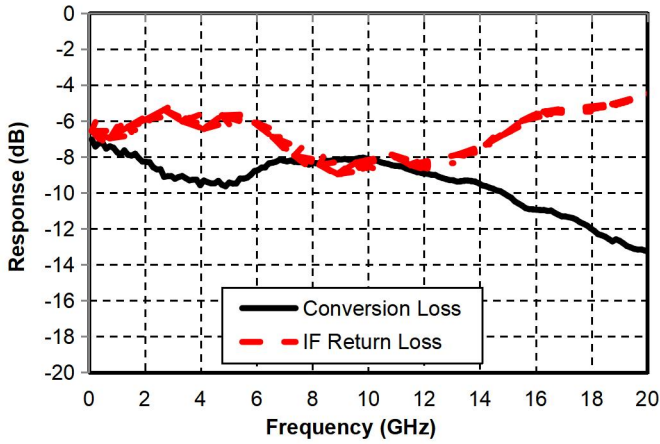

IIP3

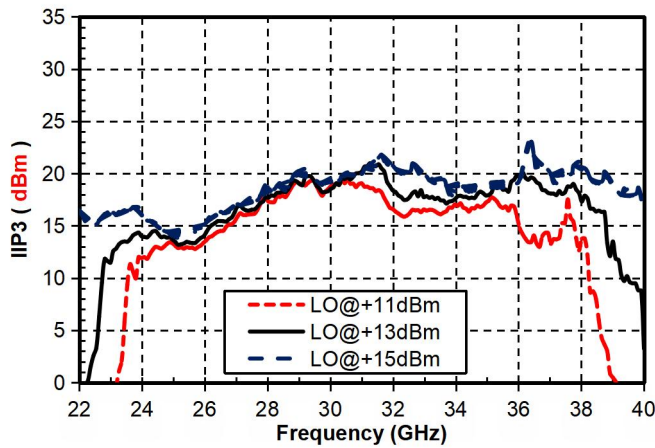

Down-conversion IF bandwidth, return loss
@LO=38G, 13dBm

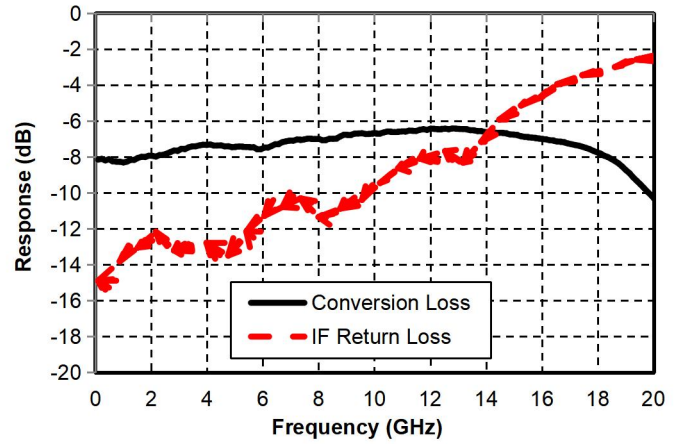

P-1 vs. Frequency

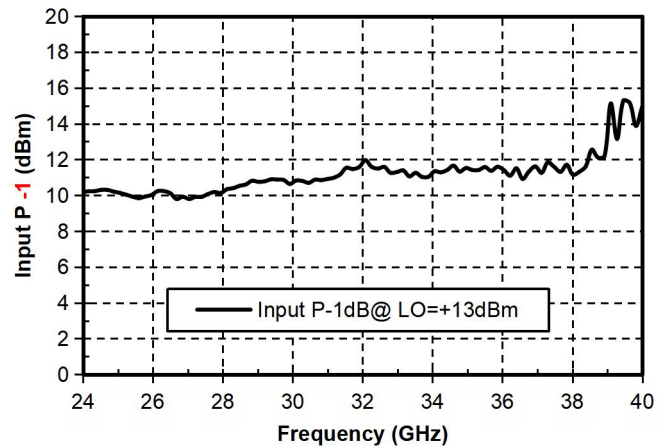

LO harmonic leakage

LO(GHz) 1 3 dBm	nLO (measured at RF port) dBc		
	1	2	3
twenty four	34	42	/
26	35	/	/
28	36	/	/
30	37	/	/
32	40	/	/
34	39	/	/
36	39	/	/
38	42	/	/

GaAs MMIC Mixer Chip, 24GHz-38GHz

Down-conversion combined spurious suppression

mRF	nLO				
	0	1	2	3	4
0	xxx	1	/	/	/
1	35	0	43	/	/
2	/	49	50	46	/
3	/	/	81	54	79
4	/	/	/	90	87

Test conditions: RF=26.1GHz@-10dBm, LO=26GHz@13dBm, all values are relative values of 1*RF-1*LO(P_IF,dBm), unit: dBc .

mRF	nLO				
	0	1	2	3	4
0	xxx	12	/	/	/
1	35	0	38	/	/
2	/	63	58	49	/
3	/	/	85	64	/
4	/	/	/	99	102

Test conditions: RF=31.1GHz@-10dBm, LO=31GHz@13dBm, all values are relative values of 1*RF-1*LO(P_IF,dBm), unit: dBc .

Up-conversion combined spurious suppression

iF	nLO				
	0	1	2	3	4
0	xxx	-3	1	/	/
1	36	0	27	/	/
2	47	84	36	/	/
3	67	75	68	54	/
4	75	88	96	82	/

Test conditions: RF=10.3GHz@-10dBm, LO=25GHz@13dBm, all values are relative values of 1* LO -1* IF (P_RF , dBm), unit: dBc .

iF	nLO				
	0	1	2	3	4
0	xxx	0	/	/	/
1	26	0	33	/	/
2	47	/	59	/	/
3	82	68	81	66	/
4	/	95	/	/	/

Test conditions: RF=14.3GHz@-10dBm, LO=30GHz@13 dBm, all values are relative values of 1* LO -1* IF (P_ R F,dBm), unit: dBc .

GaAs MMIC Mixer Chip, 24GHz-38GHz

Appearance structure ²

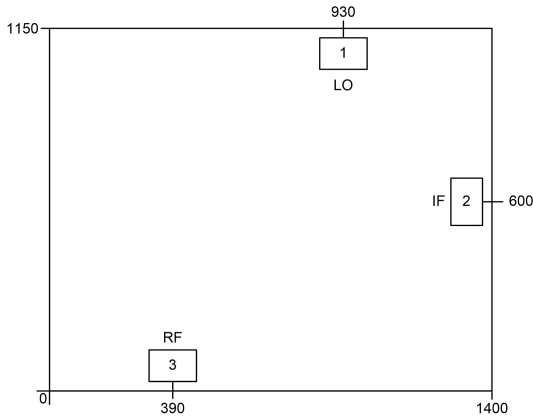

【2】 The units in the figure are all micrometers (dimensional tolerance: $\pm 50\mu\text{m}$.)

Recommended assembly drawing

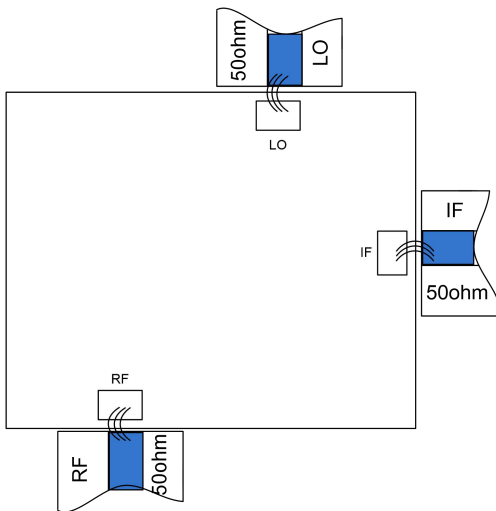

Bonding point definition

Bonding point number	Function Symbol	Functional Description
1	LO	The local oscillator signal terminal requires an external DC blocking capacitor
2	IF	Intermediate frequency signal end, requires external DC blocking capacitor
3	RF	RF signal end, requires external DC blocking capacitor
Chip bottom	GND	The bottom of the chip needs to be well grounded to RF and DC

Note 1: LO and RF ports can be used interchangeably, but the electrical performance indicators may vary.

Note 2: It is recommended to solder three gold bonding wires to the pad.