

## GaAs MMIC Mixer Chip, 3GHz-12GHz

### Performance characteristics

- RF/LO frequency range: 3 - 12 GHz
- IF frequency range : DC-4GHz
- Conversion loss : 9.5 dB@+15dBm LO input
- LO-RF isolation: 57dB
- LO-IF isolation : 38dB
- RF-IF isolation : 49 dB
- Local oscillator power: +13dBm~+17dBm
- Chip size: 1.73 x 1.23 x 0.1mm

### Block Diagram

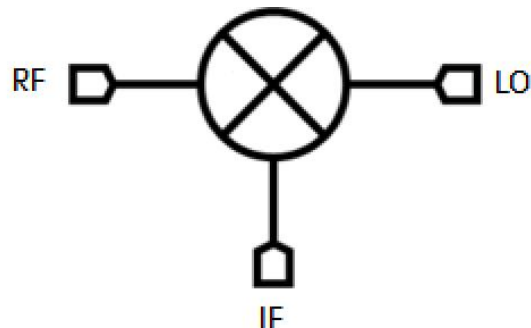

### Product Introduction

GMX-0312A is a GaAs MMIC double-balanced mixer with a frequency range of 3 GHz to 12 GHz , an IF range of DC to 4 GHz , a conversion loss of 9.5 dB , a LO/RF isolation of 57 dB , a LO /IF isolation of 38 dB , an RF/ IF isolation of 49 dB , and a typical LO input power of +15 dBm. The chip uses an on-chip through-hole metallization process to ensure good grounding, and no additional grounding measures are required. Easy to use. The back of the chip is metallized, suitable for eutectic sintering or conductive adhesive bonding. There is no DC blocking capacitor at the RF , LO, and IF ports .

### Use restriction parameter <sup>1</sup>

Maximum RF input power	+22dBm
Maximum LO input power	+22dBm
Maximum IF input power	+22dBm
Operating temperature	-55 ~ +85°C
storage temperature	-65 ~ +150°C

【1】 Exceeding any of these maximum limits may cause permanent damage.

### Electrical performance parameters ( $T_A = +25^\circ\text{C}$ , IF = 100MHz , LO = + 15dBm )

index	Minimum	Typical Value	Maximum	unit
RF frequency range	3-12			GHz
LO frequency range	3-12			GHz
IF frequency	DC-4			GHz
Frequency conversion loss	-	9.5	-	dB
LO-RF Isolation	-	57	-	dB
LO-IF isolation	-	38	-	dB
RF-IF isolation	-	49	-	dB
RF input P-1dB		13.5		dB m
IIP3		19		dBm

The above parameters are all tested in down-conversion mode, with an intermediate frequency of 0.1GHz and a local oscillator power of + 15dBm.

## GaAs MMIC Mixer Chip, 3GHz-12GHz

### Main index test curve

Downconversion loss vs. temperature @ LO = +15dBm

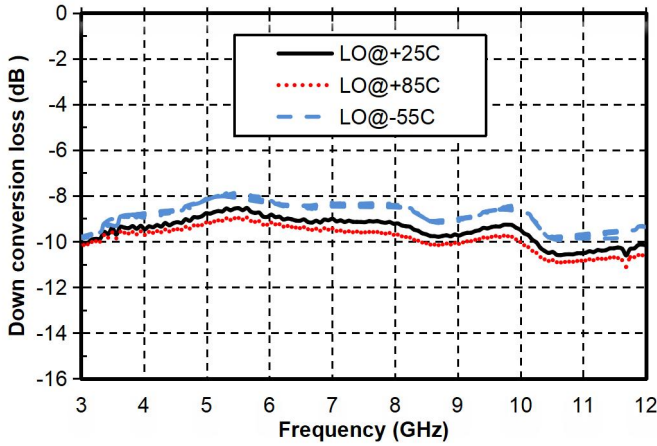

Downconversion Loss vs. LO Power

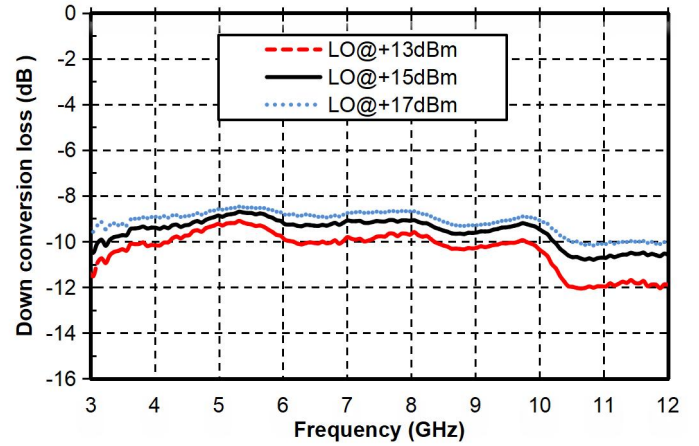

Isolation @ LO = +15dBm

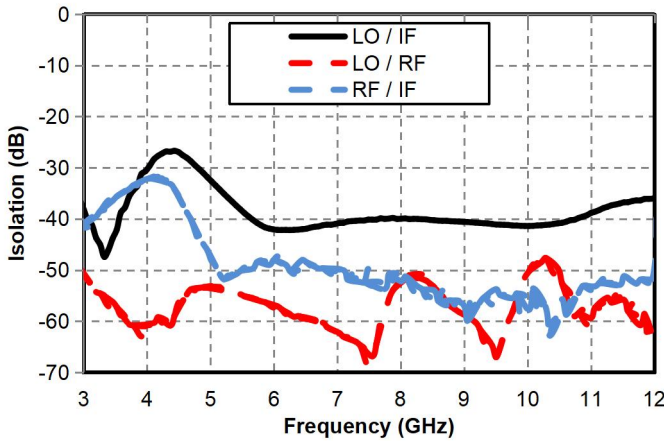

RF Return Loss Vs. Frequency

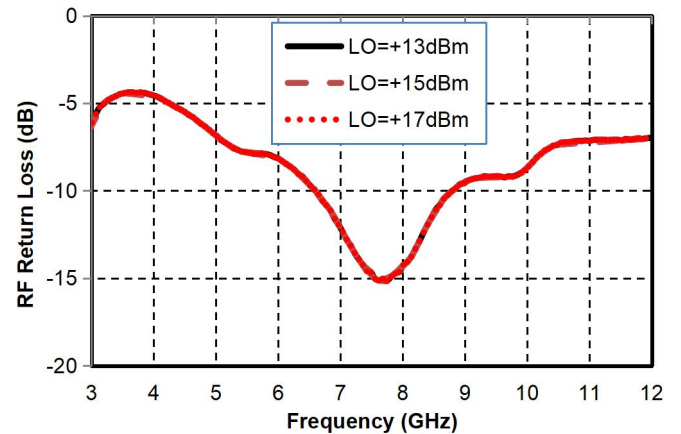

LO Return Loss Vs. Frequency

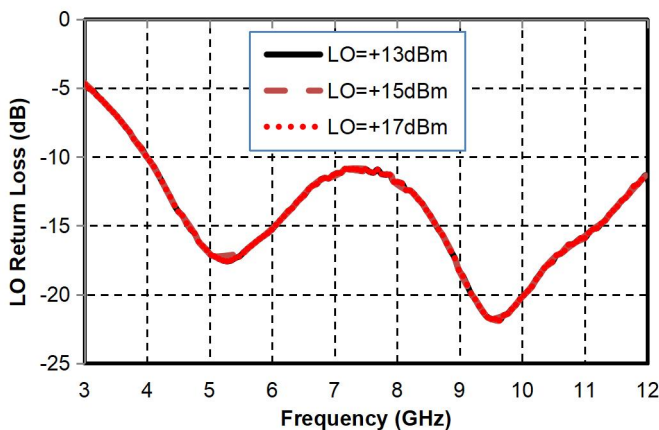

Upconversion Loss vs. LO Power

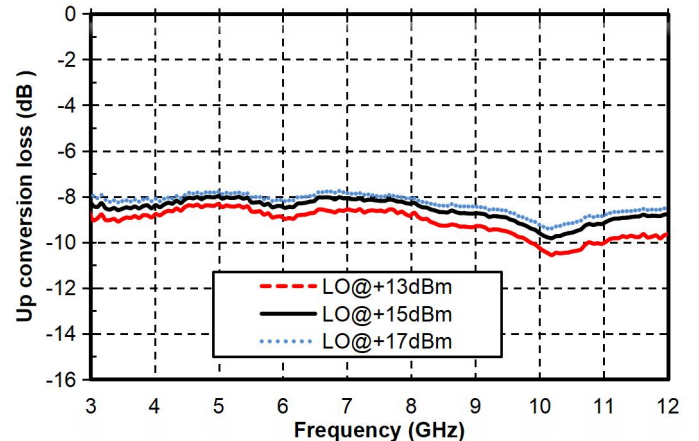

## GaAs MMIC Mixer Chip, 3GHz-12GHz

Down-conversion IF bandwidth, return loss  
@LO=3G, 15dBm

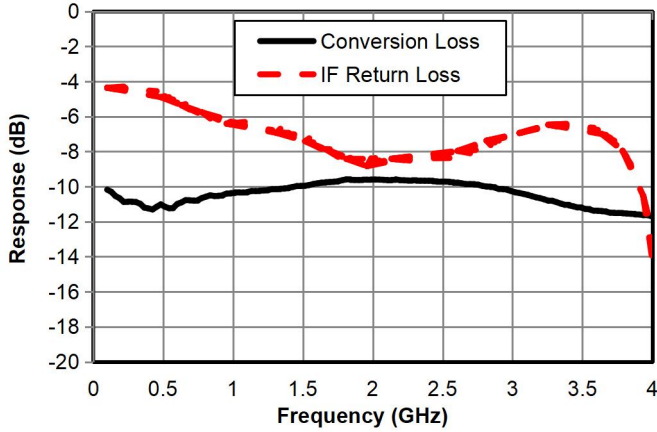

Down-conversion IF bandwidth, return loss  
@LO=4G, 15dBm

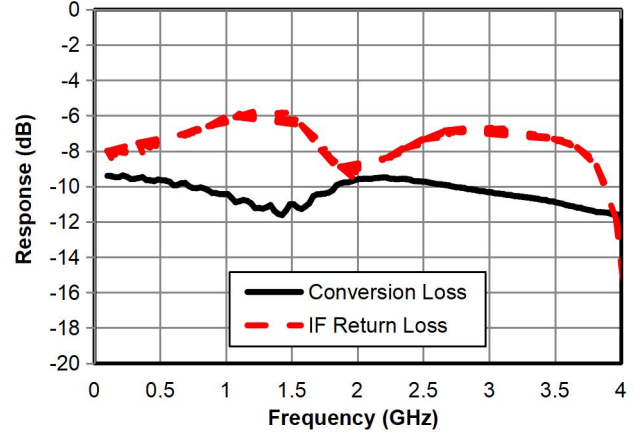

Down-conversion IF bandwidth, return loss  
@LO=11G, 15dBm

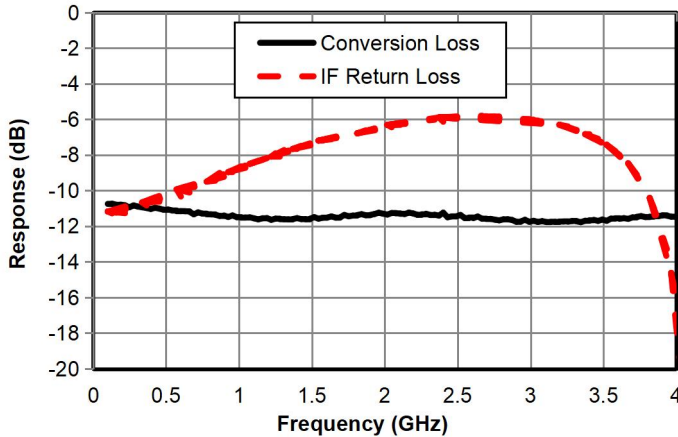

Down-conversion IF bandwidth, return loss  
@LO=12G, 15dBm

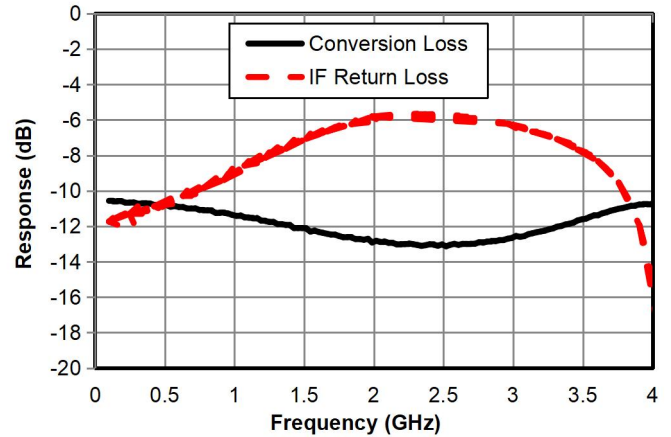

IIP3

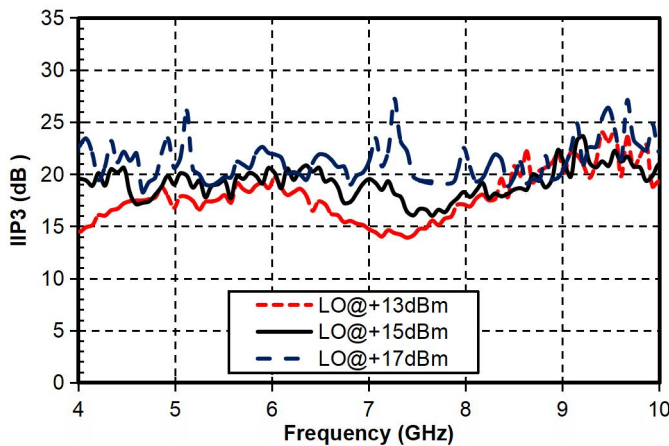

P-1 vs. Frequency

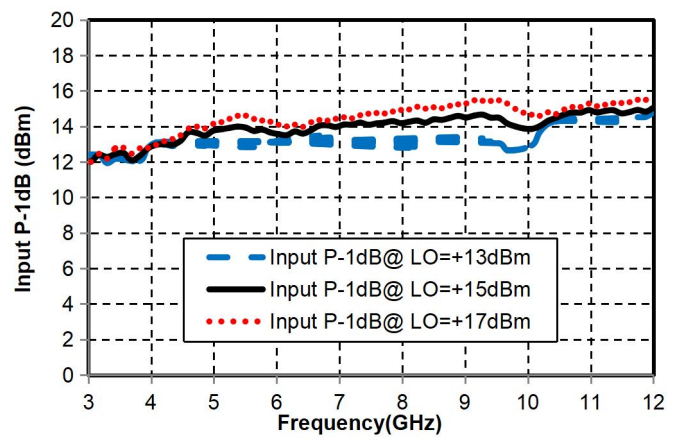

## GaAs MMIC Mixer Chip, 3GHz-12GHz

### LO harmonic leakage

LO(GHz) 15dBm	nLO (measured at RF port) dBc		
	1	2	3
3	x	33.19	67.56
4	x	30.15	59.69
5	x	38.04	57.48
6	x	51.73	66.59
7	x	45.08	44.84
8	x	52.24	43.39
9	x	53.98	54.67
10	x	57.07	49.67
11	x	48.18	51.56
12	x	45.42	52.76

### LO harmonic leakage

LO(GHz) 15 dBm	nLO (measured at IF port) dBc		
	1	2	3
3	x	63.4	52.15
4	x	66.1	47.79
5	x	65.87	53.67
6	x	64.66	50.56
7	x	62.25	54.78
8	x	59.98	47.57
9	x	63.09	44.85
10	x	58.51	47.33
11	x	66.46	53.29
12	x	66.99	55.52

## GaAs MMIC Mixer Chip, 3GHz-12GHz

### Down-conversion combined spurious suppression

mRF	nLO				
	0	1	2	3	4
0	/	-4.17	29.28	18.03	39.74
1	21.08	0	29.96	50.97	49.61
2	81.44	41.15	61.95	40.68	93.21
3	85.26	86.96	78.08	64.8	73.82
4	100.21	91.7	/	78.53	90.87

Test conditions: RF=4.1GHz@-10dBm, LO=4GHz@15dBm, all values are relative values of  $1*RF-1*LO(P_{IF},dBm)$ , unit: dBc .

mRF	nLO				
	0	1	2	3	4
0	/	6.14	25.54	13.2	44.17
1	47.96	0	52.16	49.32	60.1
2	80.25	67.79	77.96	66.92	79.84
3	85.25	85.68	102.27	60.69	/
4	/	/	/	104.23	110.96

Test conditions: RF = 9.1GHz@-20dBm , LO = 9GHz @ 15dBm , all values are relative values of  $1*RF-1*LO(P_{IF},dBm)$ , unit is dBc .

## GaAs MMIC Mixer Chip, 3GHz-12GHz

### Up-conversion combined spurious suppression

iF	nLO				
	0	1	2	3	4
0	/	23.67	-2.18	28.12	19.17
1	50.34	0	33.15	11.46	29.25
2	73.18	45.28	41	56	46.08
3	107.62	58.07	82.47	58.8	69.49
4	86.85	83.86	68.88	91.44	69.17

Test conditions: IF=0.3GHz@-10dBm, LO=4GHz@15dBm, all values are relative values of  $1 * LO^{-1} * IF = 3.7\text{GHz}$  ( P\_RF , dBm ), unit: dBc .

iF	nLO				
	0	1	2	3	4
0	/	27.48	18.7	9.74	21.96
1	37.08	0	26.8	24.56	34.69
2	54.4	55.52	46.35	59.21	51.12
3	95.63	63.42	75.77	55.26	78.48
4	78.99	94.91	75.39	93.9	78.72

Test conditions: RF = 1.3 GHz @ -10dBm , LO = 8 GHz@ 15dBm , all values are relative values of  $1 * LO^{-1} * IF = 6.7\text{GHz}$  ( P\_RF , dBm ), unit: dBc .

## GaAs MMIC Mixer Chip, 3GHz-12GHz

### Appearance structure <sup>2</sup>

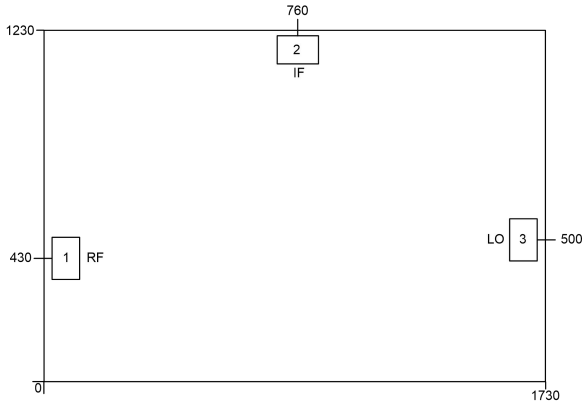

【2】 The units in the figure are all micrometers (dimensional tolerance:  $\pm 50\mu\text{m}$ .)

### Recommended assembly drawing

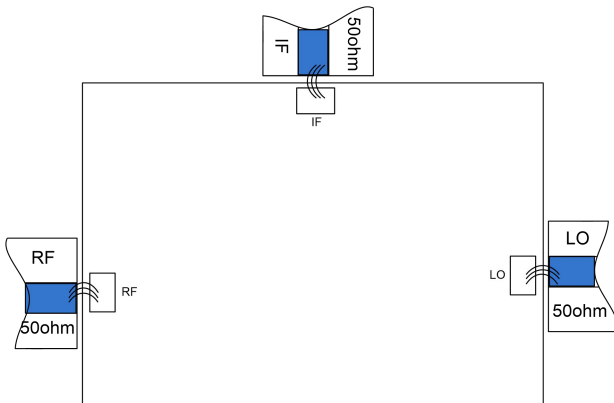

### Bonding point definition

Bonding point number	Function Symbol	Functional Description
1	RF	RF signal end, requires external DC blocking capacitor
2	IF	Intermediate frequency signal end, requires external DC blocking capacitor
3	LO	The local oscillator signal terminal requires an external DC blocking capacitor
Chip bottom	GND	The bottom of the chip needs to be well grounded to RF and DC

Note 1: LO and RF ports can be used interchangeably, but the electrical performance indicators may vary.

Note 2: It is recommended to solder three gold bonding wires to the pad.