

GaAs MMIC Mixer Chip, 0.4GHz-2GHz

Performance characteristics

- RF/LO frequency range: 0.4-2GHz
- IF frequency range: DC-0.6GHz
- Conversion loss: 10.0dB@15dBm LO input
- LO-RF isolation degree: 48dB
- LO-IF isolation degree: 39dB
- RF-IF isolation degree: 21dB
- Local oscillator power: +13dBm~+17dBm
- Chip size: QFN5x5mm

Principle Block Diagram

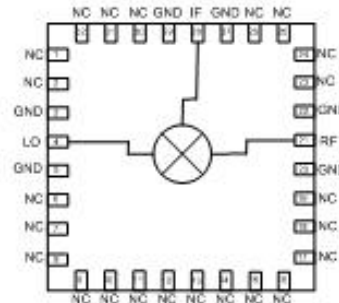

Product Introduction

GMX-004020A-CQ5 is a GaAs MMIC dual balanced mixer with a frequency range of 0.4GHz~2GHz and an intermediate frequency range of DC~0.6GHz. The frequency conversion loss is 10.0dB, and the local oscillator/radio frequency isolation degree is 48dB, 39dB, and 21dB, respectively. The typical local oscillator input power is +15dBm. RF, LO, and IF ports have no DC blocking capacitors. The mixer adopts a 5X5mm surface mount lead-free ceramic tube shell, and the surface of the pin solder pads is treated with a gold plating process, suitable for reflow soldering installation process.

Use restriction parameters¹

Maximum RF input power	+22dBm
Maximum local oscillator input power	+22dBm
Maximum intermediate frequency input power	+22dBm
Working temperature	-55 ~ +85°C
Storage temperature	-65 ~ +150°C

【1】 Exceeding any of the above maximum limits may result in permanent damage.

Electrical performance parameters($T_A = +25^\circ\text{C}$, IF=100MHz, LO=+15dBm)

Index	Minimum value	Typical value	Maximum value	Unit
RF frequency range		0.4-2		GHz
Local oscillator frequency range		0.4-2		GHz
Intermediate frequency		DC-0.6		GHz
Variable frequency loss	-	10.0	-	dB
LO-RF isolation degree	-	48	-	dB
LO-IF isolation degree	-	39	-	dB
RF-IF isolation	-	21	-	dB

degree			
RF input P-1dB		13.5	dBm
IIP3		15.5	dBm
The above parameters are all tested in down conversion mode, with an intermediate frequency of 0.1GHz and a local oscillator power of +15dBm.			

GaAs MMIC Mixer Chip, 0.4GHz-2GHz

Main indicator testing curve

Downconversion loss vs. Temperature @
LO=+15dBm

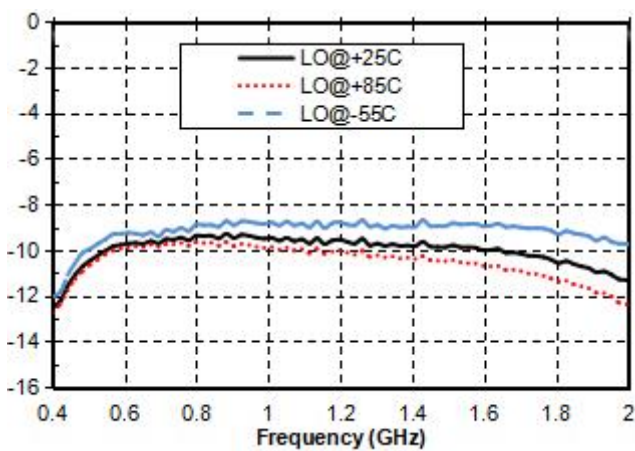

Isolation degree @ LO=+15dBm

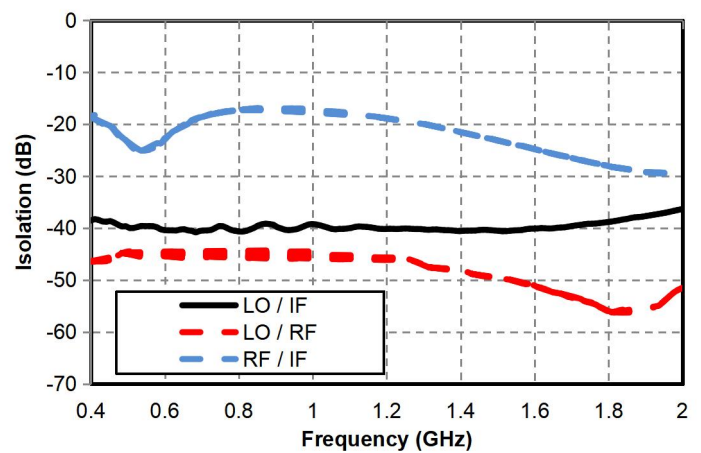

Intermediate frequency bandwidth @
LO=0.4G/+15dBm

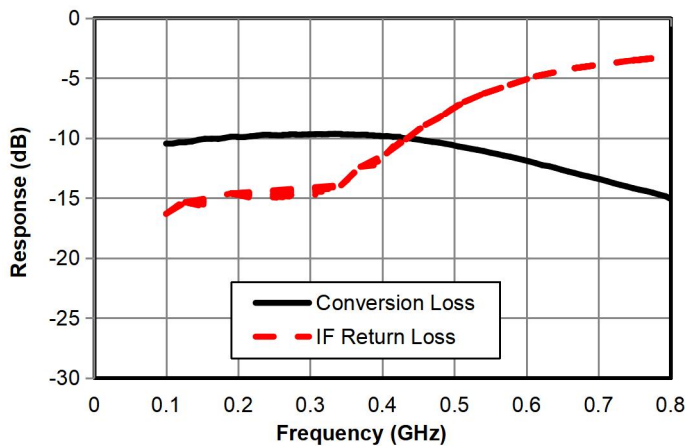

Intermediate frequency bandwidth @
LO=2G/+15dBm

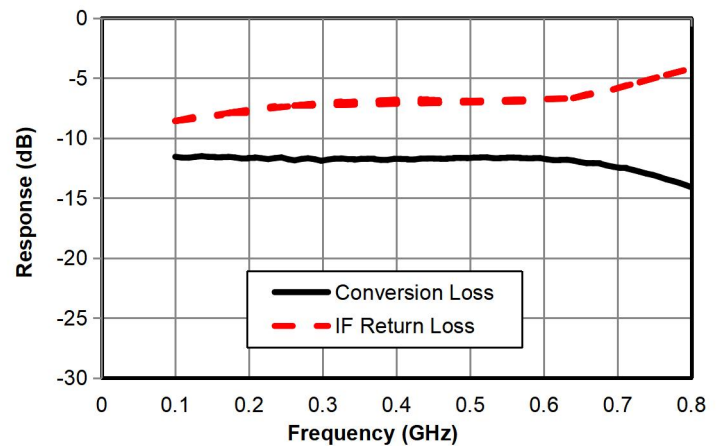

Downconversion frequency conversion loss vs.
LO power

Downconversion RF return loss vs. Frequency
LO=+15dBm

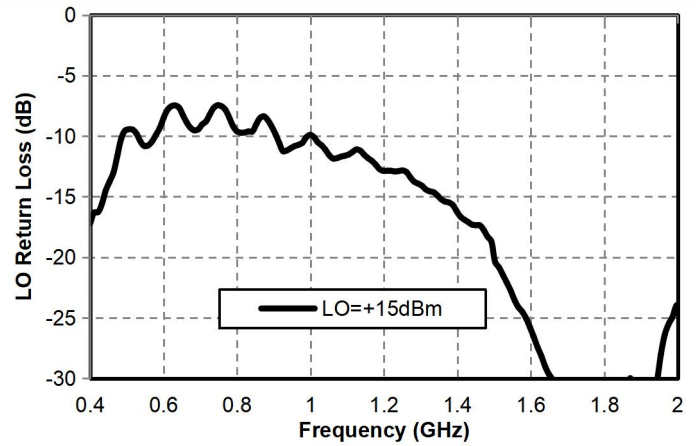
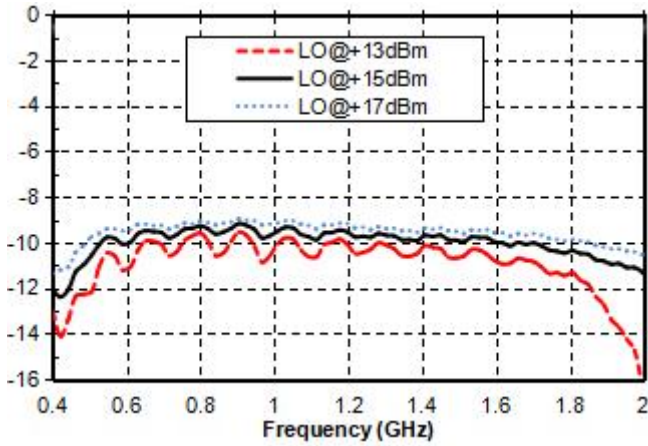

GaAs MMIC Mixer Chip, 0.4GHz-2GHz

Downconversion local oscillator standing wave vs. frequency

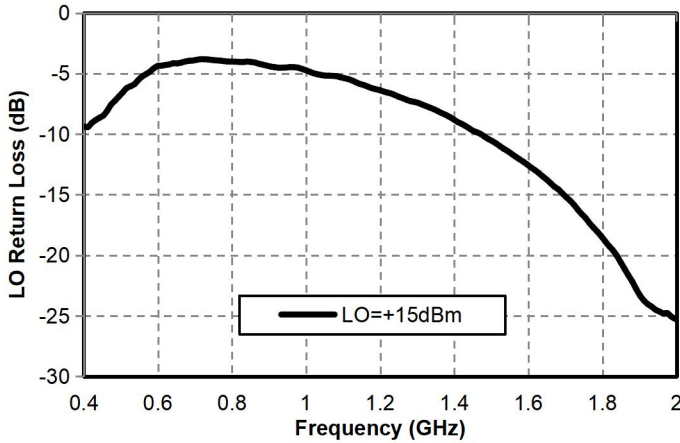

Upconversion loss vs. LO power

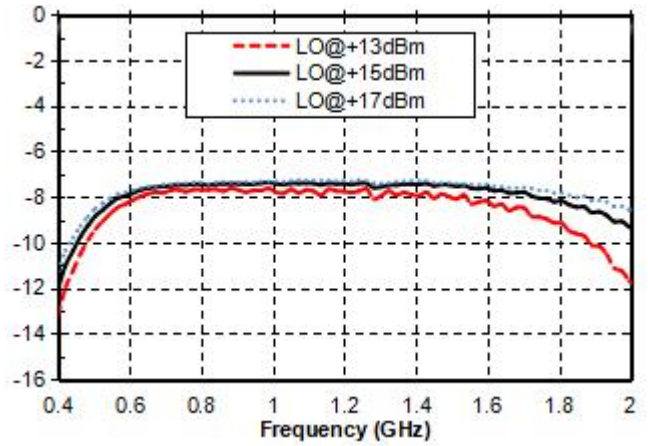

IIP3

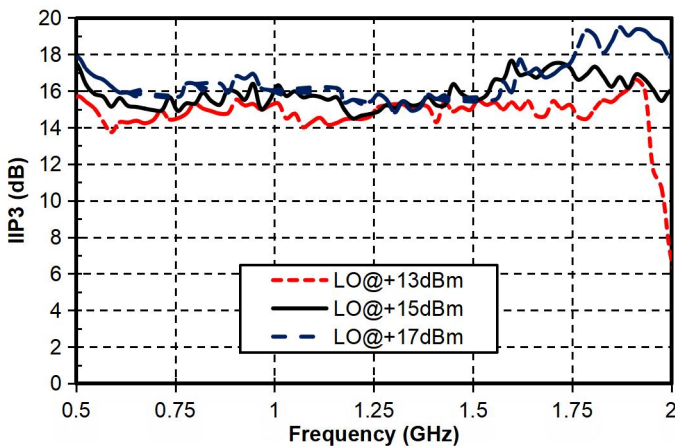

Input P-1dB vs. frequency

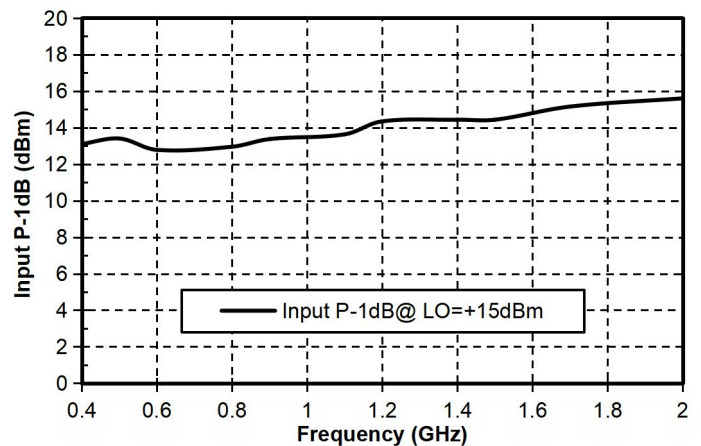

Local oscillator harmonic leakage

LO(GHz)15dBm	nLO (Tested on RF port) dBc	
	2	3
0.4	45	55
0.6	45	65
0.8	42	68
1	41	53
1.2	44	55
1.4	46	58
1.5	46	58
1.6	52	61
1.8	62	66
2	57	65

GaAs MMIC Mixer Chip, 0.4GHz-2GHz

Lower combination spurious suppression

Combined Stray Testing	nLO				
	0	1	2	3	4
mRF	0	1	2	3	4
0	xxx	6	43	23	35
1	9	0	28	46	45
2	69	65	65	56	89
3	68	80	89	58	75
4	77	86	82	85	86

RF= 1.1GHz@-10dBm , LO= 1GHz@15dBm The relative value of 1 * RF-1 * LO (P_IF, dBm) is expressed in dBc.

Upconversion combination stray suppression

Combined Stray Testing	nLO				
	0	1	2	3	4
mIF	0	1	2	3	4
0	xxx	13	8	21	24
1	8	0	29	16	48
2	55	51	52	58	57
3	69	88	72	50	72
4	67	86	68	67	66

IF= 0.3GHZ@-10dBm , LO= 1GHZ@15dBm The relative value of 1 * RF-1 * LO (P_IF, dBm) is expressed in dBc.

External structure

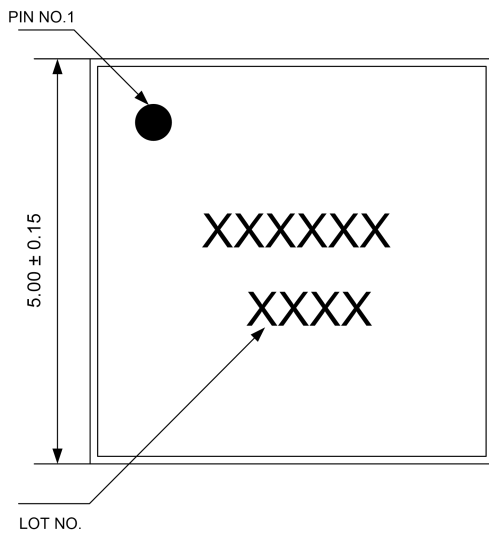

vertical view

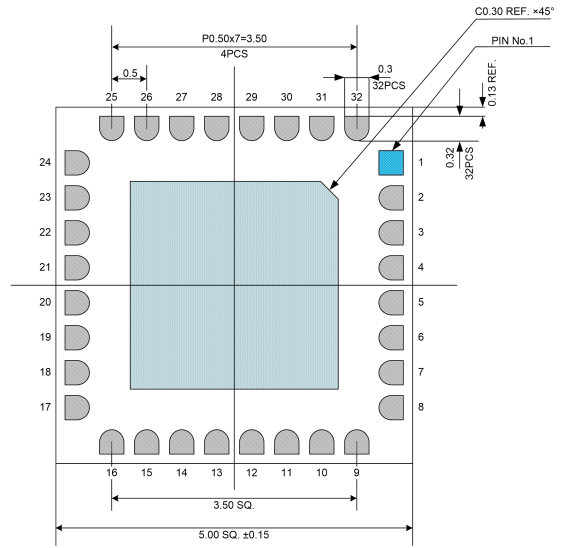

Top view

GaAs MMIC Mixer Chip, 0.4GHz-2GHz

External structure

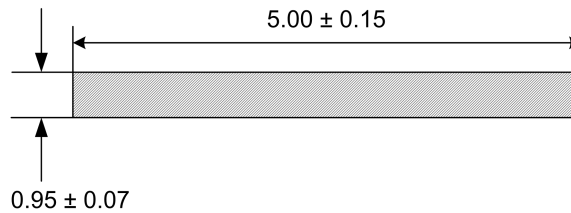

Side view

The units in the figure are all millimeters, with an unspecified tolerance of $\pm 0.15\text{mm}$

Pin Definition

Solder joint serial number	Functional symbols	Function Description
4	LO	The local oscillator signal terminal requires an additional DC isolation capacitor
21	RF	RF signal terminal requires an additional DC isolation capacitor
28	IF	Intermediate frequency signal terminal requires an additional DC isolation capacitor
3、5、20、22、27、29	GND	The pins should have sufficient and good contact with the RF and DC ground
Chip bottom	GND	The bottom of the chip needs to be well grounded with RF and DC
other	NC	No welding required

Application Block Diagram

