

GaAs MMIC Limiter Chip, 2.7-3.5GHz

Performance characteristics

- Range : 2.7-3.5 GHz
- Insertion loss : 0.5 dB (Tpy .)
- Clipping level: 15dBm
- Power handling: 150W (CW)
- 50Ohm input / output
- 100% on-wafer testing
- Chip size: 2.42 x 2.77 x 0.1mm

Functional Block Diagram

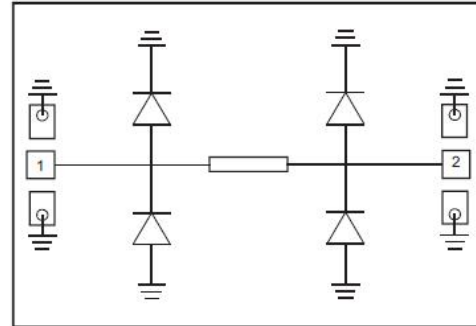

Product Introduction

GLM-027035A is a GaAs MMIC limiter with a frequency range of 2.7~3.5GHz , 50Ω input/output , 0.5dB within the operating frequency band , 1.2 input and output standing wave , and 150W burnout resistance. The chip is small in size, with no DC blocking capacitor at the input and DC blocking capacitor at the output . The chip uses on-chip through-hole metallization technology to ensure good grounding, no additional grounding measures are required, and it is simple and convenient to use. The back of the chip is metallized, suitable for eutectic sintering or conductive adhesive bonding.

Use restriction parameter ¹

Maximum input power	51.7dBm(CW)
Operating temperature	-55 ~ + 125 °C
Storage temperature	-65 ~ +150°C

【1】 Exceeding any of these maximum limits may cause permanent damage.

Electrical performance parameters (TA = +25°C)

Index	Minimum	Typical Value	Maximum	Unit
Frequency Range	2.7-3.5			GHz
Insertion loss	-	0.5	-	dB
Input return loss	-	19	-	dB
Output return loss	-	20	-	dB
Clipping level	-	15	-	dBm
Burnout resistance (CW)*	-	51.7	-	dBm

*Continuous input 51.7dBm (CW), duration 5 minutes.

GaAs MMIC Limiter Chip, 2.7-3.5GHz

Main index test curve

Insertion Loss vs. Operating Frequency

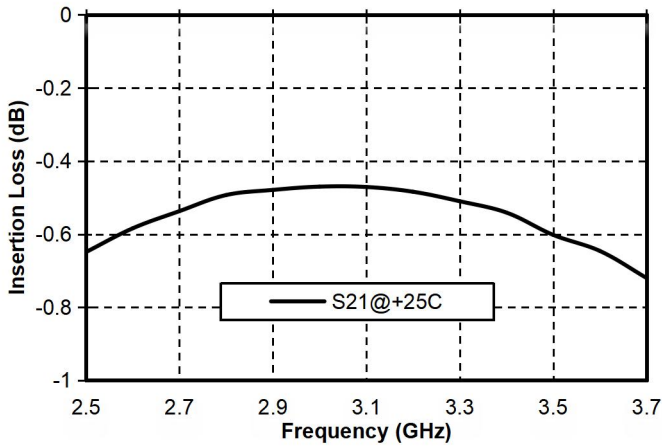

Input Standing Wave vs. Operating Frequency

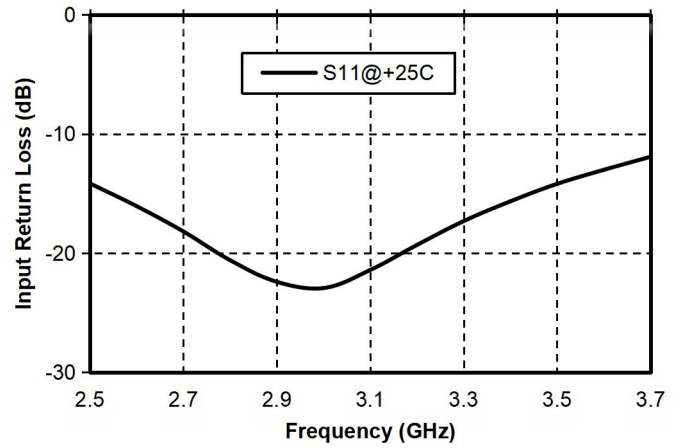

Output Standing Wave vs. Operating Frequency

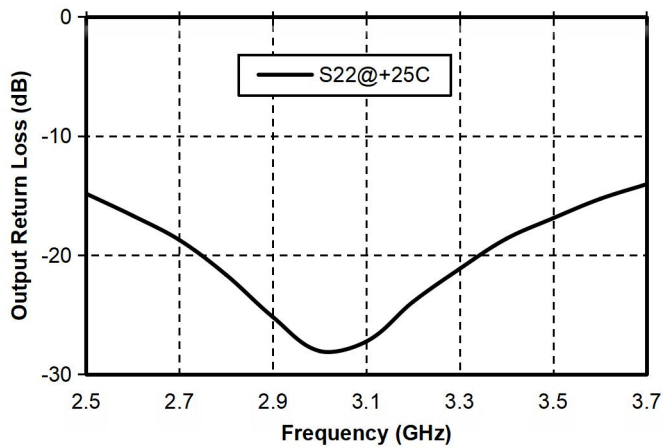

Clipping level@3.5G

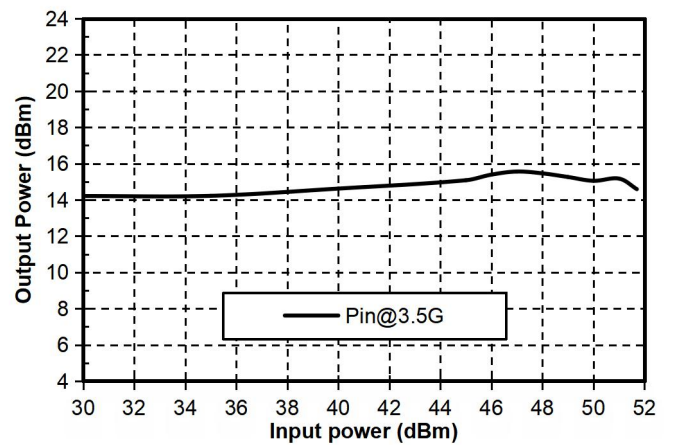

Appearance structure ²

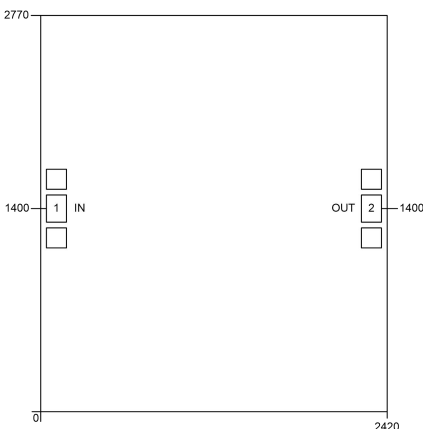

【 2 】 All units in the figure are micrometers

GaAs MMIC Limiter Chip, 2.7-3.5GHz

Recommended assembly drawing

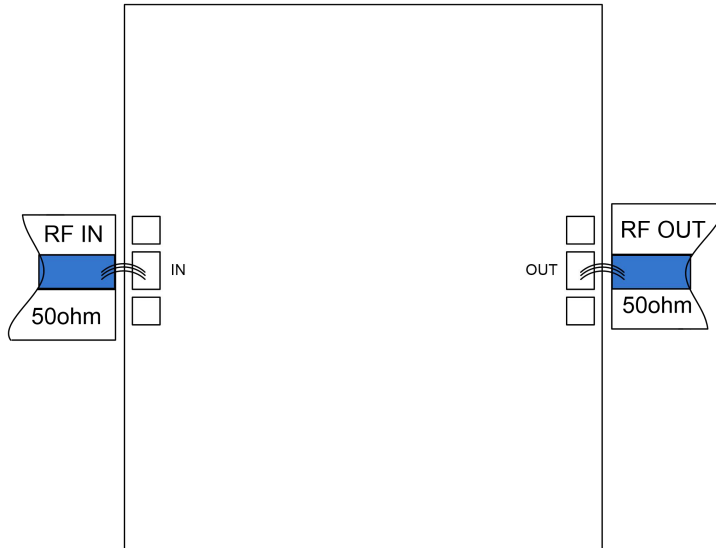

It is recommended to use three gold wires for input and output bonding.

Bonding point definition

Bonding point number	Function Symbol	Functional Description
1	RF IN	RF signal input terminal , no DC blocking capacitor
2	RF OUT	RF signal output terminal , with integrated DC blocking capacitor
Chip bottom	GND	The bottom of the chip needs to be well grounded to RF and DC

Precautions for use

- The chip needs to be stored in an anti-static container and kept in a nitrogen environment.
- bare die surface using wet chemical methods .
- Please strictly comply with ESD protection requirements to avoid electrostatic damage to bare chips.
- General operation: Please use precision pointed tweezers to pick up bare chips. Avoid touching the chip surface with tools or fingers during operation.
- Rack mounting operation suggestions: Bare chip mounting can be done by AuSn solder eutectic sintering or conductive adhesive bonding. The mounting surface must be clean and flat.
- Sintering process: It is recommended to use AuSn solder sheets with a gold -tin ratio of 80/20 . The working surface temperature reaches 255 °C and the tool (vacuum chuck) temperature reaches 265 °C . When the high-temperature mixed gas (nitrogen-hydrogen ratio of 90/10) is blown to the chip, the temperature at the top of the tool should be raised to 290 °C . Do not let the chip exceed 320 °C for more than 20 seconds. The friction time should not exceed 3 seconds.
- Bonding process: The amount of conductive glue dispensed should be as small as possible. After

the chip is placed in the installation position , the conductive glue should be vaguely visible around it . For curing conditions, please follow the information provided by the conductive glue manufacturer.

- Bonding operation suggestions: Use $\Phi 0.025\text{mm}$ (1mil) gold wire for both ball and wedge bonding . Thermo-ultrasonic bonding temperature is $150\text{ }^{\circ}\text{C}$. The pressure of the wedge for ball bonding is $40\sim 50\text{gf}$, and the pressure of the wedge bonding is $18\sim 22\text{gf}$. Use the smallest possible ultrasonic energy. The bonding starts at the pressure point on the chip and ends at the package (or substrate) .