

## GaAs MMIC Limiter Chip, 0.5 - 4 GHz

### Performance characteristics

- Frequency range: 0.5 - 4 GHz
- Insertion loss : 0.6 dB ( Tpy .)
- Limiting level: 15dB m
- Power handling: 47dBm (CW)
- 50Ohm input / output
- Chip size: QFN 4X4

GLM-0004D-CQ4 is a GaAs MMIC limiter with a frequency range of 0.5~4GHz , an insertion loss of 0.5dB within the operating frequency band , an input and output standing wave of 1.5 , and an anti-burnout power of 47dBm. The amplifier uses a 4X4mm surface-mount leadless ceramic tube shell to achieve airtight packaging. The surface of the pin pad is gold-plated and is suitable for reflow soldering installation.

Electrical performance parameters ( TA = +25°C)				
Index	Minimum	Typical Value	Maximum	Unit
Frequency Range	0.5-4			G Hz
Insertion loss	-	0.6	-	dB
Input return loss	-	19	-	dB
Output return loss	-	17	-	dB
Clipping level	-	15	-	dBm
Anti-burning power	-	-	47	dBm

### Main index test curve

Insertion Loss vs. Operating Frequency

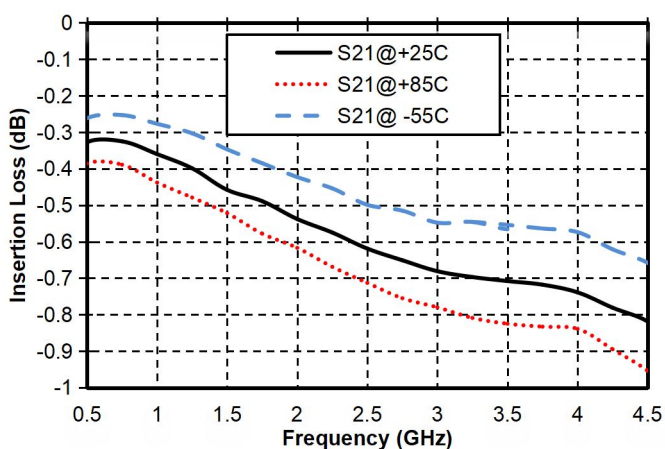

Input Standing Wave vs. Operating Frequency

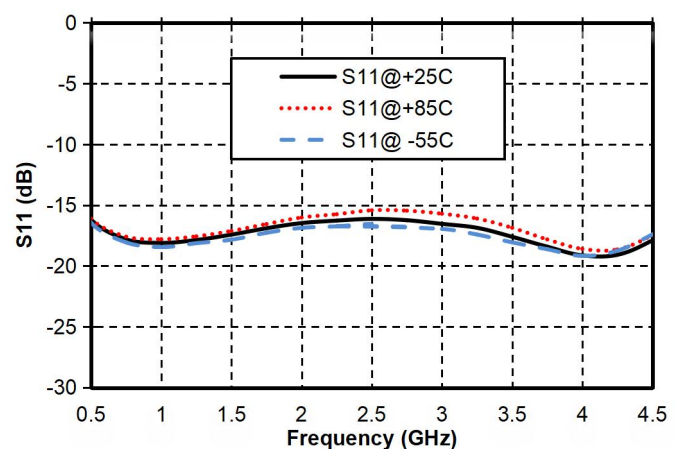

## GaAs MMIC Limiter Chip, 0.5 - 4 GHz

Output Standing Wave vs. Operating Frequency

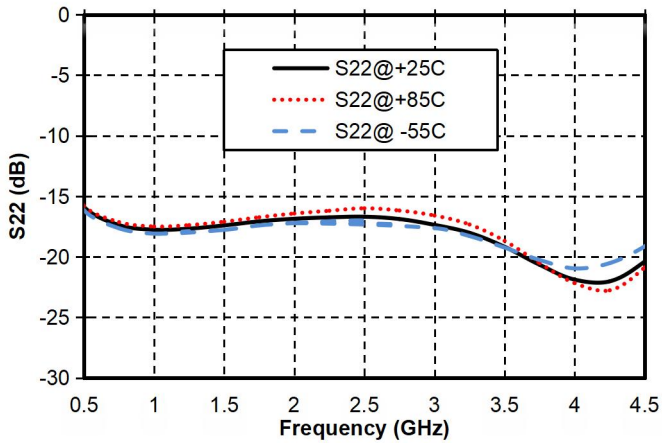

Clipping level@4G

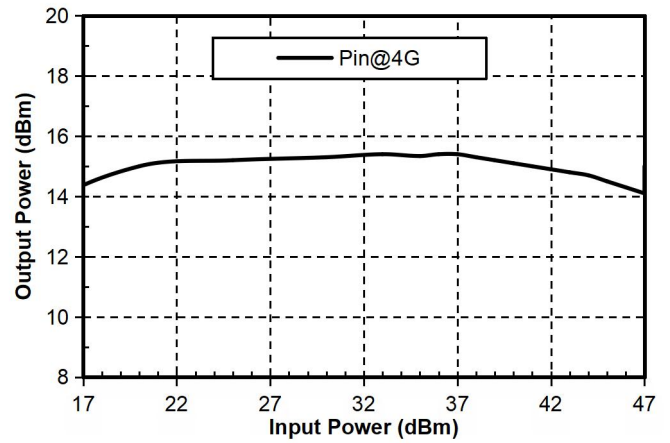

### Appearance structure

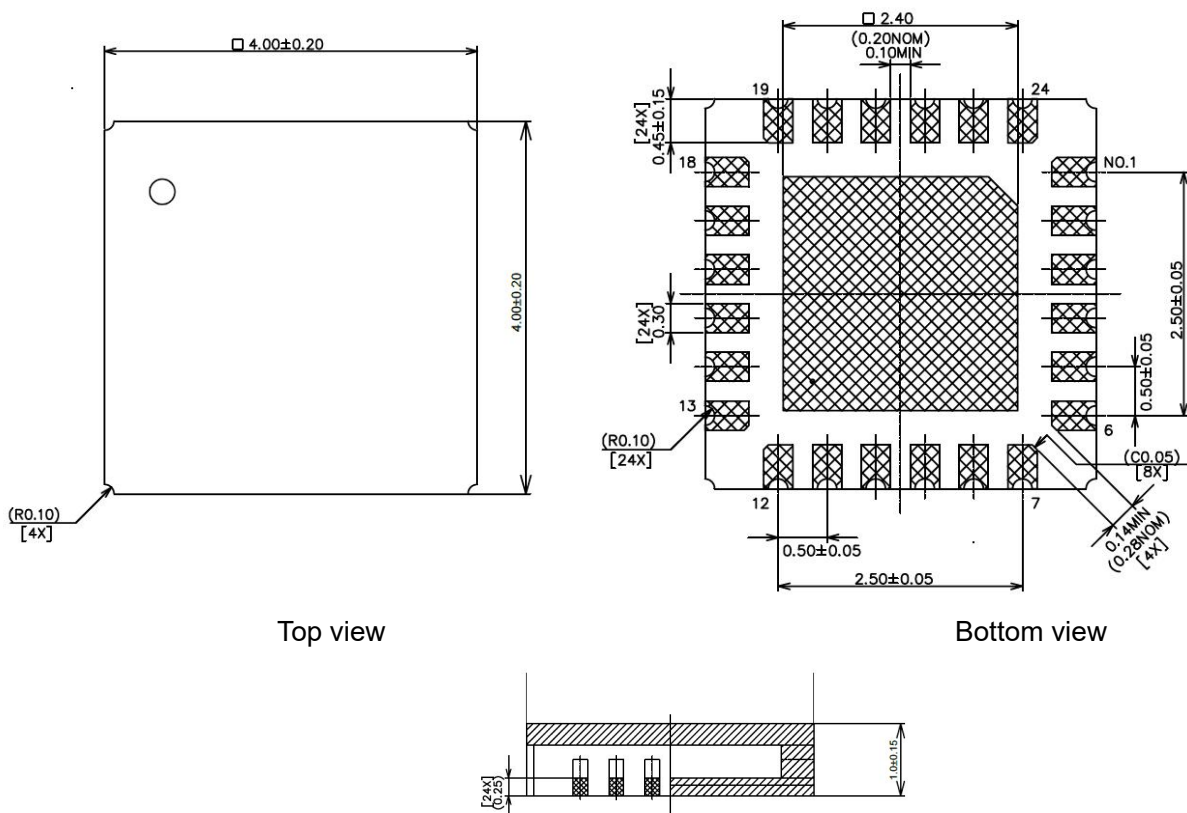

Top view

Bottom view

Side View

All units in the figures are millimeters .

## GaAs MMIC Limiter Chip, 0.5 - 4 GHz

Recommended assembly drawing

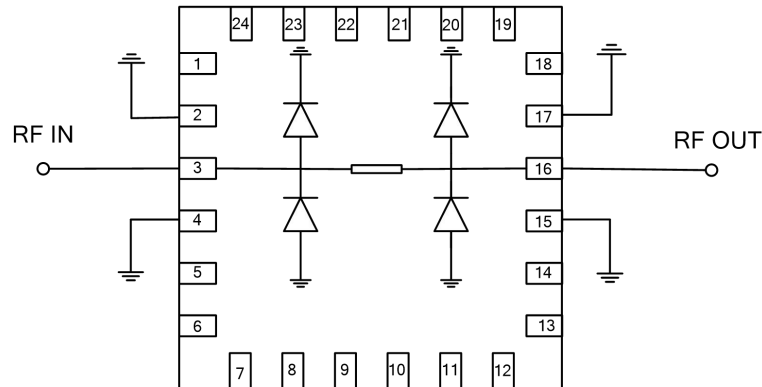

### Pin Definition

Bonding point number	Function Symbol	Functional Description
3	RFIN	RF signal input terminal. The chip input terminal does not integrate a DC blocking capacitor . It is recommended to connect an external DC blocking capacitor.
16	RFOUT	RF signal output terminal, no DC blocking capacitor required
2, 4, 15, 17	GND	The bottom of the chip needs to be well grounded to RF and DC
1, 5~14, 18~24	NC	No welding required

### Precautions for use

- Sealing material : Ceramic material that meets ROHS standards
- Lead frame material: copper alloy
- Lead surface plating: gold, gold layer thickness greater than 1.5um
- Maximum reflow peak temperature: 260 °C

### Use limit parameters

Maximum input power	+47dBm
Operating temperature	-55 ~ + 125 °C
Storage temperature	-65 ~ +150°C

Exceeding any of these maximum limits may cause permanent damage.