

GaAs MMIC Low Noise Amplifier Chip, 10 - 20 GHz

Performance characteristics

- Frequency Range: 10 - 20 GHz
- Small signal gain: 24dB
- Noise figure: 1.6dB Typ.
- P -1dB: 0.5dBm
- Power supply: + 5V /10mA
- 50Ohm input / output
- 100% on-wafer testing
- Chip size: QFN 4X4

Functional Block Diagram

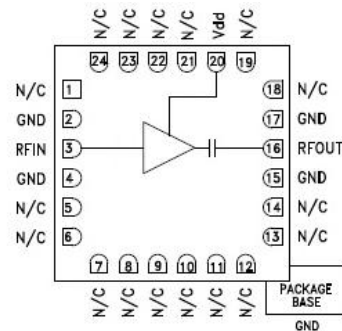

Product Introduction

GLA-1020C-CQ4 is a broadband low noise amplifier chip with a frequency range of 10GHz~20GHz, a small signal gain of 24dB, and an in-band noise figure of 1.6dB. GLA-1020C-CQ4 is powered by a single +5V power supply. The amplifier uses a 4X4mm surface-mount leadless ceramic tube shell to achieve airtight packaging. The surface of the pin pad is gold-plated and is suitable for reflow soldering installation.

Use limit parameters

Maximum drain voltage	+7V
Maximum input power	+20dBm
Operating temperature	-55 ~ +85°C
Storage temperature	-65 ~ +150°C

Exceeding any of these maximum limits may cause permanent damage.

Electrical performance parameters (TA = +25°C, Vd = +5V)

Index	Minimum	Typical Value	Maximum	Unit
Frequency Range	10-20			G Hz
Small Signal Gain	-	24	-	dB
Gain Flatness	-	± 0.5	-	dB
Noise Figure	-	1.6	-	dB
P -1dB	-	0.5	-	dBm
Psat	-	2	-	dBm
Input return loss	-	14	-	dB
Output return loss	-	11	-	dB
Quiescent Current	-	10	-	mA

GaAs MMIC Low Noise Amplifier Chip, 10 - 20 GHz

Main index test curve

Gain vs. Frequency

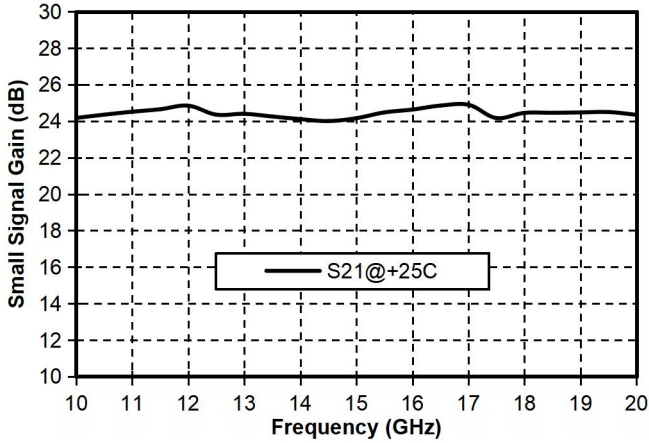

Noise Figure vs. Frequency

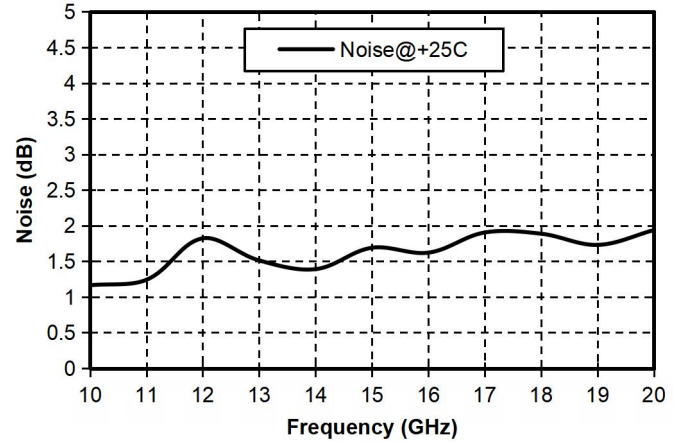

Input Return Loss vs. Frequency

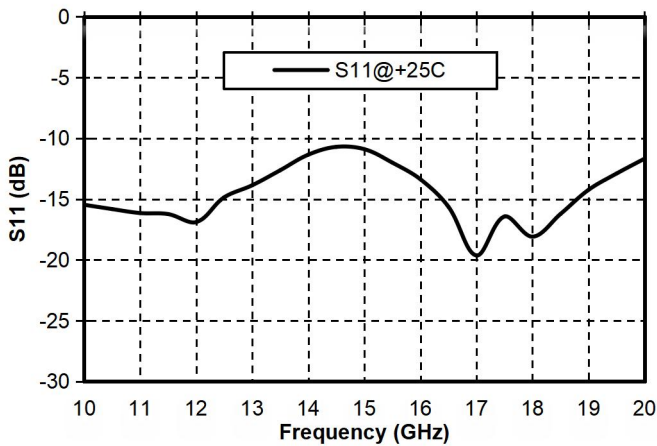

Output Return Loss vs. Frequency

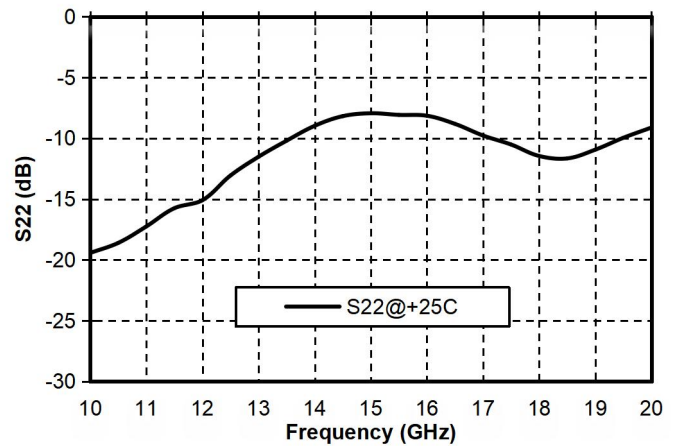

Reverse Isolation vs. Frequency

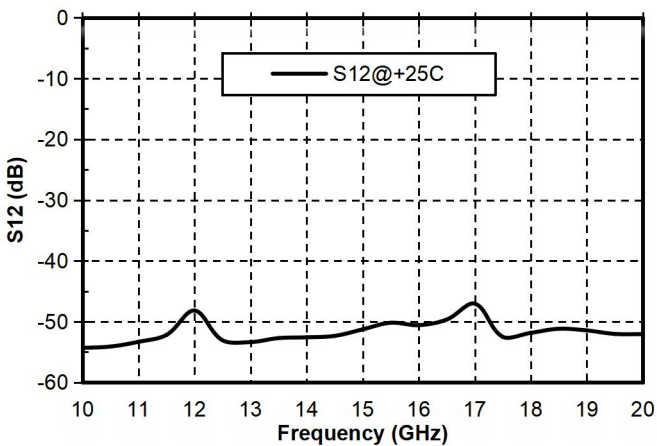

P-1dB vs. Frequency

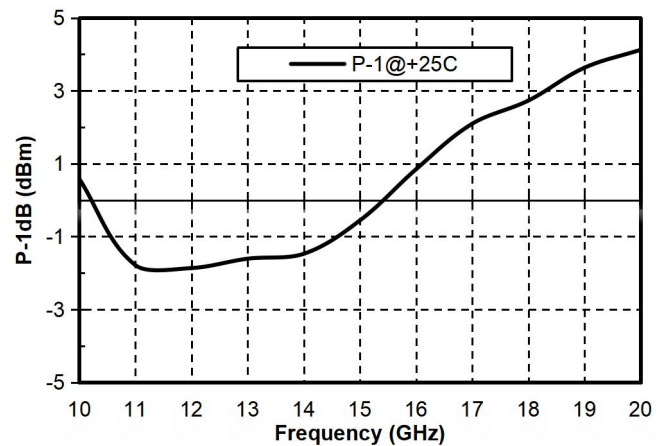

GaAs MMIC Low Noise Amplifier Chip, 10 - 20 GHz

Recommended Circuit

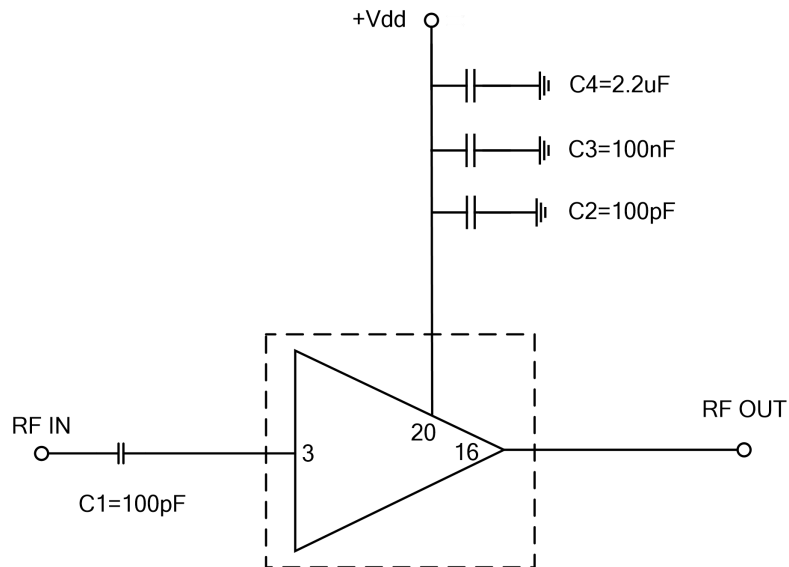

Raw material	Capacitance, inductance, resistance
C1	100pF
C 2	100pF
C 3	100nF
C4	2.2uF

Precautions for use

- Sealing material : Ceramic material that meets ROHS standards
- Lead frame material: copper alloy
- Lead surface plating: gold, gold layer thickness greater than 1.5um
- Maximum reflow peak temperature: 260 °C