

GaAs MMIC Low Noise Amplifier Chip, 2 - 6 GHz

Performance characteristics

- Frequency Range: 2 - 6 GHz
- Small Signal Gain: 27 dB
- Noise figure: 0.9dB typ.
- P -1 dB: 12.5dBm
- Power supply: + 5V /35mA
- 50Ohm input / output
- 100% on-wafer testing
- Chip size: QFN 3X3

Block Diagram

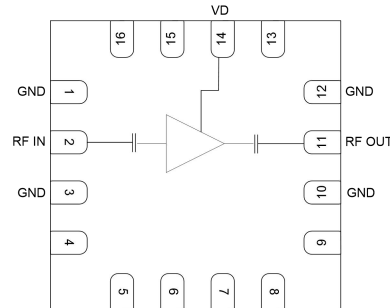

Product Introduction

GLA-0206-PQ3 is a broadband low noise amplifier chip with a frequency range of 2GHz~6GHz, a small signal gain of 27dB, and an in-band noise figure of 0.9dB . GLA -0206A-PQ3 is powered by a single +5V power supply. This chip is packaged in a 3 x 3 mm plastic surface mount package, and the surface of the pin pad is gold-plated, which is suitable for reflow soldering installation process.

Use restriction parameter ¹

Maximum drain voltage	+7V
Maximum input power	+20dBm
Operating temperature	-55 ~ +85°C
storage temperature	-65 ~ +150°C

【1】 Exceeding any of these maximum limits may cause permanent damage.

Electrical performance parameters (TA = +25°C, Vd = +5V)

Index	Minimum	Typical Value	Maximum	Unit
Frequency Range	2-6			G Hz
Small Signal Gain	-	27	-	dB
Gain Flatness		± 1.5		dB
Noise Figure	-	0.9	-	dB
P -1 dB	-	12.5	-	dBm
Psat	-	13.5	-	dBm
Input return loss	-	11	-	dB
Output return loss	-	17	-	dB
Quiescent Current		35		mA

GaAs MMIC Low Noise Amplifier Chip, 2-6 GHz

Main index test curve

Gain vs. Frequency

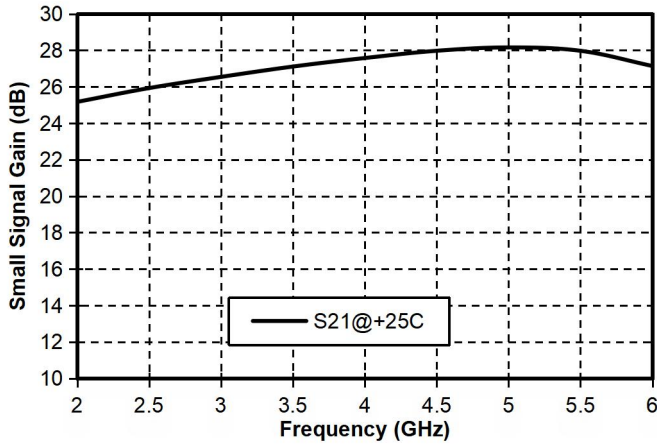

Noise Figure vs. Frequency

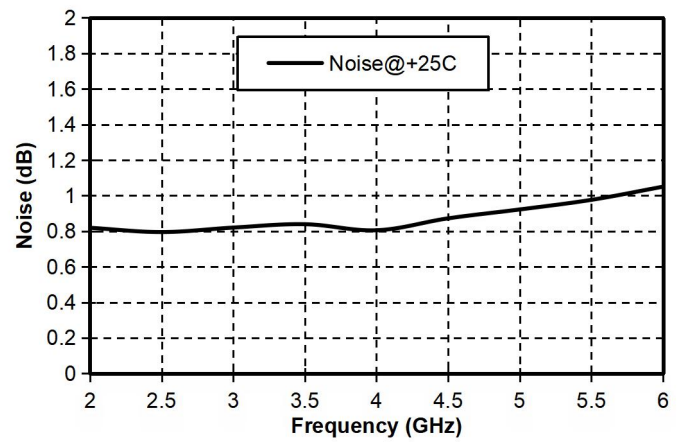

Input Return Loss vs. Frequency

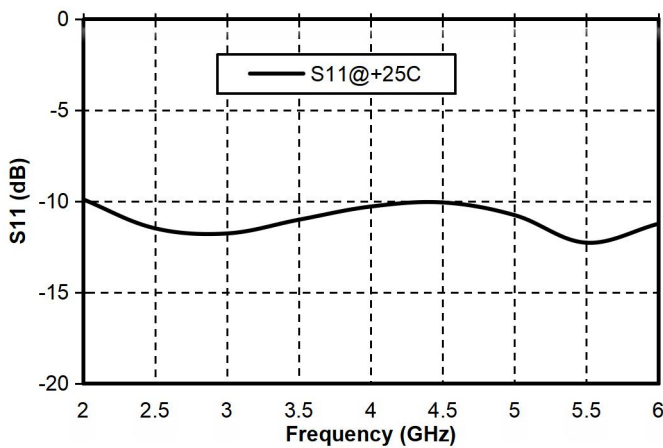

Output Return Loss vs. Frequency

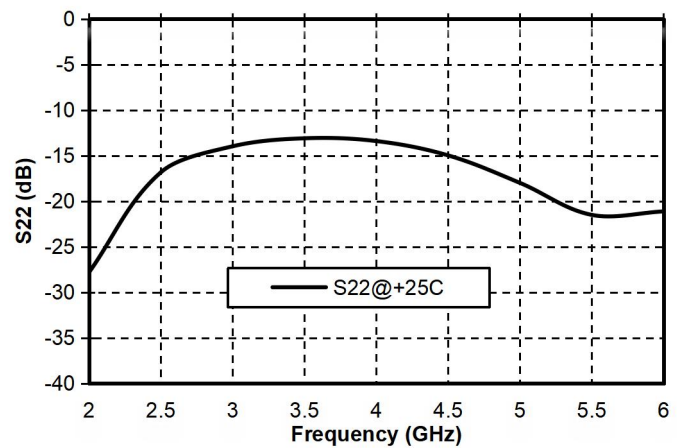

Reverse Isolation vs. Frequency

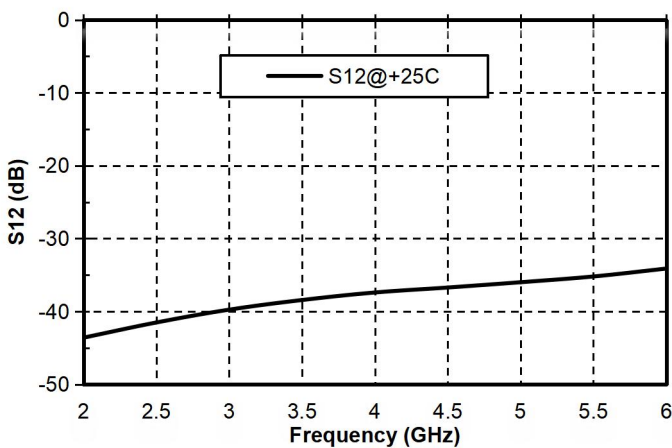

P-1dB vs. Frequency

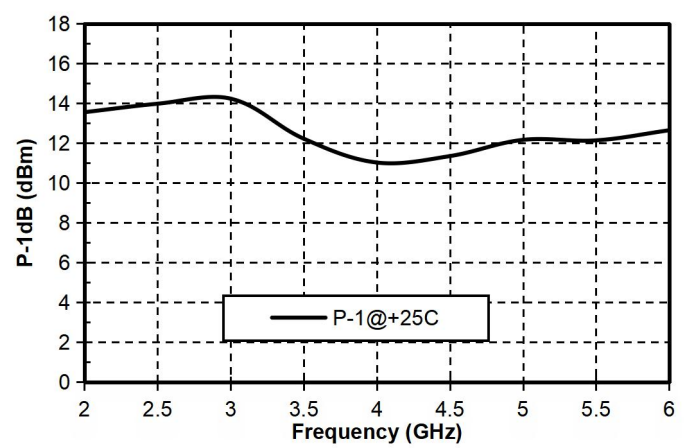

GaAs MMIC Low Noise Amplifier Chip, 2 - 6 GHz

Appearance structure

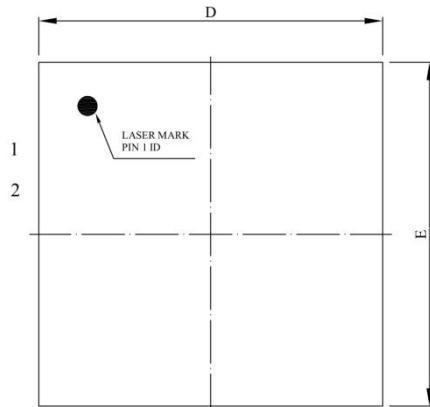

Top view

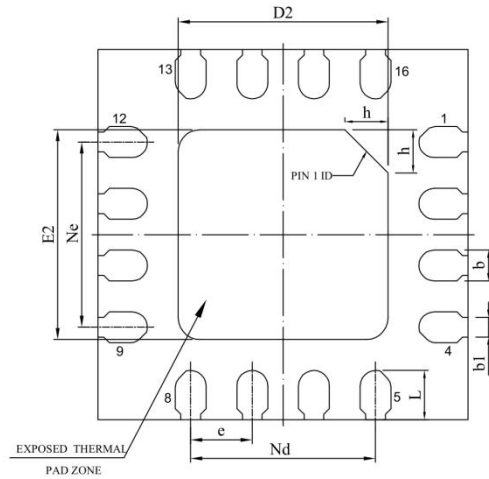

Bottom view

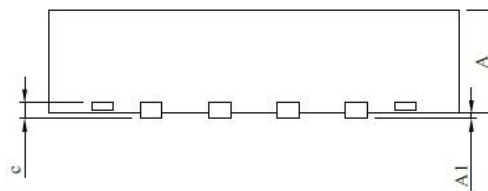

Side View

The units in the figure are all millimeters, with a tolerance of ± 0.05 mm.

Structure size							
Annotation	Minimum	standard	maximum	Annotation	Minimum	standard	maximum
A	0.70	0.75	0.80	e	0.50BSC		
A1	-	0.02	0.05	Ne	1.50BSC		
b	0.17	0.22	0.27	Nd	1.50BSC		
b1	0.18REF			E	2.90	3.00	3.10
c	0.203REF			E2	1.60	1.70	1.80
D	2.90	3.00	3.10	L	0.25	0.30	0.35
D2	1.60	1.70	1.80	h	0.25	0.30	0.35

All units in the figures are millimeters .

GaAs MMIC Low Noise Amplifier Chip, 2 - 6 GHz

Pin Definition		
Bonding point number	Function Symbol	Functional Description
2	RFIN	RF signal input terminal, no DC blocking capacitor required
11	RFOUT	RF signal output terminal, no DC blocking capacitor required
14	VDD	Amplifier Drain Bias
1, 3, 10, 12	GND	The bottom of the chip needs to be well grounded to RF and DC
4~9, 13, 15, 16	NC	No welding required

Recommended Circuit

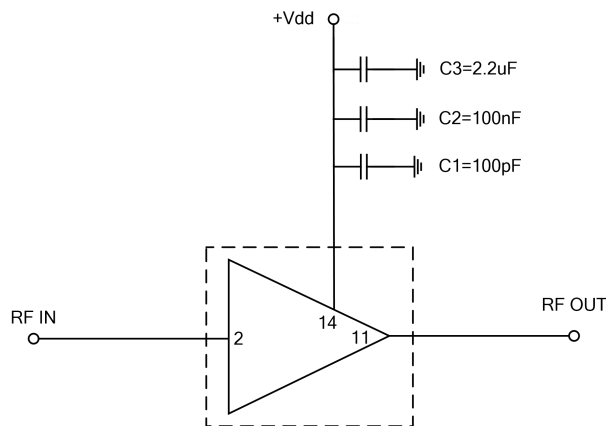

Raw material	Capacitance, inductance, resistance
C1	100pF
C 2	100nF
C 3	2.2uF

Precautions for use

- Sealing material : Low-pressure injection molding plastic that meets ROHS specifications
- Lead frame material: copper
- Lead surface plating: nickel palladium gold
- Maximum reflow peak temperature: 260 °C