

## GaAs MMIC Low Noise Amplifier Chip, 2 - 4 GHz

### Performance characteristics

- Frequency range: 2 - 4 GHz
- Small signal gain: 30.5dB
- Noise figure: 0.55dB Max.
- P -1 dB: 7.5dBm
- Power supply: + 5V /20mA
- 50Ohm input / output
- 100% on-wafer testing
- Chip size: QFN 4X4

### Functional Block Diagram

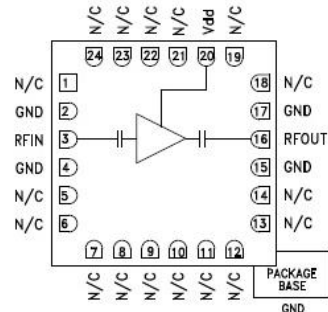

### Product Introduction

GLA-0204C-CQ4 is a broadband low noise amplifier chip with a frequency range of 2GHz~4GHz, a small signal gain of 30.5dB, and an in-band noise figure of 0.65dB. GLA-0204C-CQ4 is powered by a single +5V power supply. This chip is packaged in a 4 x 4 mm ceramic surface mount package, which can achieve airtight packaging. The surface of the pin pad is gold-plated, which is suitable for reflow soldering installation process.

### Use limit parameters

Maximum drain voltage	+7V
Maximum input power	+20dBm
Operating temperature	-55 ~ +85°C
storage temperature	-65 ~ +150°C

Exceeding any of these maximum limits may cause permanent damage.

### Electrical performance parameters( TA = +25°C, Vd = +5V)

Index	Minimum	Typical Value	Maximum	Unit
Frequency Range	2-4			G Hz
Small Signal Gain	-	30.5	-	dB
Gain Flatness	-	± 0.5	-	dB
Noise Figure	-	0.5	-	dB
P -1dB	-	7.5	-	dBm
Psat	-	9.5	-	dBm
Input return loss	11	18	-	dB
Output return loss	12	17	-	dB
Quiescent Current	-	20	-	mA

## GaAs MMIC Low Noise Amplifier Chip, 2 - 4 GHz

Main index test curve

Gain vs. Frequency

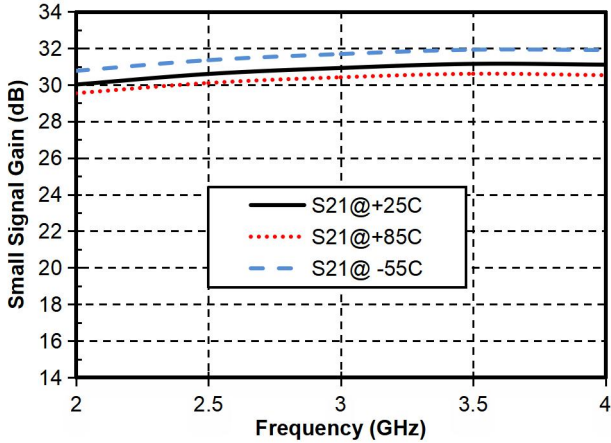

Noise Figure vs. Frequency

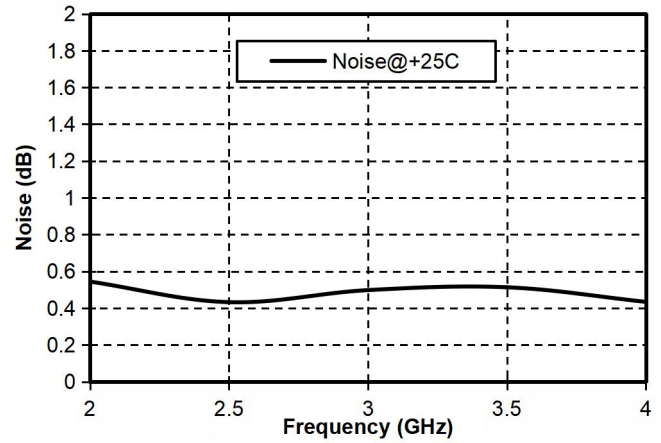

Input Return Loss vs. Frequency

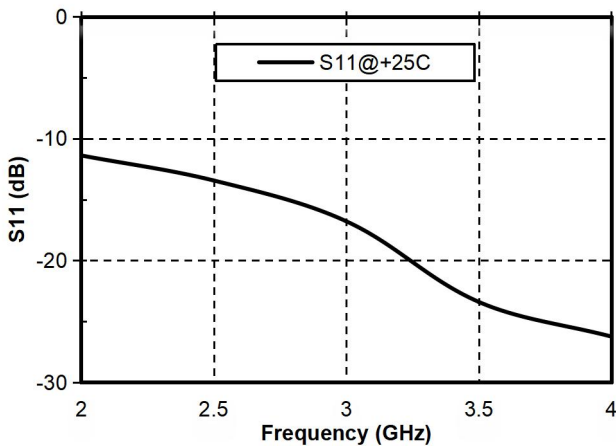

Output Return Loss vs. Frequency

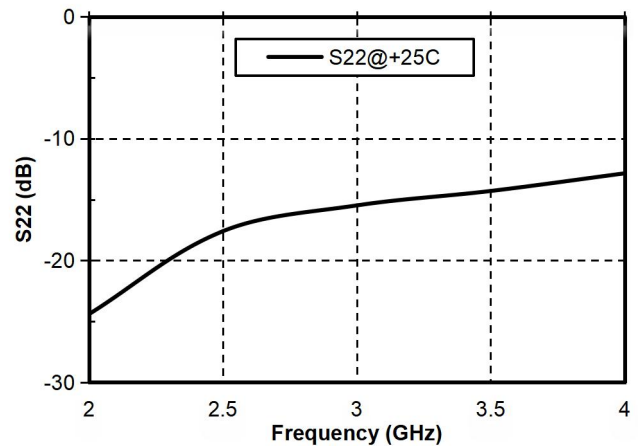

Reverse Isolation vs. Frequency

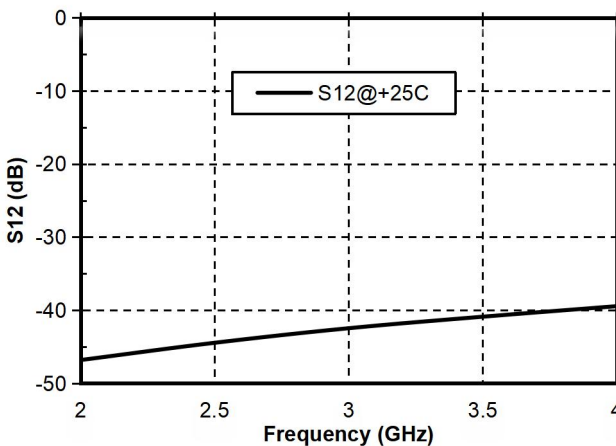

P-1dB vs. Frequency

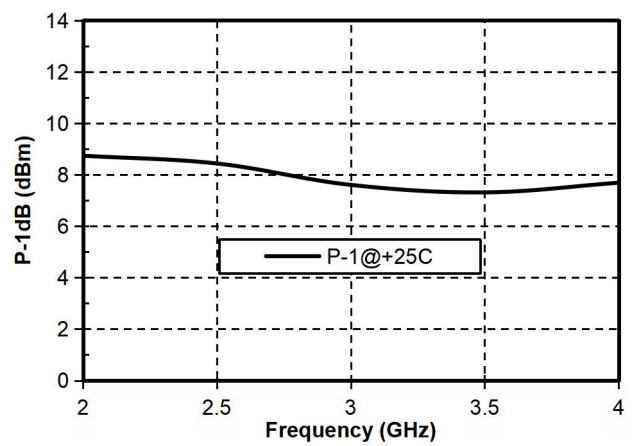

## GaAs MMIC Low Noise Amplifier Chip, 2 - 4 GHz

### Appearance structure

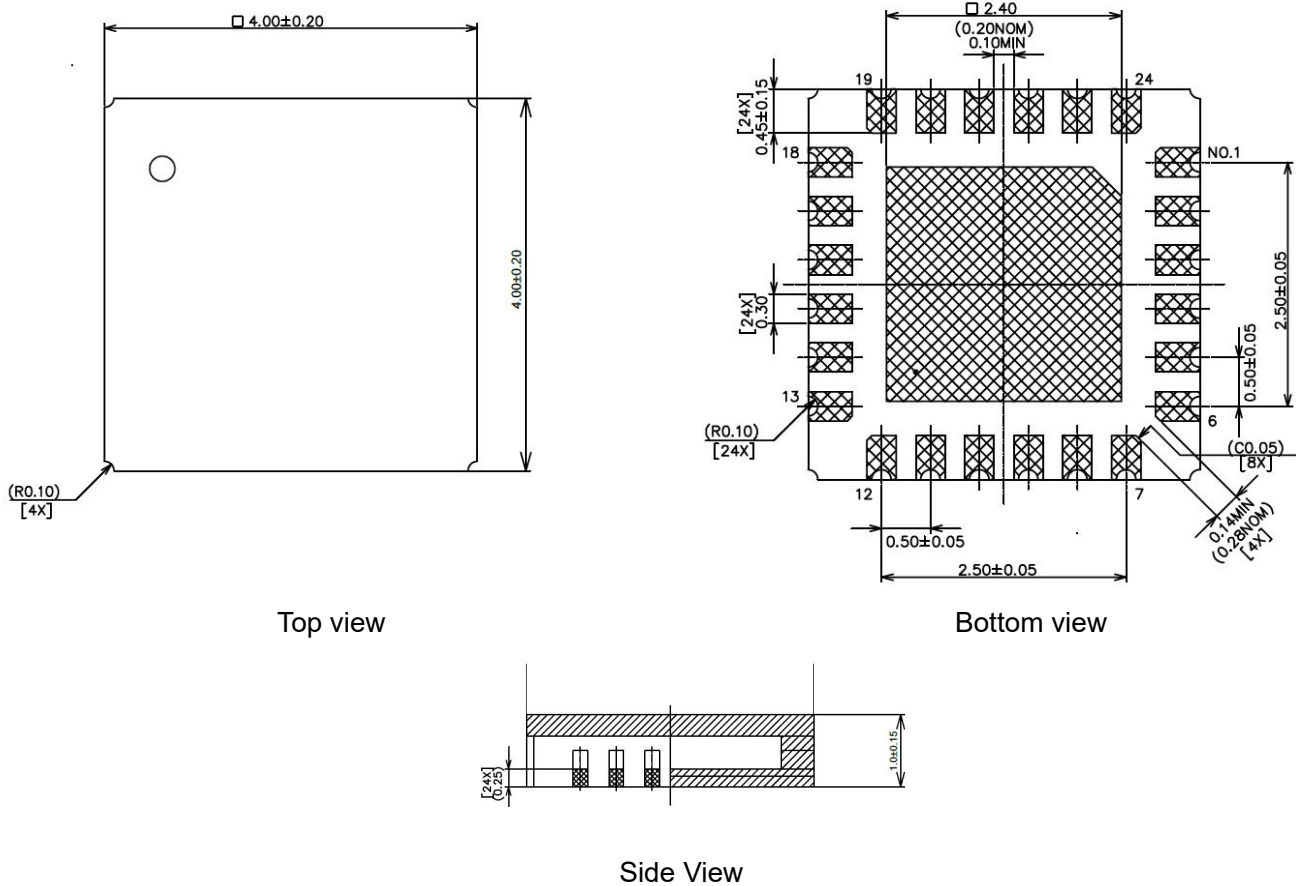

All units in the figures are millimeters .

Pin Definition		
Bonding point number	Function Symbol	Functional Description
3	RFIN	RF signal input terminal, no DC blocking capacitor required
16	RFOUT	RF signal output terminal, no DC blocking capacitor required
20	VDD	Amplifier Drain Bias
2, 4, 15, 17	GND	The bottom of the chip needs to be well grounded to RF and DC
1, 5~14, 18, 19, 21~24	NC	No welding required

## GaAs MMIC Low Noise Amplifier Chip, 2 - 4 GHz

### Recommended Circuit

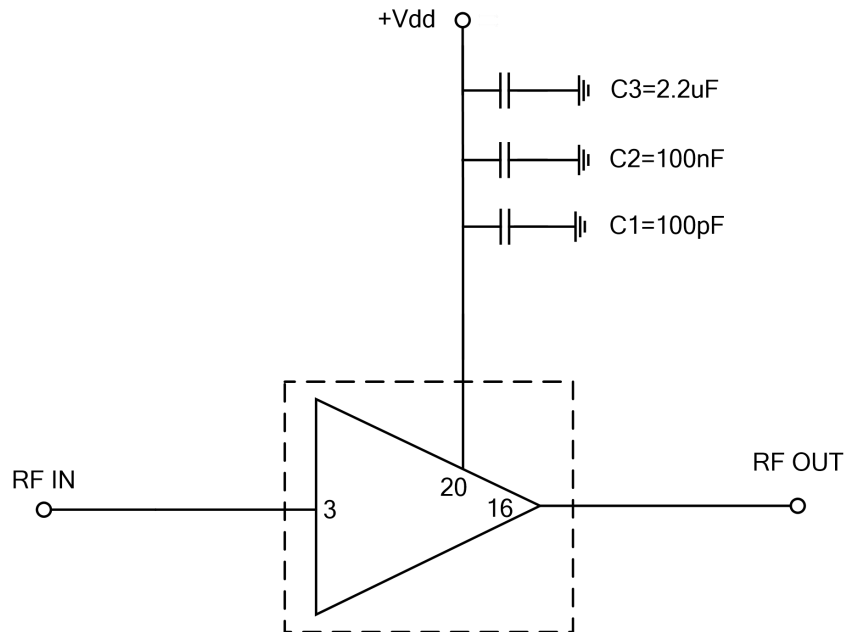

Raw material	Capacitance, inductance, resistance
C1	100pF
C 2	100nF
C 3	2.2uF

### Precautions for use

- Sealing material : Ceramic material that meets ROHS standards
- Lead frame material: copper alloy
- Lead surface plating: gold, gold layer thickness greater than 1.5um
- Maximum reflow peak temperature: 260 °C