

## GaAs MMIC Low Noise Amplifier Chip, 1-18 GHz

### Performance characteristics

- Frequency Range: 1 - 18 GHz
- Small Signal Gain: 14.5 dB
- Noise figure: 1.8dB typ. / 2.4dB max.
- P -1 dB: 16.5dBm
- Power supply: + 5V /35mA
- 50Ohm input / output
- 100% on-wafer testing
- Chip size: QFN 3X3

### Block Diagram

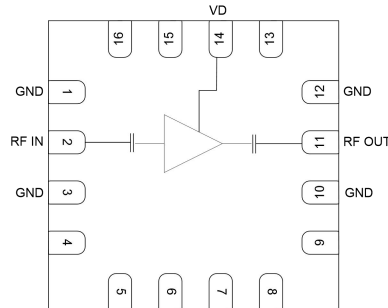

### Product Introduction

GLA-0118C-PQ3 is a broadband low noise amplifier chip with a frequency range of 1GHz~18GHz, a small signal gain of 14.5dB, and an in-band noise figure of 1.8 dB. GLA-0118C-PQ3 is powered by a single +5V power supply. This chip is packaged in a 3 x 3 mm plastic surface mount package, and the surface of the pin pad is gold-plated, which is suitable for reflow soldering installation.

### Use restriction parameter <sup>1</sup>

Maximum drain voltage	+7V
Maximum input power	+20dBm
Operating temperature	-55 ~ +85°C
storage temperature	-65 ~ +150°C

【1】 Exceeding any of these maximum limits may cause permanent damage.

### Electrical performance parameters ( TA = +25°C, Vd=+5V )

Index	Minimum	Typical Value	Maximum	Unit
Frequency Range	1-18			G Hz
Small Signal Gain	14	14.5	15.5	dB
Gain Flatness		± 0.75		dB
Noise Figure	-	1.8	2.4	dB
P -1 dB	14.5	16.5	18	dBm
Psat	18	18.5	19.5	dBm
Input return loss	9	12	-	dB
Output return loss	12	16	-	dB
Quiescent Current		35		mA

## GaAs MMIC Low Noise Amplifier Chip, 1-18 GHz

Main index test curve

Gain vs. Temperature

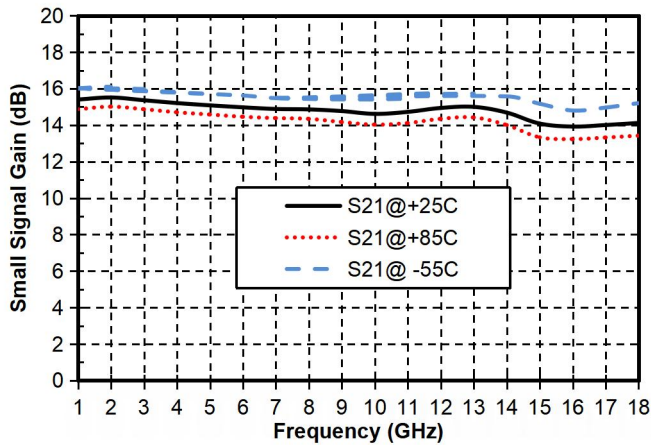

Noise Figure vs. Temperature

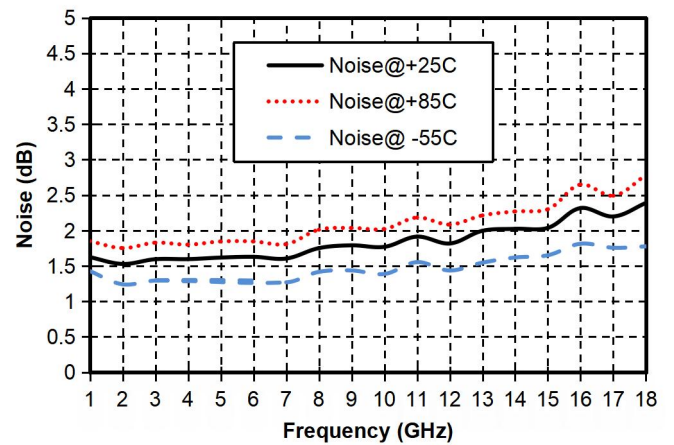

Input Return Loss vs. Frequency

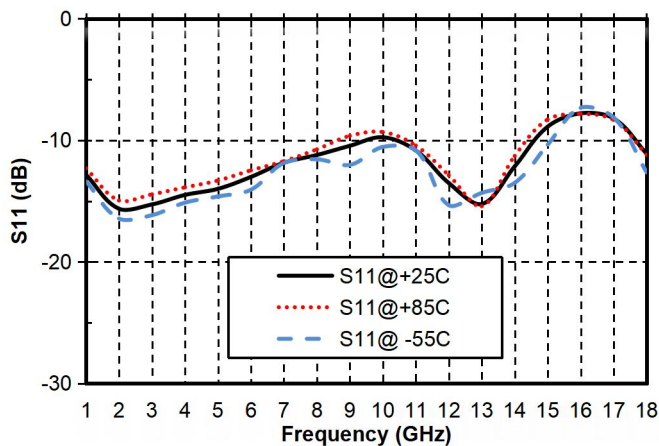

Output Return Loss vs. Frequency

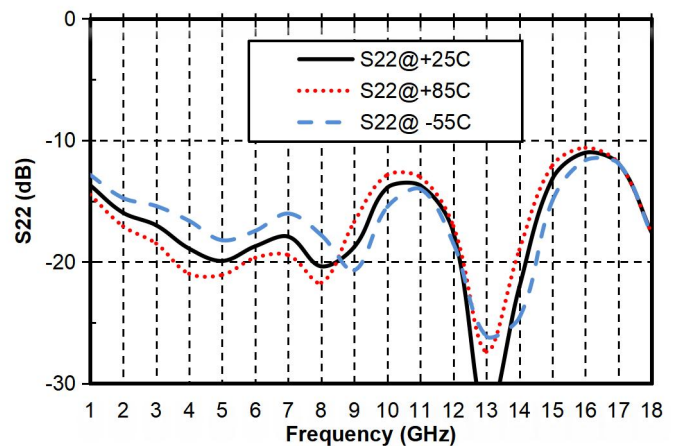

Reverse Isolation vs. Frequency

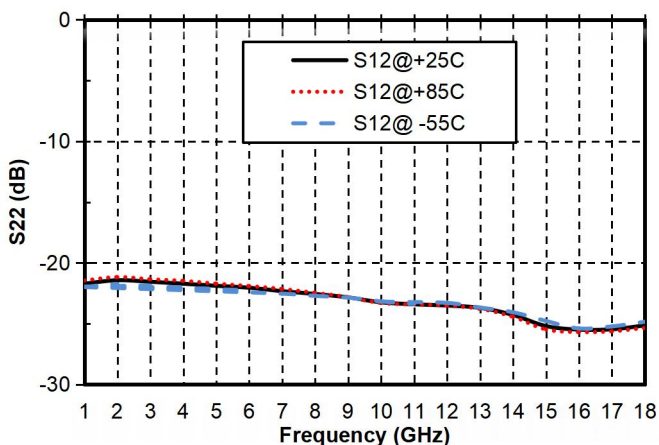

P-1dB vs. Frequency

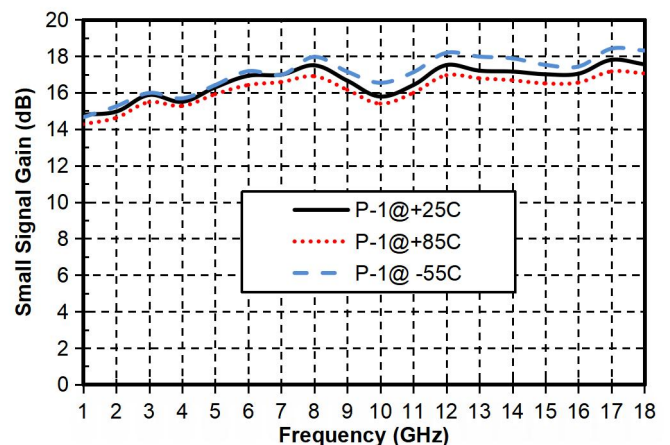

## GaAs MMIC Low Noise Amplifier Chip, 1-18 GHz

### Appearance structure

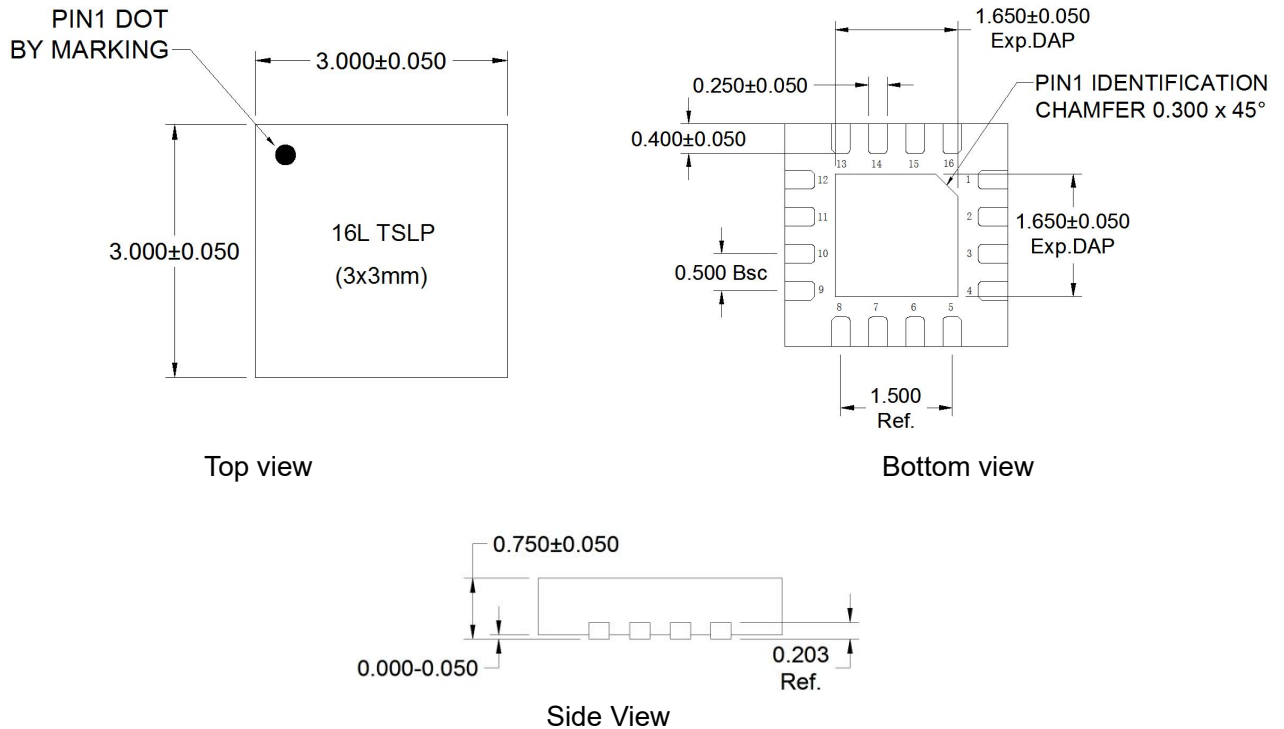

The units in the figure are all millimeters, with a tolerance of  $\pm 0.05$  mm.

Pin Definition		
Bonding point number	Function Symbol	Functional Description
2	RFIN	RF signal input terminal, no DC blocking capacitor required
11	RFOUT	RF signal output terminal, no DC blocking capacitor required
14	VDD	Amplifier Drain Bias
1, 3, 10, 12	GND	The bottom of the chip needs to be well grounded to RF and DC
4~9, 13, 15, 16	NC	No welding required

## GaAs MMIC Low Noise Amplifier Chip, 1-18 GHz

### Recommended Circuit

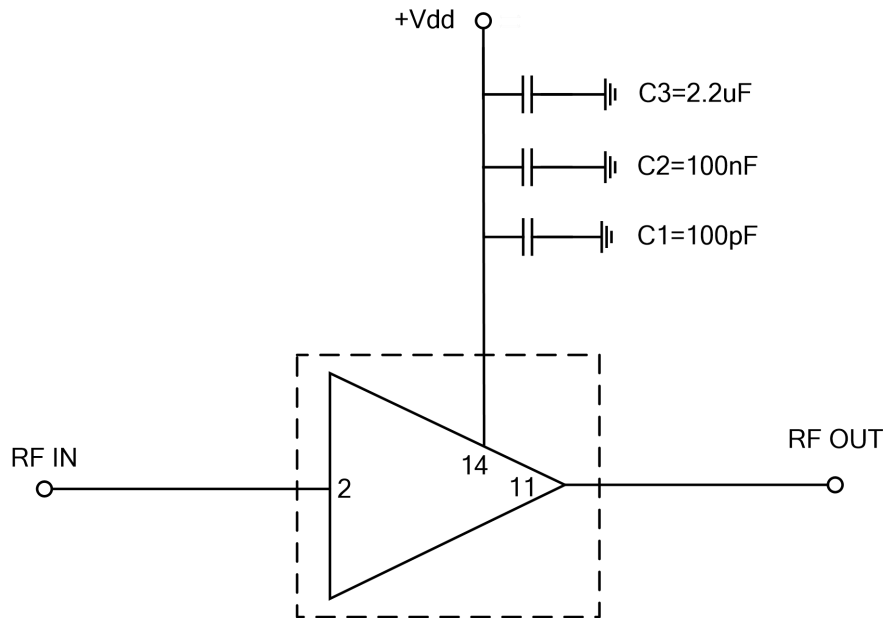

Raw material	Capacitance, inductance, resistance
C1	100pF
C2	100nF
C3	2.2uF

### Precautions for use

- Sealing material: Low-pressure injection molding plastic that meets ROHS specifications
- Lead frame material: copper alloy
- Lead surface plating: 100% matte tin
- Maximum reflow peak temperature: 260 °C