

## GaAs MMIC Low Noise Amplifier Chip, 0.38-1GHz

### Performance characteristics

- Frequency range: 0.38-1GHz
- Small signal gain: 35.5dB
- Gain flatness:  $\pm 0.75$ dB
- Noise figure: 0.5dB
- P-1dB: 14dBm
- Power supply: 5V/65mA
- Input/Output: 50Ohm
- 100% on-chip testing
- Chip size: 1.7 x 1.7 x 0.1 mm

### Product Introduction

GLA-003801A is a gallium arsenide single-chip amplifier operating at 0.38-1GHz. The noise figure of this amplifier is 0.5dB, and it can provide a gain of 35.5dB and a P-1dB output power of +14dBm. The chip adopts an on chip through-hole metalization process to ensure good grounding, without the need for additional grounding measures, making it simple and convenient to use. The back of the chip has undergone metalization treatment, suitable for eutectic sintering or conductive adhesive bonding processes.

#### Use restriction parameters<sup>1</sup>

Maximum leakage voltage	+8V
Maximum input power	+20dBm
Working temperature	-55 ~ +85°C
Storage temperature	-65 ~ +150°C

【1】 Exceeding any of the above maximum limits may result in permanent damage.

#### Electrical performance parameters( $T_A = +25^\circ\text{C}$ , $V_d = +5\text{V}$ )

Index	Minimum value	Typical value	Maximum value	Unit
Frequency range	0.38-1			GHz
Small signal gain	-	35.5	-	dB
Input return loss	-	$\pm 0.75$	-	
Output return Loss	-	16	-	dB
Reverse isolation	-	13	-	dB
Frequency range	-	43	-	dB
P-1dB	-	14	-	dBm
Psat	-	16	-	dBm
Noise figure	-	0.5	-	dB
Static current		65		mA

## GaAs MMIC Low Noise Amplifier Chip, 0.38-1GHz

Main indicator testing curve

Gain vs. Frequency range

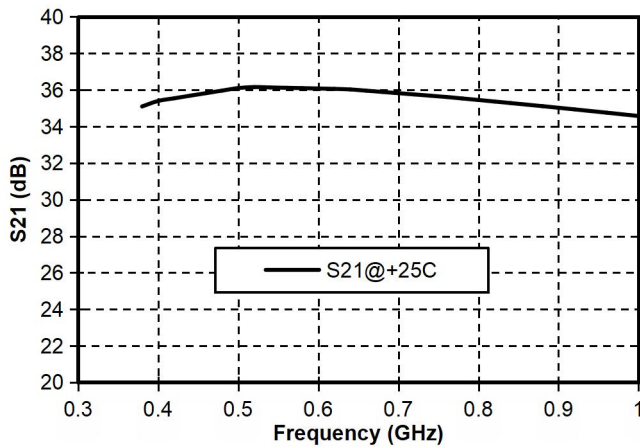

Noise Figure vs. Frequency

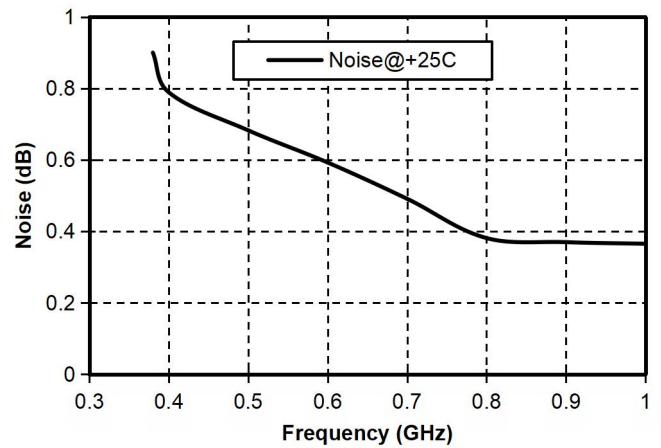

Input return loss vs. Frequency

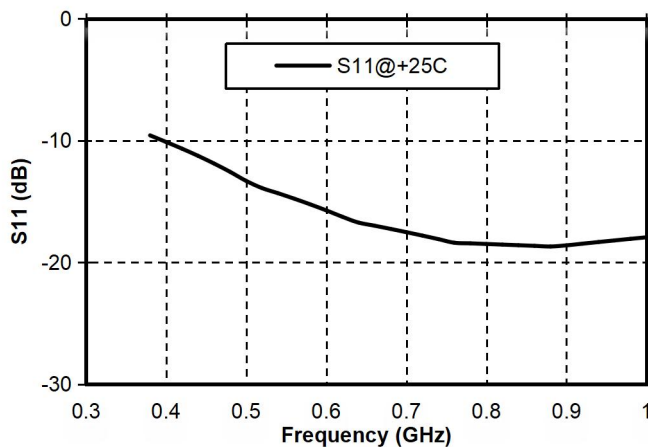

Output return Loss vs. Frequency

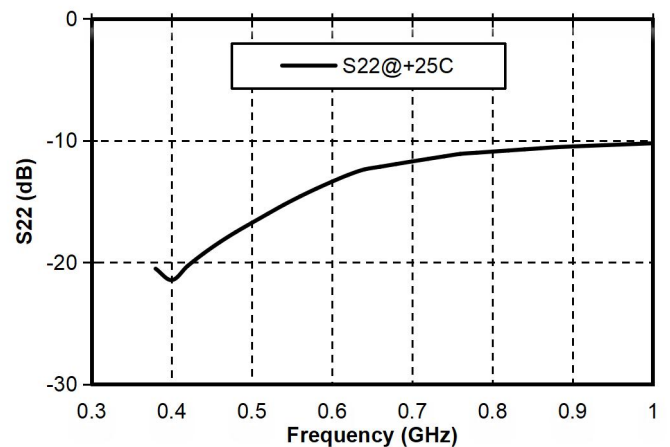

Reverse isolation vs. Frequency

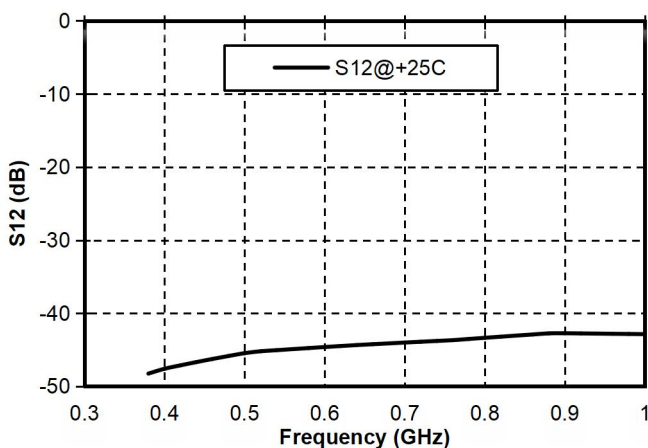

P-1dB/Psat vs. Frequency

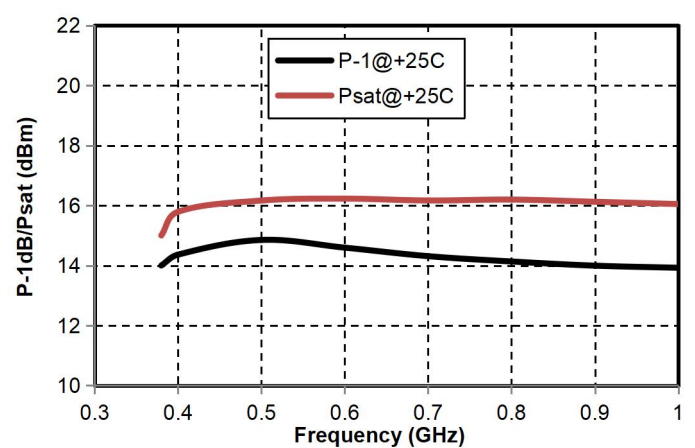

## GaAs MMIC Low Noise Amplifier Chip, 0.38-1GHz

### External structure<sup>2</sup>

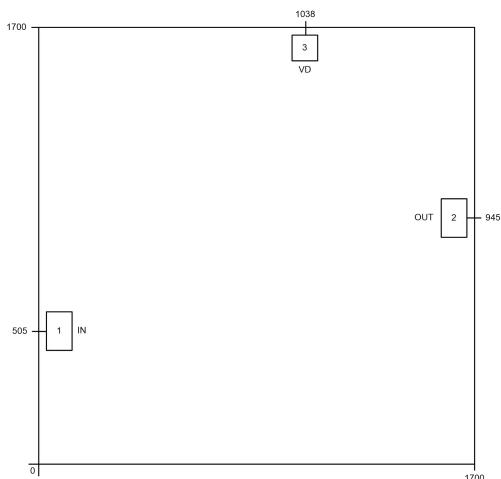

【2】 The units in the figure are all millimeters, with a tolerance of  $\pm 100\mu\text{m}$ .

### Recommended assembly diagram

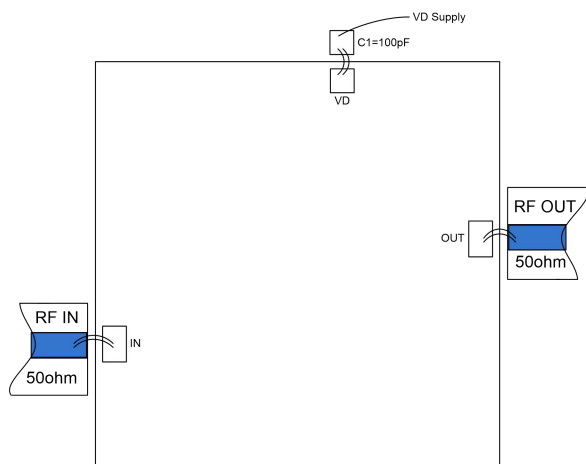

### Definition of bonding pressure point

Bond point number	Functional symbols	Function Description
1	RFIN	RF signal input terminal, no need for DC capacitors.
2	RFOUT	RF signal output terminal, no need for DC isolation capacitor.
3	VDD	Amplifier drain bias, requires an external 100pF bypass capacitor.
Chip bottom	GND	The bottom of the chip needs to be well grounded with RF and DC.