

GaAs MMIC Attenuator Chip,DC-6GHz

Performance characteristics

Frequency range: DC-6GHz
 Insertion loss: 1.2dB@6GHz
 Attenuation range: 31.5dB
 Bit count: 1
 Additional phase shift: 1.5°
 50Ohm input/output
 100% on-chip testing
 Chip size: 3 X 3mm

Functional Block Diagram

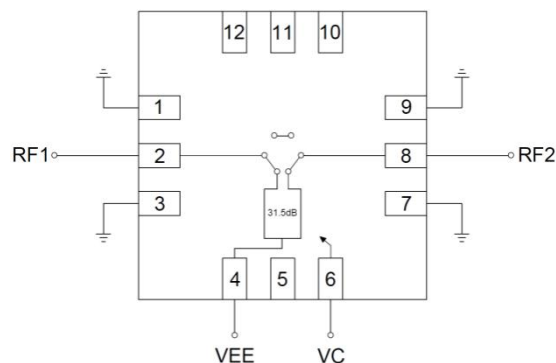

Product Introduction

GDA-0006-1D-PQ3 is a GaAs MMIC integrated parallel drive 6-bit CNC attenuator chip, with a frequency range of DC~6GHz and insertion loss of 1.2dB. GDA-0006-1D-PQ3 internal integrated driver with a switching speed of 40ns. The chip through-hole metallization process ensures good grounding, and the back is metallized, suitable for eutectic sintering or conductive adhesive bonding processes.

Usage restriction parameter ¹

Control voltage range	-0.5V~+5.5V
Power supply voltage	-6V
Maximum input power	+24dBm
Working temperature	-55 ~ +85°C
Storage temperature	-65 ~ +150°C

【1】 Exceeding any of the above maximum limits may result in permanent damage.

Electrical parameters(Ta=+25° C)

Index	Minimum	Typical value	Maximum value	Unit
Frequency range	DC~6			GHz
Insertion loss	-	-	1.2	dB
Attenuation range	31.5			dB
Attenuation number	1			bite
Attenuation accuracy (all frequency bands)	-2.6 ~ +1.2			dB
Phase fluctuation (full frequency band)	-0.1 ~1.5			degree
Input return loss	-	23	-	dB
Output Return Loss	-	25	-	dB

Switching speed	-	-	40	ns
P-1dB	-	23	-	dBm

GaAs MMIC Attenuator Chip, DC-6GHz

Main indicator testing curve

Insertion loss vs. frequency

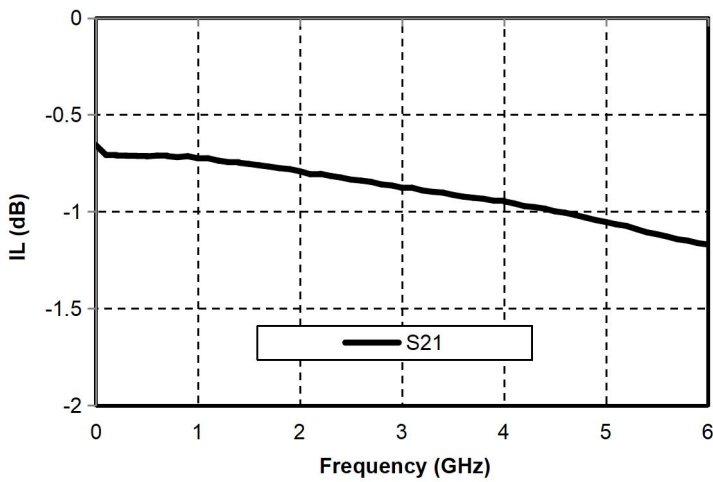

Attenuation vs. Frequency

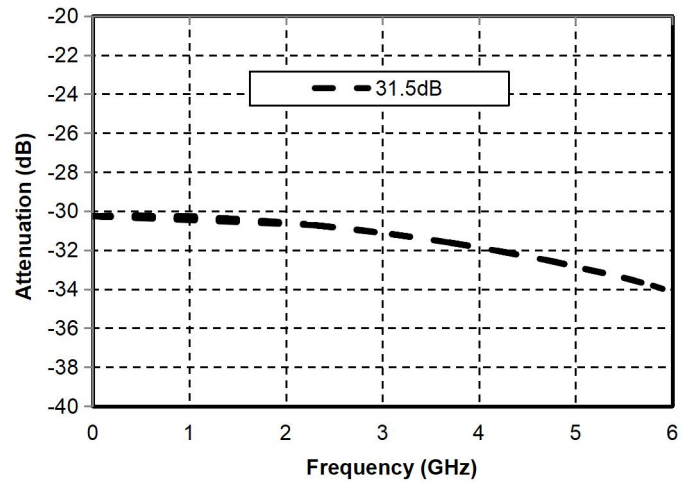

Input Echo vs. Frequency

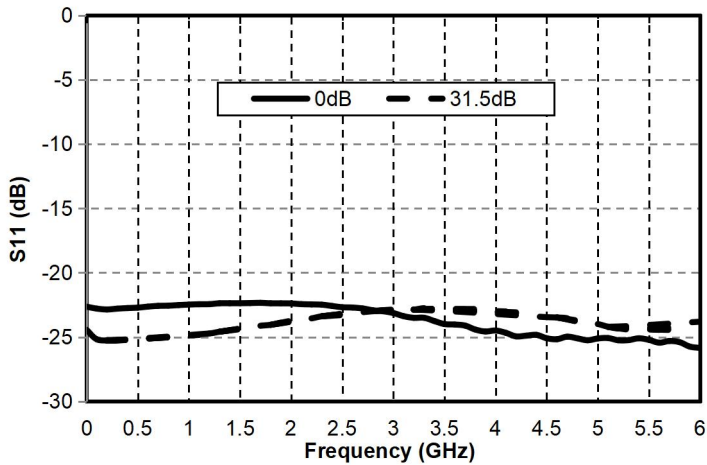

Output Echo vs. Frequency

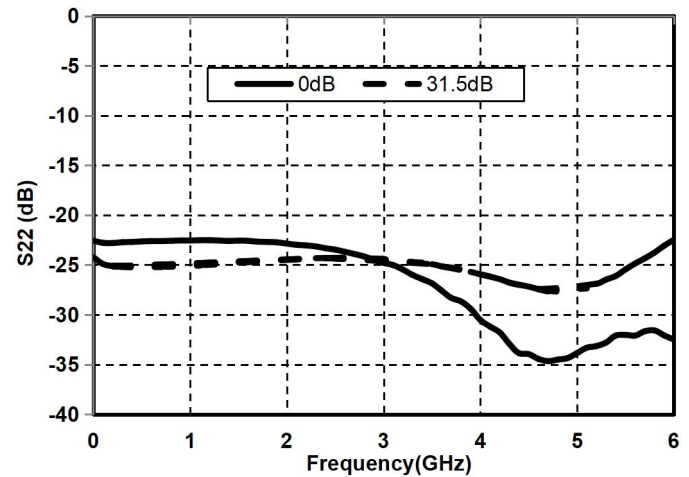

Attenuation additional phase shift vs. frequency

Attenuation accuracy vs. frequency

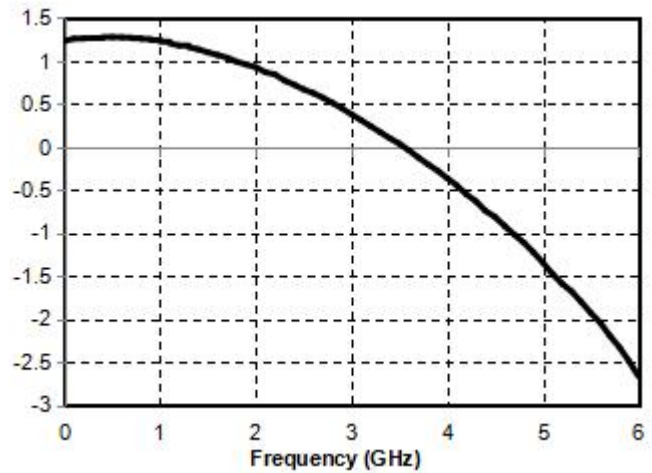
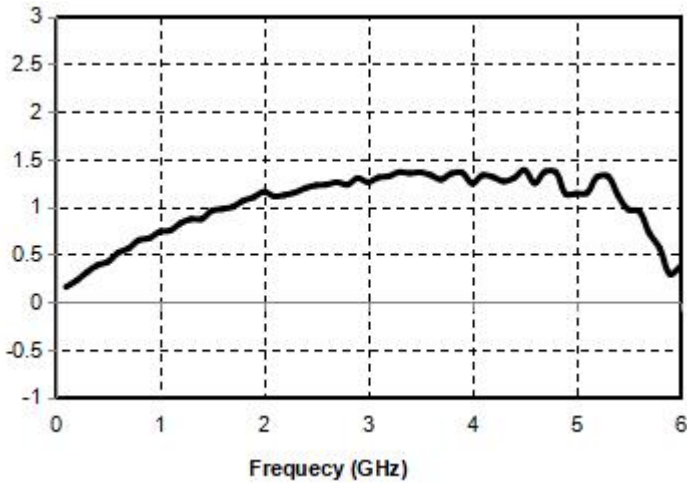

GaAs MMIC Attenuator Chip, DC-6GHz

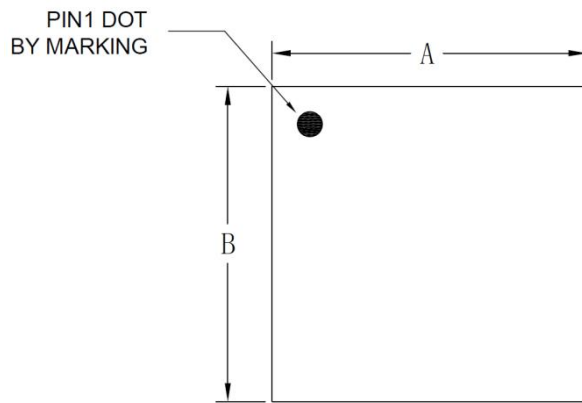

nal structure²

TOP VIEW

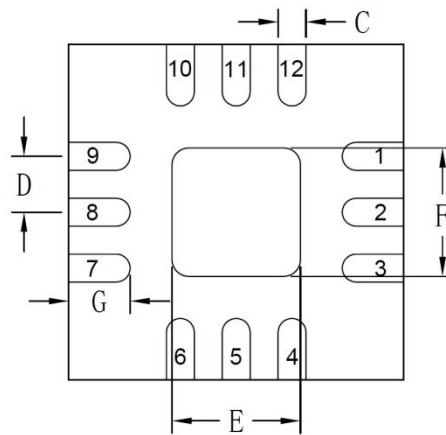

BOTTOM VIEW

标注	MIN	NOM	MAX
A	-	3.00 BSC	-
B	-	3.00 BSC	-
C	0.18	0.25	0.30
D	-	0.50	-
E	1.00	1.15	1.25
F	1.00	1.15	1.25
G	0.45	0.55	0.65

[2]The units in the figure are all millimeters.

Pad number	Functional symbols	Function Description
2	RF1	Connect a 50 ohm circuit externally to the signal input terminal; External 10nF DC isolation capacitor required
8	RF2	Connect a 50 ohm circuit externally to the signal output terminal;

		External 10nF DC isolation capacitor required
4	VEE	Bias voltage
6	VC	Control Port
1、3、7、9	GND	The bottom of the chip needs to be well grounded with RF and DC.

Truth table	
Attenuation state	VC
0dB	0V
31.5dB	5V

control voltage	
State	Bias condition
Low (0)	0 ~ 2.7V
High (1)	3.5~ 5V

Bias voltage and current		
VEE Range= -5Vdc±10%		
VEE (Vdc)	IEE (Typ.)(mA)	IEE (Max.)(mA)
-5V	1	1.3

Precautions for use

- Sealing material: Low pressure injection molding plastic that meets ROHS specifications
- Lead frame material: copper alloy
- Lead surface coating: 100% matte tin
- Maximum reflow soldering peak temperature: 260 °C