

GaAs MMIC6-bit CNC Attenuator Chip, 0.1-4GHz

Performance characteristics

Frequency range: 0.1-4GHz

Insertion loss: 2.0dB typ

Attenuation range: 0.5~31.5dB

Bit count: 6

Attenuation step: 0.5dB

Full positive: +5V power supply, 0/+5V control

(compatible with +3.3V)

50Ohm input/output

Chip size: QFN 4X4

Principle Block Diagram

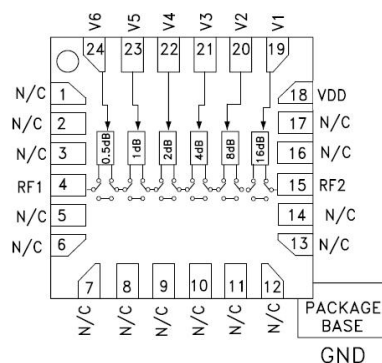

Product Introduction

GDA-0004-6W-PD-CQ4 is a GaAs MMIC 6-bit CNC attenuator chip, with a frequency range of 0.1-4GHz, insertion loss of 2.0dB, switching speed of 50ns, integrated driver inside the chip, using 0/+5V control (compatible with +3.3V). The amplifier adopts a 4X4mm surface mount lead-free ceramic casing, which can achieve airtight packaging. The surface of the pin pads is treated with gold plating technology, suitable for reflow soldering installation process.

Use restriction parameters

Power supply voltage range	+6V
Control voltage range	-0.5V~+5.5V
Maximum input power	+27dBm
working temperature	-55 ~ +85°C
Storage temperature	-65 ~ +150°C

Exceeding any of the above maximum limits may result in permanent damage.

Electrical parameters (Ta=+25 °C, VDD=+5V, 0/+5V control)

Index	minimum value	Typical value	Maximum value	Unit
Frequency range		0.1-4		GHz
Insertion loss	-	2.0	-	dB
Attenuation range		0.5~31.5		dB
Attenuation step		0.5		dB
Attenuation number		6		bite
Attenuation accuracy (fundamental state)	-	-	±1.0	dB
Additional phase shift (fundamental state)	-	-	±12	degree
Input/output wave loss	-	23/23	-	dB

Switching speed	-	50	-	ns
P-1dB	-	22	-	dBm
supply voltage	-	5	-	V
Power supply current	-	8	-	mA
Control high voltage	3.0	3.3	5	V
Control low voltage	0	-	0.8	V
Control current	-	-	1	mA

GaAs MMIC 6-bit CNC Attenuator Chip, 0.1-4GHz

Main indicator testing curve

Insertion loss vs. frequency

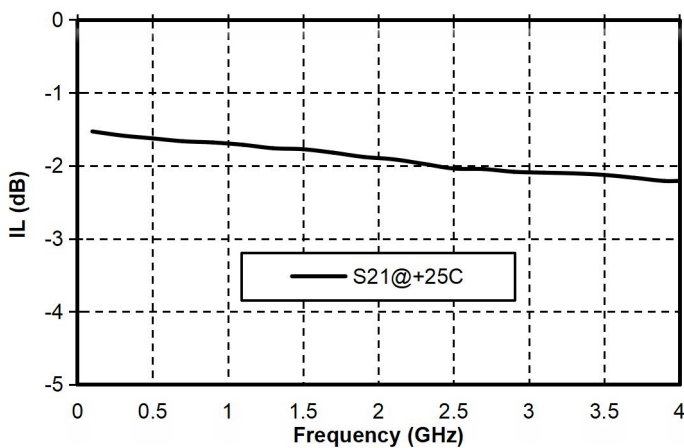

Reference attenuation state vs. frequency

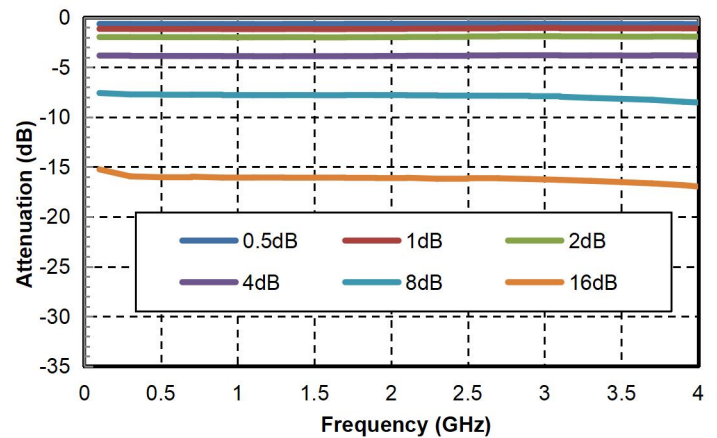

Input Echo vs. Frequency

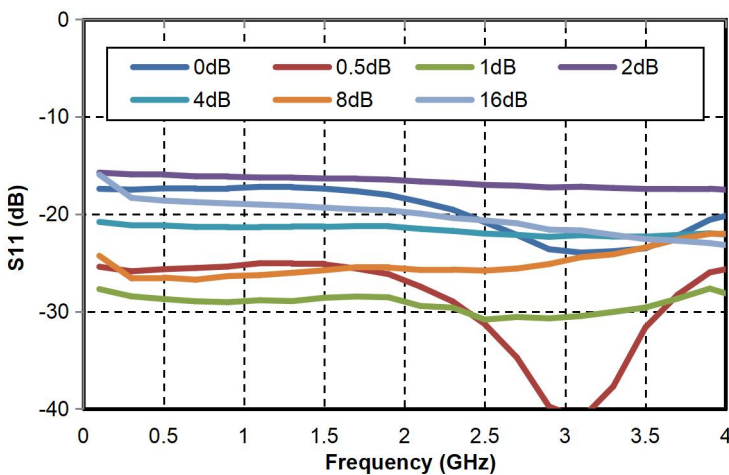

Output Echo vs. Frequency

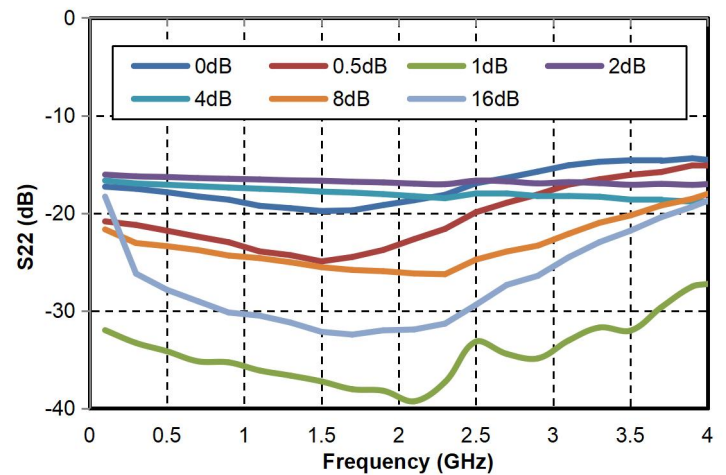

Attenuation accuracy (fundamental state) vs. frequency

Additional phase shift (fundamental state) vs. frequency

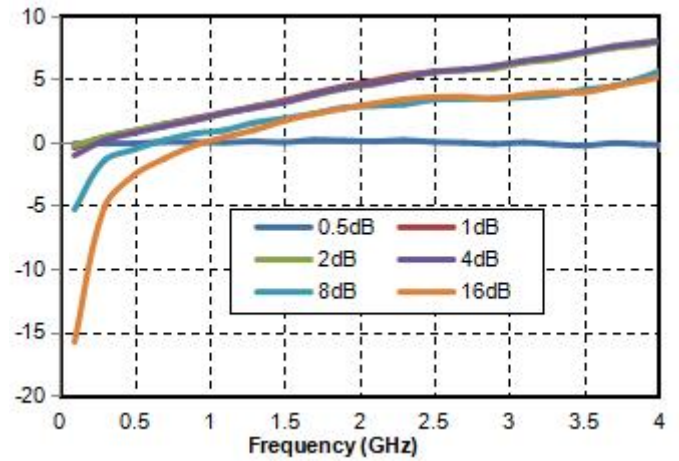
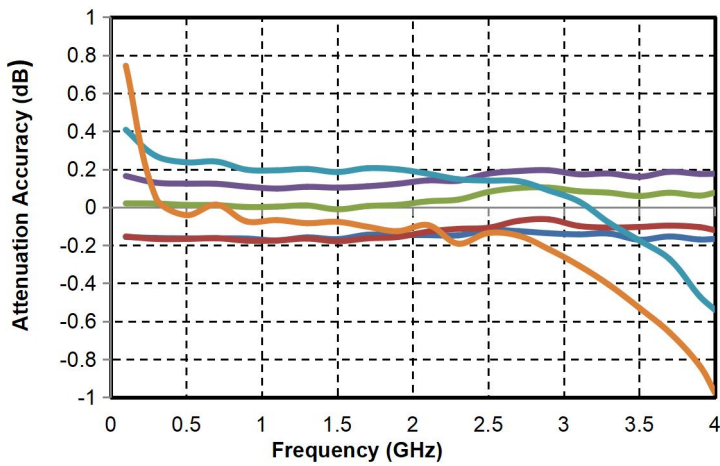

GaAs MMIC 6-bit CNC Attenuator Chip, 0.1-4GHz

External structure

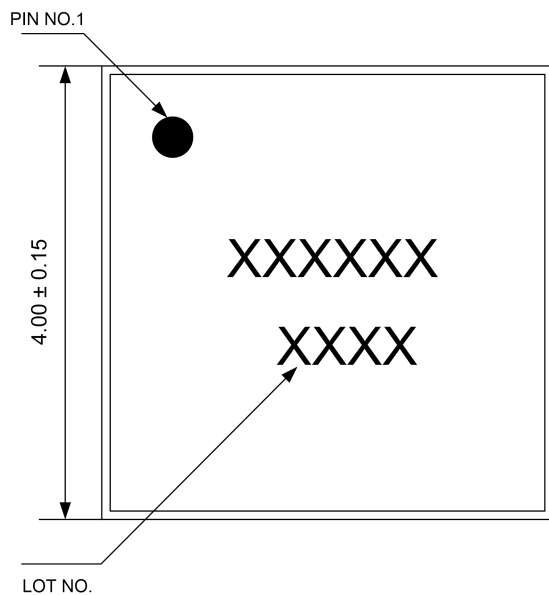

vertical view

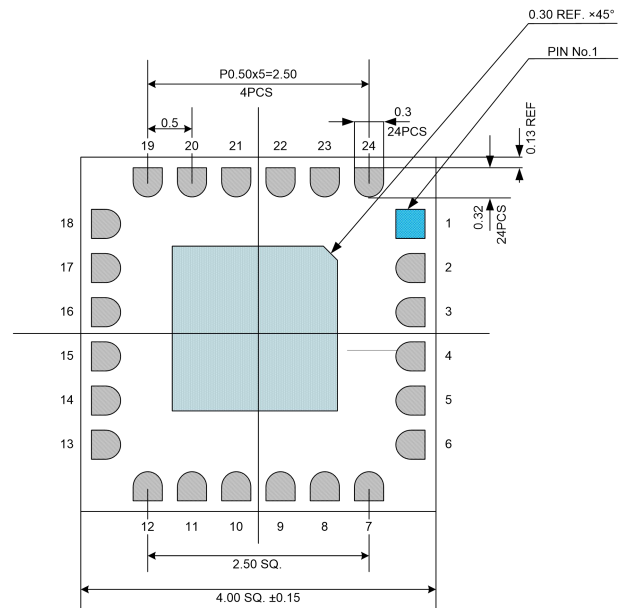

Top view

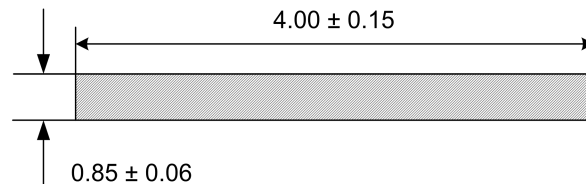

Side view

The units in the figure are all millimeters, with an unspecified tolerance of ± 0.15 mm

Truth table

Truth table							
V1	V2	V3	V4	V5	V6	VDD	Conduction pathway
+5V	+5V	+5V	+5V	+5V	+5V	+5V	Initial state N=0: attenuation amount is 0
+5V	+5V	+5V	+5V	+5V	0V		Attenuation state N=1: Attenuation amount is 0.5
+5V	+5V	+5V	+5V	0V	+5V		Attenuation state N=2: Attenuation amount is 1
+5V	+5V	+5V	0V	+5V	+5V		Attenuation state N=4: Attenuation amount is 2
+5V	+5V	0V	+5V	+5V	+5V		Attenuation state N=8: Attenuation amount is 4
+5V	0	+5V	+5V	+5V	+5V		Attenuation state N=16: Attenuation amount is 8
0V	+5V	+5V	+5V	+5V	+5V		Attenuation state N=32: Attenuation amount is 16
0V	0V	0V	0V	0V	0V		Attenuation state N=63: attenuation amount is 31.5

GaAs MMIC 6-bit CNC Attenuator Chip, 0.1-4GHz

Solder joint serial number	Functional symbols	Function Description
4	RFIN	The RF signal input terminal is externally connected to a 50 ohm circuit, and there is no integrated DC isolation capacitor inside the chip
15	RFOUT	The RF signal output terminal is externally connected to a 50 ohm circuit, and there is no integrated DC isolation capacitor inside the chip
18	VDD	Power on port, requires an external 100pF capacitor
19、20、21、22、23、24	VC	Attenuation control pads, see truth table for attenuation control details
Chip bottom	GND	The bottom of the chip needs to be well grounded with RF and DC
other	NC	No welding required

Recommended circuit

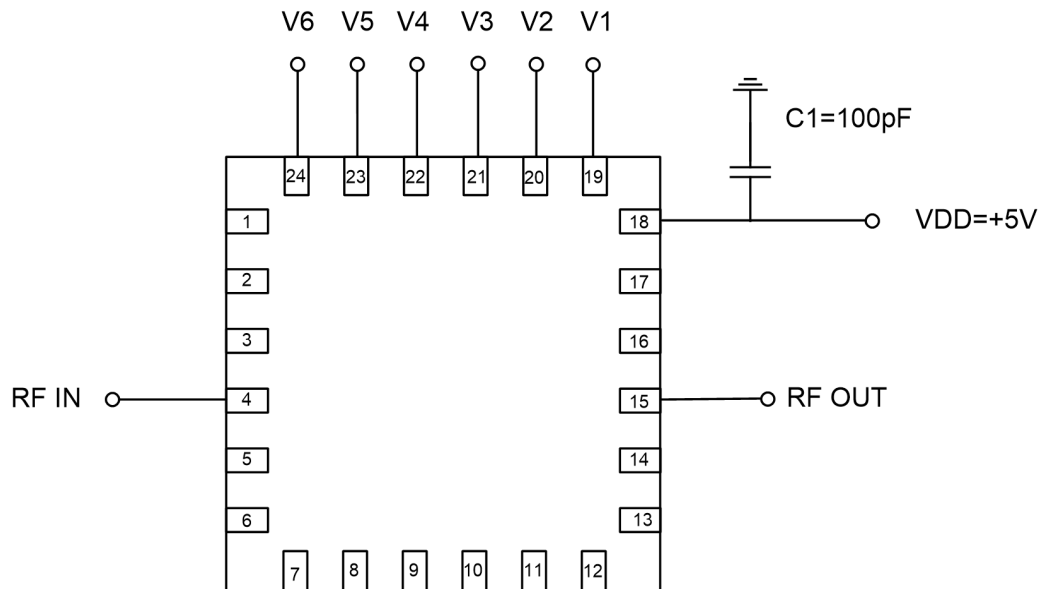

Precautions for use

- Sealing material: Ceramic material that meets ROHS specifications
- Lead frame material: copper alloy
- Lead surface coating: gold, with a gold layer thickness greater than 0.3um MIN
- Maximum reflow soldering peak temperature: 260 °C